



FAO/Netherlands Conference on

water for food
and ecosystems

**make it
happen**



The Hague
The Netherlands
31 January –
5 February 2005



FAO/Netherlands Conference on

water for food
and ecosystems

*make it
happen*

January 31 – February 5, 2005

The Netherlands Congress Centre (NCC)
The Hague The Netherlands

Contents

Programme	6
Objectives and working methodology of the Conference and Working Groups	13
Floor plan	16
Index (floor plan)	20

Conference Premises

The Netherlands Congress Centre

Churchillplein 10 • 2517 JW Den Haag

Tel: +31 (0)70-3066366

Fax: +31 (0)70-3066443

Programme

Sunday 30 January 2005

15.00 – 18.00 hrs Registration at the Congress Centre

Monday 31 January 2005

08.00 – 09.15 Registration at the Congress Centre

Plenary session (Prins Willem Alexander Hall)

09.30 – 09.40 Opening statement of the Minister of Agriculture, Nature and Food Quality of The Netherlands, Dr. Cees Veerman; Chair of the Conference

09.40 - 10.45 Keynote Addresses

- HRH Prince of Orange of The Netherlands
- Director General of the Food and Agriculture Organization (FAO), Mr. Jacques Diouf
- Minister of State for Natural Resources of Ethiopia, Dr. Tekalign Mamo

10.45 – 11.00 Break

11.00 – 12.45 Introduction to the themes
Integrating Water for Food and Ecosystems
by Prof. Dr. Ir. R. Rabbinge on behalf of the
InterAcademy Council

Theme 1: Implementation, Know-How for Action
Ms. B.P. Sonjica, Minister of Water Affairs and Forestry of the Republic of South Africa

Theme 2: The 'New Economy' of Water for Food And Ecosystems
Mr. Turner, University of East Anglia, UK

Theme 3: Enabling environment
Ms. Catley-Carlson, Chair of the Global Water Partnership

12.45 – 13.00 Objectives and working methodology of the Conference and working groups by Chair of the Conference

13.00 – 14.30 Lunch break

Working Groups (Prins Willem Alexander Hall, Van Gogh Hall and Rembrandt Hall)

14.30 – 18.00 Working Groups
Working Group 1 on Theme 1
Case Inner Niger Delta, Mali
Working Group 2 on Theme 2
Case Andalusia, Spain
Working Group 3 on Theme 3
Case Chilika Lagoon, India

18.00 – 19.30 Reception hosted by FAO in de Mondriaan Foyer of the Congress Centre

Tuesday 1 February 2005

Working Groups (Prins Willem Alexander Hall, Van Gogh Hall and Rembrandt Hall)

09.00 – 11.00

Working Groups

Working Group 1 on Theme 1

Case Local Waterboards, The Netherlands

Working Group 2 on Theme 2

Case Rainwater harvesting, South Africa

Working Group 3 on Theme 3

Case EU Water Directive, Poland

11.00 – 11.15

Break

Plenary session (Prins Willem Alexander Hall)

11.15 – 12.30

Plenary presentations of Working Group

Results and discussions; moderator

Dr. P. Bridgewater, Secretary General, Ramsar

Convention on Wetlands

12.30 – 14.00

Lunch break

Working Groups (Prins Willem Alexander Hall, Van Gogh Hall and Rembrandt Hall)

14.00 – 16.00

Working Groups

Working Group 1 on Theme 1

Case Pantanal, Brazil

Working Group 2 on Theme 2

Case Rice / Fish systems, Laos Sri Lanka

Working Group 3 on Theme 3

Case Pangani, Tanzania

16.00 – 16.15	Break
16.15 – 18.15	<p>Working Groups</p> <p>Working Group 1 on Theme 1 <i>Case LEAD / Livestock, China</i></p> <p>Working Group 2 on Theme 2 <i>Case Environmental payments, Ecuador</i></p> <p>Working Group 3 on Theme 3 <i>Case Tarcoles, Costa Rica</i></p>

Wednesday 2 February 2005

Plenary session (Prins Willem Alexander Hall)

09.00 – 11.00	Plenary presentations of Working Groups and discussions; moderator Dr. H. Zedan, Executive Secretary, Convention on Biological Diversity
11.00 – 11.15	Break
11.15 – 12.00	E-Forum results and other presentations/activities
12.30 – 17.30	Excursions
18.45	Departure coaches from Congress Centre
19.00 - 21.00	Reception and dinner/buffet hosted by the Government of The Netherlands in the Hall of Knights ('Ridderzaal'), Parliament Building, 11 Binnenhof, The Hague

Thursday 3 February 2005

Working Groups (Prins Willem Alexander Hall, Van Gogh Hall and Rembrandt Hall)

09.00 – 11.00	Working Groups Draft conclusions and recommendations for themes, 1, 2 and 3
11.00 – 11.15	Break
11.15 – 13.00	Continuation Working Groups Draft conclusions and recommendations.
13.00 – 14.30	Lunch break

Plenary session (Prins Willem Alexander Hall)

14.30 – 15.30	Plenary presentation of Working Groups and discussion
15.30 – 15.45	Break
15.45 – 18.00	General conclusions, recommendations and agreed actions on the themes

Parallel to the plenary session (Mondriaan Hall)

14.30 – 18.00	Ministerial Round Table
19.00 – 22.00	Dinner ministers, Pavilion 'de Witte' hosted by Minister Cees Veerman 4 Pellenaerstraat, The Hague

Friday 4 February 2005

Plenary session (Prins Willem Alexander Hall)

09.00- 10.45	Multi-stakeholder dialogue (Civil society, NGO's, private sector)
10.45 – 11.00	Break
11.00 – 11.30	Report of the Ministerial Round Table by chair HRH The Prince of Orange of The Netherlands
11.30 – 13.00	Adoption of the report of the conference
13.00 – 13.30	Closing session <ul style="list-style-type: none">• Statement on behalf of FAO by dr. Louise O. Fresco, Assistant Director General• Statement on behalf of The Netherlands by dr. Cees Veerman, Minister of Agriculture, Nature and Food Quality
13.30 – 15.00	Lunch break / End of conference

Objectives and working methodology of the Conference and Working Groups

The objectives are:

- Identify best practices and lessons learned aimed at the implementation of existing international commitments on sustainable water use in relation to food and ecosystems
- Formulate recommendations based on real field experiences with balancing water for food and ecosystems giving due attention to the mutual interdependency

Working methodology of the Conference

To set the scene, *three keynote speakers* will introduce the three themes of the conference:

- 1 Fostering Implementation: Know-how for Action;
- 2 A 'New Economy' for Water for Food and Ecosystems; and
- 3 The Enabling Environment.

These introductions and related questions will give guidance to our work in the working groups, while analysing the selected cases.

Centrepiece of the conference is the discussion of twelve practical cases. These cases, coming from all over the world, will be discussed in *three working groups*. Each working group will focus on one of the themes and discuss a total of 4 cases in four times two-hour sessions.

The purpose of the working group sessions is to identify lessons for *actions* that reconcile water for food and ecosystems, along with the *conditions* that are required for successful implementation of these actions. The presented cases in the working group sessions are used as a starting point for discussion. The recommendations should be at a more generic level, taking into account also your own insights. In short, your contributions are needed to translate the specific to the generic.

Plenary sessions will enable feedback of the working groups to all participants. The plenary will give the opportunity to hear about discussions & outcomes of all the cases and to get a broader view of all the three themes.

During the *adoption of the report*, on Friday morning, the conclusions and recommendations for all three themes will be presented and reviewed. As this will represent the lessons learnt and the message from the participants, all experiences should be in here, even if it represents the lesson of a small number of participants. We do not intend to negotiate the text of the report. In our view, the report should give a clear message to the international community and will cover the broad range of experiences and views of the participants.

A *Ministerial Round Table* will be organised on Thursday afternoon to reflect on the outcomes of the working groups. The results of the MRT will be reported to the plenary on Friday morning.

General arrangements for discussions in working groups

Each working group has two co-chairs, a rapporteur and two working group assistants.

- The co-chairs are responsible for facilitating discussions; time management; and ensuring that all participants are able to contribute to the discussion.
- The rapporteur is responsible for reporting the findings of the working group back to the plenary sessions.
- Each working group is assigned two assistants from the FAO-Netherlands Secretariat, to assist the co-chairs and rapporteur when needed.

What is expected from conference participants?

- Share knowledge and experiences on practical tools and real-life practices and policies for balancing water allocation for food and ecosystems: What is working well? What is promising? What are the obstacles? What needs to be done to remove them and ensure progress?
- Openness and willingness to discuss with other participants. The focus of the Conference is twofold: sending a clear message to the international community on how to deliver the already existing commitments, and bringing fruitful lessons learnt 'back home'.

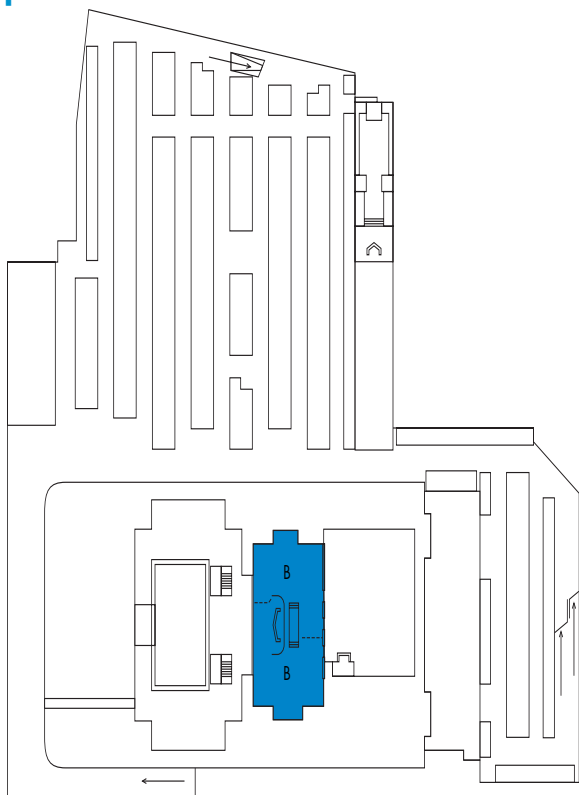

B Restaurant

GROUND FLOOR

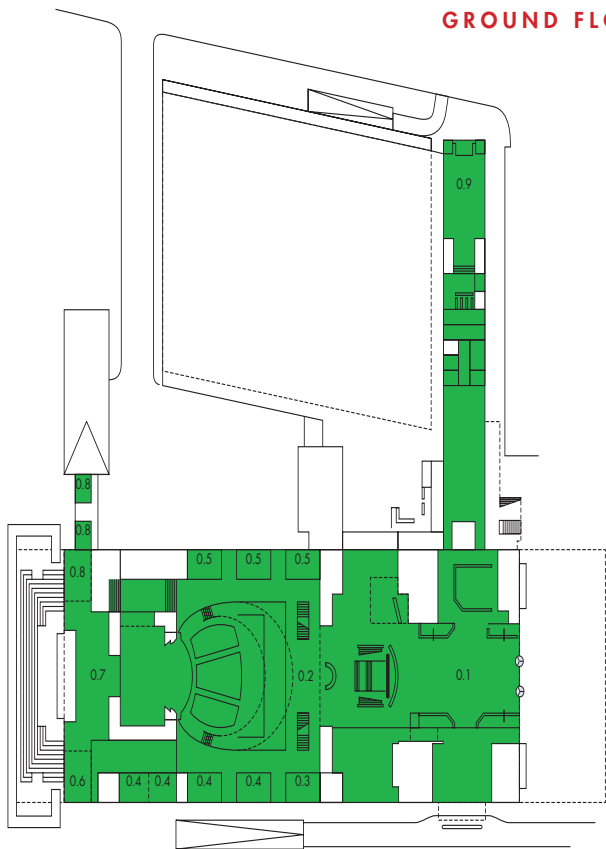

- | | | | |
|-----|------------------------------|-----|--------------------|
| 0.1 | Main Hall Ground Floor | 0.6 | Vermeer room 1 |
| 0.2 | Foyer Prins Willem Alexander | 0.7 | Vermeer Lounge |
| 0.3 | Interpreters room | 0.8 | Vermeer room 2 |
| 0.4 | Breughel rooms | 0.9 | Carel Willink Hall |
| 0.5 | Breitner rooms | | |

FIRST FLOOR

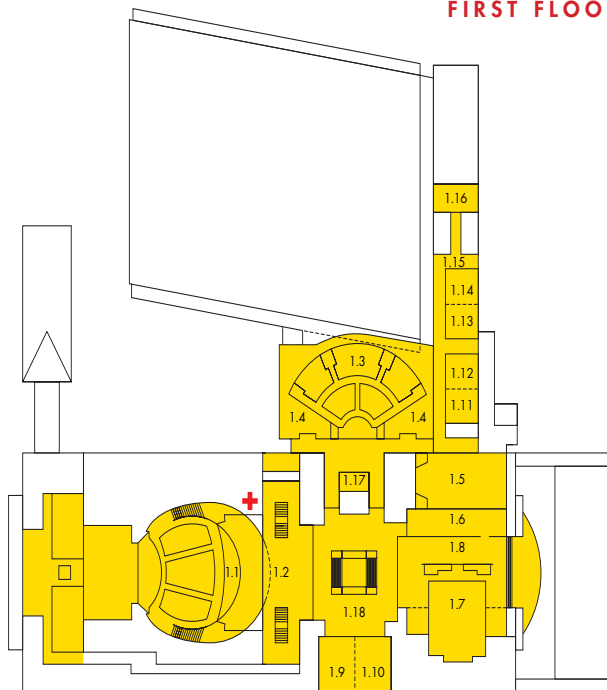

- | | | | |
|-----|-----------------------------------|------|-----------------------|
| 1.1 | Prins Willem Alexander Hall | 1.10 | Escher Hall 2 |
| 1.2 | Foyer Prins Willem Alexander Hall | 1.11 | Mesdag Hall 1 |
| 1.3 | Van Gogh Hall | 1.12 | Mesdag Hall 2 |
| 1.4 | Foyer Van Gogh Hall | 1.13 | Maris Hall 1 |
| 1.5 | Rembrandt Hall | 1.14 | Maris Hall 2 |
| 1.6 | Foyer Rembrandt Hall | 1.15 | Meditation room |
| 1.7 | Mondriaan Hall | 1.16 | Frans Hals Hall |
| 1.8 | Foyer Mondriaan Hall | 1.17 | Zonnebloemen |
| 1.9 | Escher Hall 1 | 1.18 | Main Hall First Floor |
| | | + | First Aid |

SECOND FLOOR

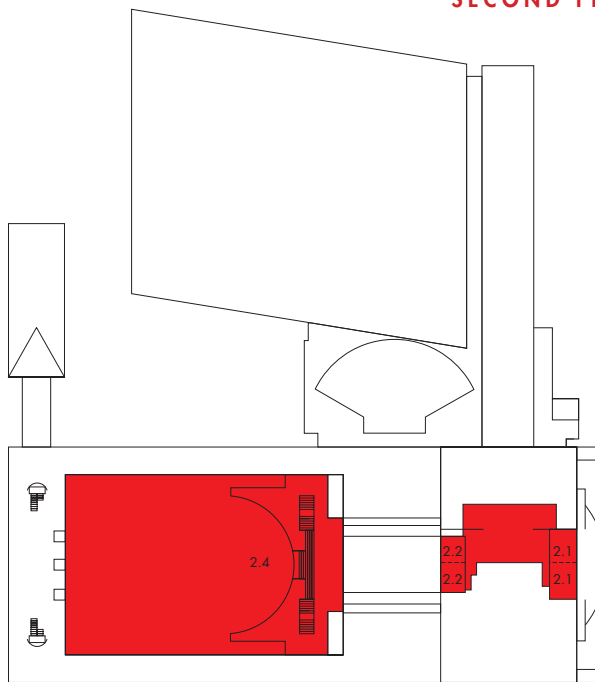

- 2.1 Van Ruysdael Hall 1/2
- 2.2 Van Ruysdael Hall 3/4
- 2.3 Foyer Van Ruysdael
- 2.4 Balcony Prins Willem Alexander Hall

INDEX

Bank	Main Hall Ground Floor	0.1
Business Centre	Main Hall Ground Floor (info desk)	0.1
Cloak Room	Main Hall Ground Floor	0.1
Conference Bags	Main Hall Ground Floor	0.1
Cyber Café	Foyer Rembrandt Hall	1.6
Delegate Lounge	Foyer Van Gogh Hall	1.4
Document Distribution (pigeon holes)/Main Hall	Ground Floor	0.1
DSA / bank	Main Hall Ground Floor	0.1
First Aid/Medical Room	Foyer Prins Willem Alexander	 1.2
Information desk	Main Hall Ground Floor	0.1
Information stands	Main Hall First Floor	1.18
Lost and Found	Main Hall Ground Floor (info desk)	0.1
Meditation Room	Meditation Room	1.15
Press Working Area	Van Ruysdael Hall 3/4	2.2
Press Conference Hall	Van Ruysdael Hall 1/2	2.1
Registration Counter	Main Hall Ground Floor	0.1
Restaurant	Foyer Jan Steen Hall/Paulus Potter Hall	basement B
Speakers room	Zonnebloemen	1.17
Travel desk	Main Hall Ground Floor	0.1

MEETING ROOMS

Plenary meeting	Prins Willem Alexander Hall	1.1
Ministerial Round Table		
Meeting	Mondriaan Hall	1.7
Working Group 1	Prins Willem Alexander Hall	1.1

Working Group 2	Van Gogh Hall	1.3
Working Group 3	Rembrandt Hall	1.5

REGIONAL GROUPS

African Group	Van Gogh Hall	1.3
G77/China	Van Gogh Hall	1.3
Asian	Escher Hall 1	1.9
Central / Eastern Europe	Escher Hall 2	1.10
GRULAC	Carel Willink Hall	0.9
JUSCANZ	Mesdag Hall 1	1.11
WEOG/EU	Rembrandt Hall	1.5

OFFICES

FAO	Ground Floor	0.4/0.6
The Netherlands	Ground Floor	0.8
Chairs Working Groups	Ground Floor	0.5
E-Conference	Ground Floor	0.4
Interpreters room	Ground Floor	0.3

SPONSOR

VOLVO CAR CORPORATION

Since its creation in 1927 Volvo has always put people first and safety is therefore Volvo Cars' guiding principle. The integral care for people and the environment is an increasingly important theme of our Company. Volvo Cars takes Corporate Citizenship very seriously. We are proud to be able to make a contribution to government transport and pleased that we have been given the opportunity to support this Conference.

VOLVO

for life

water for food
and ecosystems



Buitenlandse
Zaken



agriculture, nature
and food quality

*make it
happen*