

# Structures assisting the migrations of non-salmonid fish: USSR

FAO  
FISHERIES  
TECHNICAL  
PAPER

308

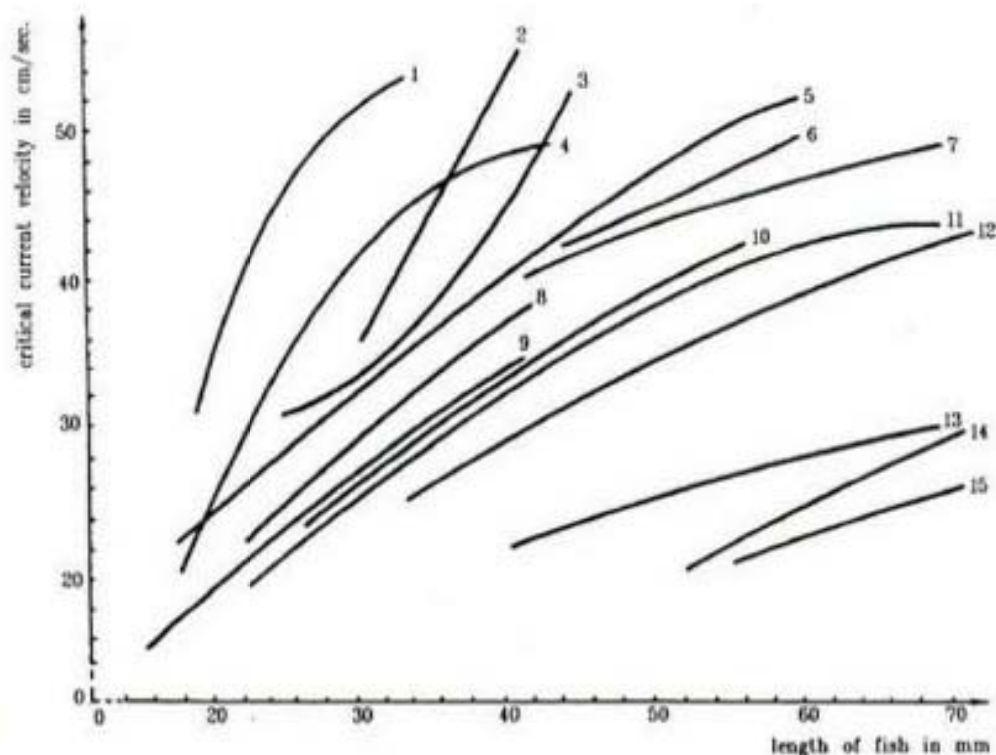

FOOD  
AND  
AGRICULTURE  
ORGANIZATION  
OF THE  
UNITED NATIONS

# Structures assisting the migrations of non-salmonid fish: USSR

FAO  
FISHERIES  
TECHNICAL  
PAPER

**308**

**D.S. Pavlov**

Severtsov's Institute of the Evolutionary  
Morphology and Ecology of Animals

Leninskii Prospekt 33

117071 Moscow B-71, USSR



FOOD  
AND  
AGRICULTURE  
ORGANIZATION  
OF THE  
UNITED NATIONS  
Rome, 1989

The designations employed and the presentation of material in this publication do not imply the expression of any opinion whatsoever on the part of the Food and Agriculture Organization of the United Nations concerning the legal status of any country, territory, city or area or of its authorities, or concerning the delimitation of its frontiers or boundaries.

M-42  
ISBN 92-5-102857-5

All rights reserved. No part of this publication may be reproduced, stored in a retrieval system, or transmitted in any form or by any means, electronic, mechanical, photocopying or otherwise, without the prior permission of the copyright owner. Applications for such permission, with a statement of the purpose and extent of the reproduction, should be addressed to the Director, Publications Division, Food and Agriculture Organization of the United Nations, Via delle Terme di Caracalla, 00100 Rome, Italy.

© FAO 1989

## PREPARATION OF THIS DOCUMENT

The Working Party of Experts on Inland Fisheries of the Indo-Pacific Commission, at a meeting in New Delhi, India, in January 1984, recommended that information be collected on the use of fish-passes. As a result of this recommendation, FAO commissioned a consultant to review structures assisting migration of non-salmonid stocks in the USSR. The original manuscript has been subject to substantial editing by Drs R. Hughes, J. Muir and T. Petr and any inadvertent alterations in sense or emphasis should be attributed to the technical editors.

Another publication on the same subject, dealing with Latin America, by R. Quiros, is published as Copescal Technical Document 5.

### Distribution

FAO Fisheries Department  
FAO Regional Fisheries Officers  
Selector Short Inland  
EIFAC  
COPESCAL  
CIFA  
IPFC

Pavlov, D.S.  
Structures assisting the migrations of non-salmonid fish:  
USSR.  
FAO Fisheries Technical Paper, No. 308.  
Rome, FAO, 1989. 97 p.

#### ABSTRACT

This technical paper provides information on provisions, made in the USSR, to facilitate fish migration under conditions of modified river flow resulting from engineering construction and water abstraction. The fish-pass and fish protection structures described utilise a knowledge of the physiology, biology, ecology and behaviour of the migrating species. The principles of their design and operation are elaborated in relation to characteristics of the species of fish concerned. Structures described include sluice fish-passes, hydraulic and mechanical fish-lifts and mobile devices for fish collection and transfer, together with protection and guiding devices used to ensure downstream migration of young fish.

## CONTENTS

<b>1</b>	<b>INTRODUCTION</b> .....	<b>1</b>
<b>2</b>	<b>FISH MIGRATION UNDER CONDITIONS OF REGULATED WATER FLOW AND WATER ABSTRACTION</b> .....	<b>3</b>
	2.1 General aspects of fish migrations .....	3
	2.2 Responses to stressors in fishes .....	5
	2.3 Fish behaviour during spawning migrations .....	7
	2.4 Behaviour of young fish during downstream drift migrations .....	9
	2.5 The impact of water intake devices on migrating fish .....	11
	2.6 The impact of other stress factors on migrating fish .....	11
<b>3</b>	<b>STRUCTURES AND MEASURES WHICH FACILITATE SPAWNING MIGRATIONS</b> . . .	<b>13</b>
	3.1 Structures in use .....	13
	3.1.1 Hydraulic fish-lifts .....	14
	3.1.2 Mechanical fish-lifts .....	16
	3.1.3 Sluice fish-passes .....	17
	3.1.4 Mobile devices for fish collection and transfer .....	19
	3.1.5 Other types of fish-passes .....	22
	3.2 Biological bases for the design and use of fish-passing devices .....	22
	3.2.1 Fish distribution in the tail-waters of dams .....	22
	3.2.1.1 Observations on fish distribution .....	22
	3.2.1.2 Studies of fish distribution using models of hydraulic schemes .....	25
	3.2.1.3 Fish distribution in relation to the location of fish-passing devices .....	26

3.2.2 The attraction of fish to fish-passing devices .....	28
3.2.2.1 The attracting flow .....	28
3.2.2.2 Hydraulic schemes of fish attraction and the arrangement of hydraulic works .....	31
3.2.2.3 Blocking and guiding devices .....	35
3.2.3 Fish behaviour and optimisation of fish-pass performance .....	36
3.2.3.1 Fish behaviour in fish passes and collectors .....	36
3.2.3.2 Conditions for fish release and their onward migration .....	38
4 STRUCTURES AND MEASURES EMPLOYED TO ENSURE THE DOWNSTREAM MIGRATION OF YOUNG FISH .....	39
4.1 Problems with water intake devices .....	39
4.1.1 Seasonal dynamics of fish entrapment by water intake .....	39
4.1.2 The daily dynamics of entrapment by water intakes .....	40
4.1.3 Other patterns of fish entrapment by water intakes .....	40
4.1.4 Causes and mechanisms of fish entrapment by water intakes .....	41
4.2 Fish protection measures .....	43
4.3 Fish protection based on ecological observations .....	44
4.4 Physical methods and devices for fish protection .....	47
4.4.1 Screening methods .....	47
4.4.2 Circulatory separation methods .....	49
4.4.3 Air-lift methods .....	49
4.5 Methods of protection which exploit fish behaviour .....	51
4.5.1 Methods using light .....	51
4.5.2 Methods using electrical stimuli .....	52

4.5.3 Methods employing hydraulic stimuli .....	54
4.5.4 The use of tactile-hydraulic stimuli with permeable barriers	57
4.5.5 The use of tactile-hydraulic stimuli with impermeable barriers	62
4.5.5.1 Principal designs	62
4.5.5.2 Fish behaviour in front of a barrier .....	66
4.5.5.3 The effect of various factors on diverting efficiency	67
4.5.5.4 Fundamental hydraulic indices and their inter-relationships	70
4.5.5.5 Fish-protection devices with and without diversion	72
4.6 The suitability of different fish-protection methods .....	74
5 CONCLUSION .....	77
REFERENCES .....	80
GLOSSARY OF SYMBOLS AND NOTATIONS .....	89
APPENDIX 1 (List of species cited in text) .....	91
APPENDIX 2 Plates .....	92





## 1. INTRODUCTION

This work describes the provisions made in the USSR for fish migrations under conditions of modified river flow resulting from engineering construction and water abstraction.

A continuous increase in the use of water resources has accompanied the development of various aspects of the national economies of all industrialised countries. Water resources are being used for agriculture, energy, manufacturing industry, municipal development and water transport. In the USSR, during the last few decades, the environment of most rivers has been changed considerably. Many which support important fisheries have been impounded and contain large dams, and streamflow is now regulated. The annual volume of water consumed in the USSR has reached 350 km<sup>3</sup>, and there are about 30 000 devices for abstracting water. At present the total surface area of reservoirs is about 10 million hectares, which is about a quarter of the total area of all natural lakes in the USSR. There are tens of thousands of kilometres of large artificial waterways, including irrigation and shipping canals, and dams regulate the outflow of most medium to large lakes, providing a further regulated surface of some 6 million hectares. Many river basins have been connected by shipping canals and inter-basin water transfer regularly occurs between some catchments. This exploitation of water resources has radically altered the ecological balance of many inland water bodies, and in some cases has led to sharp decreases in stocks of some food fish, *e.g.* in the basins of the Aral, Azov and Caspian Seas. Some fish species are now endangered and are listed in the USSR Red Book, and the Red Books of the individual Soviet Republics.

Migration is an important feature of the biology of many fish species, and the enormous intensification of water use by man in recent years has affected migrations adversely. The task of minimising the effects of impoundments and water abstraction schemes on fish stocks is complex and requires close co-operation of planners, biologists, engineers and decision makers.

The best studies of migratory fish are those on salmonids which have been extensively investigated in the USA, Canada, Great Britain and several other countries. These have enabled engineers to develop successful means of assisting salmonid migrations. Reviews by Collins & Elling (1960), Clay (1961), Trefethen (1968) and Ebel (1985) indicate progress to date and identify outstanding questions.

In the USSR, apart from Salmonidae, there is a need to protect representatives of Acipenseridae, Anguillidae, Clupeidae, Coregonidae, Cyprinidae, Percidae, and Siluridae during their migrations. This work concentrates on provisions made to assist the migrations of **Acipenseridae**, Clupeidae, Cyprinidae, Percidae and Siluridae in rivers traversing the southern slopes of the European region of the USSR, in the basins of the Caspian, Azov, and Black Seas, and in particular on the Volga, Don and Kuban' Rivers.

The behaviour of different species, the peculiarities of river hydrology, and the traditional fishing practices on different rivers, combine to pose problems which require different solutions from those used for Salmonidae. However, the development and use of fish-passes and fish-protecting devices have much in common for all species.

One approach to the rehabilitation of fish stocks now widely applied throughout the Soviet Union, is the stocking of rivers with fish reared in hatcheries. Hatcheries have been constructed in the lower reaches of rivers, and at present about 11 x 10<sup>10</sup> young fish are released from them annually. For example, in the Volgo-Caspian Basin, some 90 million young Acipenseridae, 18 million Caspian inconnu (*Stenodus leucichthys leucichthys*), and 0.6 million Kura salmon are stocked each year (Nikonorov, 1984). However, despite the success of these measures, it is recognised that the total replacement of naturally reproducing populations with artificial ones by regular stocking is unwise because it leads to the impoverishment of the gene pool and reduces the ability of the populations to survive the hazards of environmental change. Any

interruption, even of short duration, of the programme of regular stocking would be detrimental. Thus protection of naturally reproducing populations is an essential part of any fishery programme to be implemented in an area of intensive water use. This, in turn, makes it imperative that migratory paths be preserved.

In the USSR, since the 1960s, attention has been given to fish stock protection by the regular stocking of waters with hatchery-produced fry and fingerlings. A number of special research organisations have been established, the most important of which are: The Institute of Evolutionary Animal Morphology and Ecology of the USSR Academy of Sciences, The Caspian Scientific Research Institute of Fisheries and The Institute of Inland Water Biology of the USSR Academy of Sciences. The hydraulic, hydro-technical and design works are carried out by '*Gidroproekt*', The Kalinin *Polytechnical* Institute, The Novocherkassk Engineering and Land-Reclamation Institute, The All-Union *Scientific-Research* Institute of Hydrobiology and Hydroengineering, The Tuzhnyi' State Institute of Design for the Water Industry and The Ukrainian State Institute of Design for the Water Industry. Special conferences have been held since 1965, and the work of the aforementioned institutes has been co-ordinated by the State Committee on Science and Techniques of the USSR since 1972. Since the adverse effects of river regulation and water abstraction were first recognised, some 400 works on various aspects of the problem have been published, among them a series of special monographs, and a number of reviews, e.g. Tikhii & Viktorov (1940); Kharchev (1940); Birznek & Kipper (1960); Kipper & Mileiko (1962); 'Fish Behaviour in the Area of Hydro-technical Facilities' (1967); Tsyplyaev (1973); Pavlov & Pakhorukov (1973, 1983); The biological foundations of employing fish-protecting and fish-passing devices' (1978); Pavlov (1979); Shkura (1979); Barekryan (1980); Mussaenko *et al.*, (1982); and Malevanchik & Nikonorov (1984).

## 2. FISH MIGRATION UNDER CONDITIONS OF REGULATED WATER FLOW AND WATER ABSTRACTION

In order to permit fish migrations in rivers it is necessary to maintain conditions which help migrants reach their spawning grounds. To overcome obstacles, such as dams, placed in the path of migrating fish, structures must be designed to assist the fish to pass them. The efficiency of such fish-passing structures depends to a large degree upon the ability of engineers to utilise knowledge of the physiology, ecology and behaviour of the migrating species. These matters are discussed in this section.

### 2.1 GENERAL ASPECTS OF FISH MIGRATIONS

The phenomenon of migration, although manifested to different degrees, is characteristic of both anadromous and semi-anadromous fish, as well as for some species which live only in fresh water bodies. The common biological significance of all migrations is that they provide complex use of the full range of a

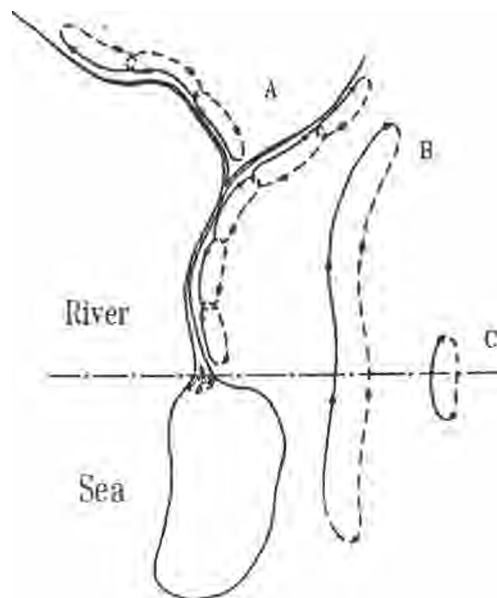

Figure 1. — Migratory paths of fish. A. fluvatile species. B. anadromous species. C. semi-anadromous species. Continuous lines = spawning migrations, broken lines = drift migrations.

species according to its changing requirements at different stages of its life cycle. The scale of migrations is determined by evolutionary and ecological species-specific factors and by the conditions under which particular populations now exist (Pavlov, 1979, 1982). The study of fish population dynamics requires a thorough knowledge of their migrations. This is so because all the processes of population dynamics have spatial as well as temporal character, and are connected with the distribution of specimens throughout the range of a species.

In rivers fish migrations are associated with currents, although during the life cycle, the direction of fish movement with respect to the current often changes. Active migrations against the current (spawning migrations) generally occur together with passive, or active-passive, migrations of juveniles and recently spawned brood stock. Some authors have emphasized the occurrence of a combination of both active and

passive migrations in fish, e.g. Schmidt (1936), Harden-Jones (1968) and Marti (1980). Besides fish this combination is known only in Cephalopoda and Decapoda.

Fish migrations in inland water-bodies can be indicated by means of 'migratory rings' (Fig.1) which are 'superimposed' upon the existing system of currents: river-sea and river-lake. Unlike the idea of a migratory cycle, the term 'migratory ring' emphasizes the closeness of migrations in space, but not in time. A movement against the current during the spawning migration, and one with the current during the downstream migration, is typical of most species. However, the spatial extent of these movements differs. The ratio of the reproductive to the trophic part of a species' range has been resolved differently for different species by natural selection, but within a single species it is resolved by the actual conditions a given population experiences. The diversity of behavioural mechanisms studied hitherto (Pavlov, 1979), particularly that of downstream drift migrations, creates a definitive base for adaptive plasticity in migratory species, by contrast with the narrow specialised base of relatively settled species. Nevertheless within a settled species one may recognise a transition from resident to semi-diadromous forms, and this markedly affects population size.

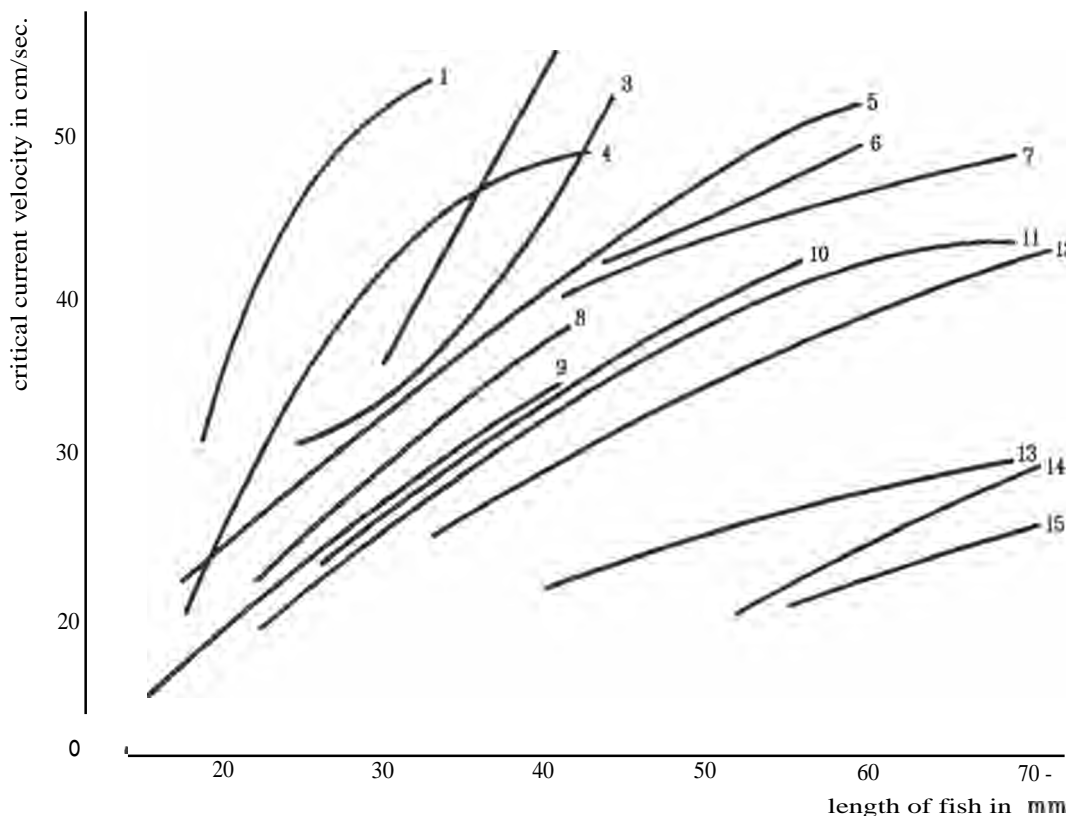

Figure 2.— Critical current velocities for different species and sizes of fish: 1. *Albumus albumus*. 2. *Leucaspis delineatus*. 3. *Rutilus rutilus caspius*. 4. *Carassius carassius*. 5. *Abramis ballerus*. 6. *Perca fluviatilis*. 7. *Vimba vimba*. 8. *Nemachilus barbatulus*. 9. *Comus gobio*. 10. *Rhodeus sericeus*. 11. *Tinca tinca*. 12. *Cobitis taenia*. 13. *Acipenser güldenstädti*. 14. *Huso huso*. 15. *Acipenser stellatus*.

## 2.2 RHEOREACTION IN FISHES

In a water current, fish are generally oriented by, and move against, the current. This is known as rheoreaction and all other behavioural peculiarities which fish exhibit in response to currents have been developmentally derived from this reaction. Rheoreaction includes orientational and locomotory components. Orientation against the current is based upon the stimulation of optical and tactile sense organs. In disturbed flows with vortex and gradient currents, which are typical of rivers, fish also use their lateral line organs and organs of equilibrium (the horizontal canal of the labyrinth) for orientation in the current. The optomotor reaction, which is manifested as a movement of the fish following a shift of cues in the field of vision, is the visual component of rheoreaction (Pavlov, 1970; Arnold, 1974).

Fish orientation in a water flow is not constant during ontogenesis. In young Teleostei the visual mechanism is the main one determining orientation. When illumination falls below the threshold for the optomotor response, fish less than 30mm long start drifting with the current.

The locomotor activity of fish in a water flow may be characterised by a number of functional indices. Threshold current velocity ( $V_{thr}$ ) is the minimum current velocity which leads to an orientation reaction against the current (values range from 1-30 cm/sec). Critical velocity ( $V_{cr}$ ) is the minimum current velocity at which fish begin to be carried away by the water flow. Bottom dwellers (Fig.2 - 13,14,15) typically have critical velocities 2-3 times lower than species inhabiting the water column or surface layer (Fig.2 - 2,6,7). Swimming performance ( $T_v$ ), is the duration of active swimming as a function of a fish's speed. The greater the speed, the lower the duration of movement, with characteristic burst, maximum and cruising speeds (Fig.3).

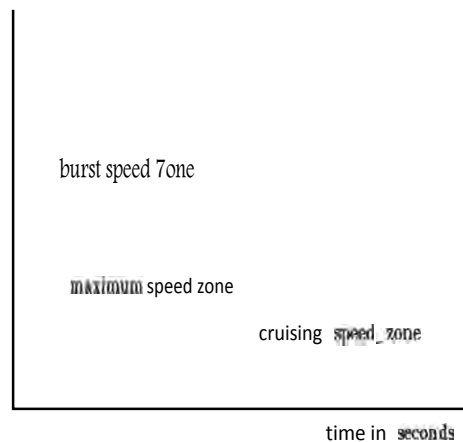

Figure 3. —The relationship between fish speed (V) and swimming duration (t).

During evolution in fishes, two main behavioural stereotypes were developed, that of pelagic and benthic fishes. Typically, in pelagic species, the visual mechanism is the dominant mechanism controlling orientation, while threshold current velocities are low and critical velocities high. In benthic species the tactile mechanism is most important for orientation, while threshold current velocities are typically high and critical velocities are low.

Rheoreaction is influenced by temperature, level of illumination, degree of turbulence, flow velocity and the physiological condition of the fish. A knowledge of the role of these parameters is crucial to the control of fish behaviour in the vicinity of hydraulic works. In a uniform flow all fish manifest rheoreaction and move against the current. Their distribution across the width of the flow is generally uniform and only bottom dwelling species exhibit a preferential movement to the peripheral zones where conditions for

tactile orientation are better. However, velocity gradients are usually very different in natural environments, i.e. in non-uniform flows, and fish consequently react differently to them. Both benthic and pelagic fish select definite current velocity zones. Two main types of reaction to a current can be discerned (*Fig.4*). The first involves precise orientation and movement against the current, where current velocities exceed  $0.3 V_c$ , (selected velocity  $V_{sel} = 0.3-0.95 V_c$ ). The second, where current velocities are below  $0.3 V_c$ , involves disorientation relative to the direction of the main flow. This is often manifested as movement in a circle. Species which spend most of their life in currents exhibit the former reaction. Species which manifest the latter reaction are those which typically inhabit sluggish water bodies (ponds and lakes) or zones of sluggish water in otherwise moving bodies. They are frequently found in zones of near-shore vegetation.

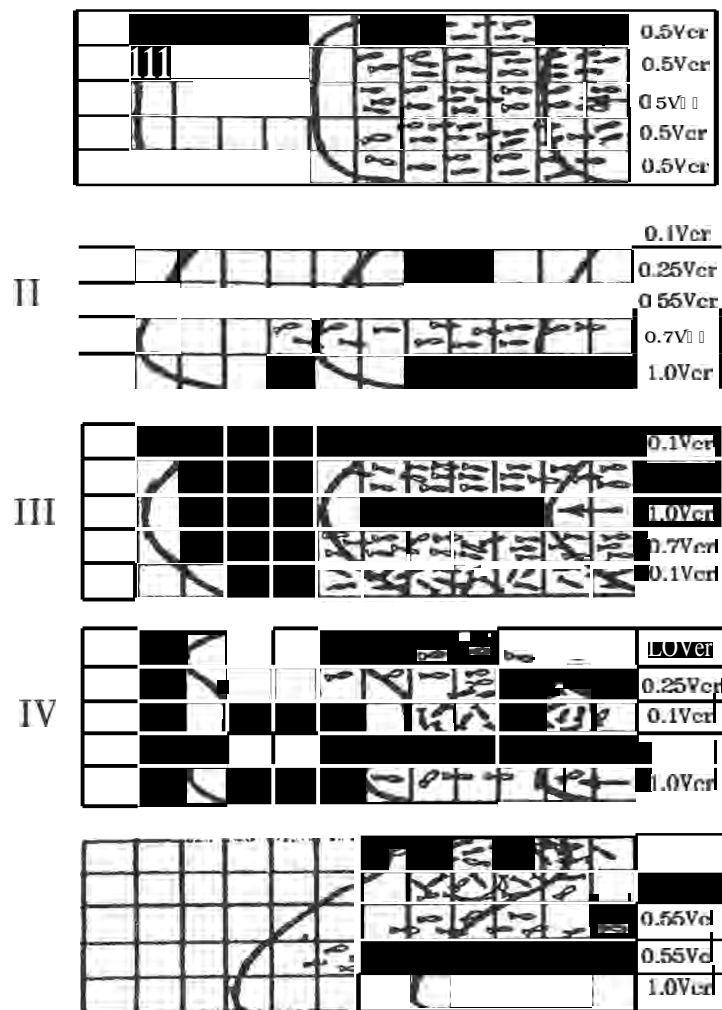

Figure 4.- Fish distributions in the light at different hydraulic regimes (I-V).  $V_{average} = 0.52V_{cr}$ , curved lines = flow velocity curves, light fish profiles = initial distribution, dark fish profiles = subsequent distribution,  $V_{cr}$  = critical current velocity for fish.

In species exhibiting the first type of reaction, the current velocities selected ( $V_{sel}$ ) are connected not only with the aforementioned factors, but also with the velocity distribution. The flatter or more uniform the velocity profile, the more  $V_{sel}$  tends to  $V$ , and to the maximum velocity in a chute. The steeper the

profile, the lower  $V_{\text{rel}}$  becomes. When the average flow velocity ( $V$ ) increases,  $V_{\text{rel}}$  also increases, but the relative influence of the steepness of the velocity profile on fish distribution is retained. It can be said that within fixed limits, where  $V_{\text{av}} < V$ , the ratio of these parameters across the width of a flow is more important in determining fish distribution in the flow than their absolute values. This ratio is the most constant factor in a flowing water body and is little affected by a variable velocity regime. Use of the velocity structure of a flowing water body allows fish to select a stable habitat.

Because migrant fish are swimming against the velocity of the flow ( $V_n$ ) it is possible to distinguish both relative ( $V_{\text{tr}}$ ) and absolute ( $V_{\text{ia}}$ ) swimming speeds ( $V_{\text{ia}} = V_n + V_i$ ). Relative swimming speed indicates the fish's speed between fixed points, while absolute speed indicates the velocity the fish would have in still water. According to experimental data (Pavlov, 1979), under conditions of uniform flow, where  $V_n >$  when  $V_n$  increases,  $V_{\text{tr}}$  and  $V_{\text{ia}}$  both increase, *i.e.* the fish over compensates for an increase in current velocity so that the margin by which its speed exceeds current velocity increases. The fish therefore increases its rate of progress upstream. However, in non-uniform flow, the ratio of these values was different;  $v_{\text{tr}}$  remained invariable despite a continuous increase of  $V_n$  over a broad range of velocities. Thus by contrast with the response in uniform flows, in velocity gradients fish maintain their relative velocity and a constant rate of progress upstream regardless of hydraulic conditions.

### 23 FISH BEHAVIOUR DURING SPAWNING MIGRATIONS

River discharges attract physiologically prepared spawners from the sea, lake or reservoir. While riverine currents impede the migratory passage of fish, because of the physical resistance they offer to their progress, they nevertheless provide the most important directional cues to spawners *en route* to the spawning grounds.

Pelagic fish, and some near-bottom **dwelling** species which rely mainly upon visual orientation, move upriver near the surface of the water column, or through shallow waters along the river banks. Examples are shad (*Alosa spp.*), Atlantic salmon (*Salmo salar*), bream (*Abramis brama*) and vobla (*Rutilus rutilus caspicus*). On the whole their migrations occur in the day-time or during twilight hours (*Fig.5a*). Illumination and not the time of day is the principal criterion for migration. Species displaying chiefly tactile orientation during migration move against the current exclusively in the near-bank waters at night (*Fig.5b*). Examples are sheatfish (*Silurus glanis*) and zander (*Stizostedion lucioperca*). Others, *e.g.* stellate sturgeon (*Acipenser stellatus*) exhibit a 24 hour pattern of migration, but with maximum movement at night. Moonlight can reduce the intensity of migratory movement in these species.

Migrating fish proceed at cruising speed, only rarely at maximum speed. If current velocities in the main river channel exceed the swimming performance of the fish they move closer to the banks seeking zones of less vigorous water flow. The presence of whirlpools or circular currents leads to the disorientation of migrants and they delay and accumulate in such places. Despite the fact that the swimming speeds of bottom fishes, notably Acipenseridae, are typically slower than those of pelagic species (0.5-1 times and 3-4 times body length/sec. respectively), the migratory progress of both groups relative to the river banks is roughly equivalent. This is due to the fact that the slower bottom fish move against slower flowing water in the near-bank zones.

Fish movements during spawning migrations are chiefly active in character and are directed upstream. Nevertheless, catches in 'passive' trap nets and data from telemetry indicate that the upstream movement of a migrating fish regularly alternates with an active-passive downstream movement. This latter movement occurs while the fishes remain with their heads into the current, but while they swim so weakly that they are carried backwards. These movements may occur because of exhaustion, but downstream drift can also take place during a renewal of orientation in the flow. As spawning time draws near, the pattern of active



upstream movement is more and more frequently replaced by the active-passive pattern in many semi-anadromous species and others which spend all their lives in rivers. The overall swimming performance of these species is reduced at this time and they are carried into side channels and oxbow and floodplain lakes where spawning occurs. Later the drift of post-spawners downstream is also connected with active-passive movement.

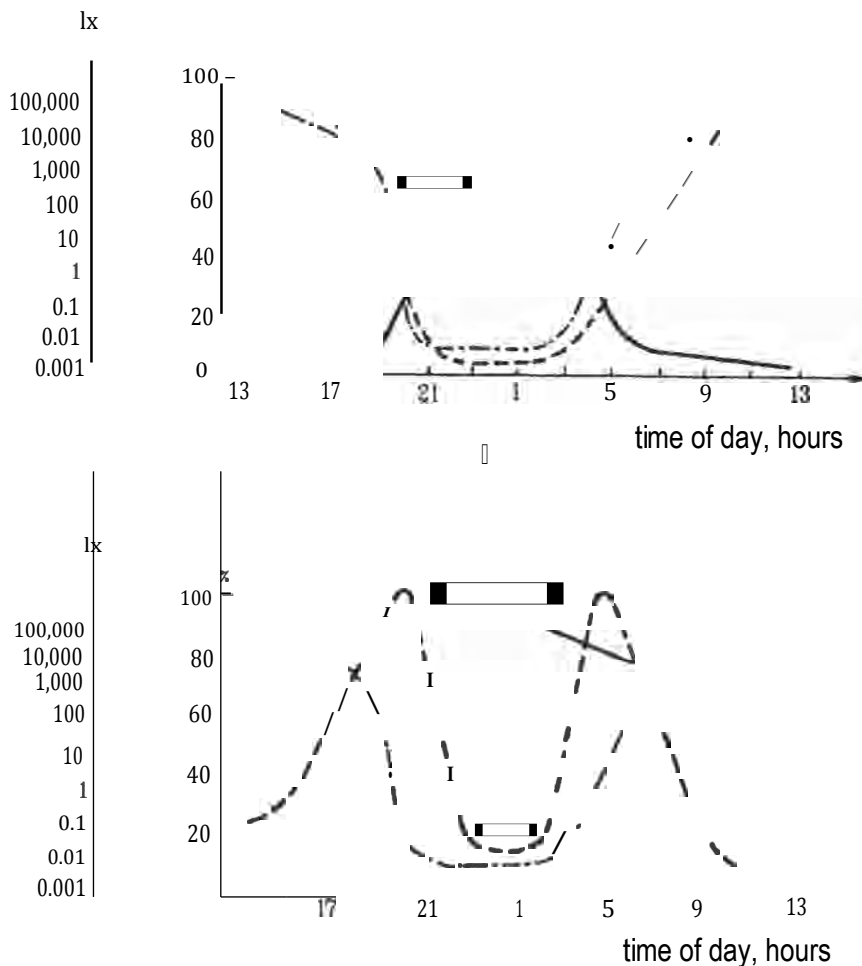

Figure 5.—Daily rhythms of fish spawning migrations. a. broken line migration during the day, continuous line migration during the night, broken line with dots illumination level. b. broken line migration during twilight hours. continuous line migration over 24 hour period, broken line with dots illumination level.  
 X axis time of day, 24 hour clock. Y axis illumination in lux and migration intensity.

Anadromous migration of fish in a regulated river ends below the lowest dam. The degree of damage caused to the fish stock depends upon the proportion of the natural spawning ground upstream of the dam which is lost. Regulation of a river can lead to a sharp diminution of a migratory population, or even to its complete elimination. As an example, populations of *Stenodus leucichthys leucichthys* and giant sturgeon *Huso huso* in the Volga River, and of Aral barbel *Barbus brachycephalus* and bastard sturgeon *Apenser nudiventris* in the Aral Sea and Lake Balkhash Basins, have been greatly depleted.

Any reduction in river discharge during the period of migratory activity diminishes the attractive potential of the river, hence the number of spawners entering from the pre-estuarine region is reduced. Because of this, regulation of a river can greatly influence the strength of migration to the non-regulated

part of the river below the lowest dam site. In this context Gorodnitchiy (1955) records that during the initial flooding of the Tsimlyanskoye Reservoir, the current of the Don River was reduced to 0.1m/sec, while that of its tributary, the Severtskiy Donets remained at 1.5-2m/sec. Two species, *Acipenser güldenstädti* (Russian sturgeon) and *Huso huso*, which hitherto spawned in the Don above the confluence of the Severtskiy Donets, entered and spawned in the tributary where they had not previously been known to breed.

Regulation of stream-flow during the migratory season, with daily fluctuations in the volume of water discharged from impoundments, leads to changes in the seasonal and daily dynamics of migration. The seasonal redistribution of run-off often eliminates the natural and regular inundation of riverine floodplains, where many fishes breed, or at least reduces the area flooded each year. Thus this process adversely affects the breeding activity of semi-anadromous species, as well as those which spend their entire lives in rivers. Either their migrations to and from the floodplains and associated lakes is precluded, or the spawning grounds are reduced in extent.

In winter, fish are in a non-migratory state, but the increase of stream flow in spring following the melting of snows provokes the movement of spawners against the current and their subsequent ascent from the wintering grounds (Balyk & Radakov, 1969). As a consequence of regulation, engineers may be obliged to discharge large quantities water solely to ensure the inception of the spawning run. On the Volga River the minimum spring discharge for fishery purposes is considered to be 65 km<sup>3</sup> of water, but the optimum discharge is 120 km<sup>3</sup>.

#### 2.4 BEHAVIOUR OF YOUNG FISH DURING DOWNSTREAM DRIFT MIGRATIONS

In considering the cause and effect relationships of downstream migrations one can distinguish mechanisms of three orders. Mechanisms of the first order create the prerequisites for migration. These mechanisms include the complexes of innate behavioural reactions and morphological peculiarities which determine the character of spatial distribution in young fish. The pelagic distribution of young fish in the presence of a current is the main precondition for a downstream migration. For example, the pre-larvae of most sturgeons exhibit spiralling vertical movements which keep them up in the water column, so that they drift with the current. In later stages, the spiral/vertical movements give way to horizontal movements accompanied by a change to active feeding and manifestation of the rheoreaction. By contrast the pre-larvae of the sterlet (*Acipenser ruthenus*), appear to maintain continuous tactile contact with the bottom so that this species does not drift into the sea. Some 70% of *Acipenser güldenstädti*, 50% of *A. stellatus* and 16% of *Huso huso* keep close to the bottom. This gives rise to differences in their migratory ranges and the duration of their migrations. *Huso huso* is the most pelagic of the sturgeons and the drift of its juveniles into the sea is rapid and quickly over. The migration of *Acipenser stellatus* lasts far longer, until late autumn, and some juveniles may even be delayed in the rivers until the next year (Pavlov *et al.*, 1981). The pelagic distribution of the young is promoted not only by their spiral/vertical swimming movements, but also by positive photoreaction, negative tactile response, low specific gravity and their departure from shelters and near bank vegetation. Their low specific gravity is due to the highly hydrated nature of their tissues and the fatty inclusions in their yolk sacs.

Second order mechanisms, given the presence of a current, make the downstream migration possible. There are several mechanisms which operate depending upon the pattern of downstream migration. Passive migrations, when the fish drift in the current without orientation to it, are most common. In this case, either the fish are physically incapable of resisting the current, as in the early developmental stages, or they lose their ability to orient themselves against the current. Visual orientation is lost as light levels fall and water transparency decreases. At a transparency in excess of 30cm migrations usually occur during the night or twilight hours. Tactile orientation is lost as fish ascend in the water column.

In active-passive migrations the heads of the fish point into the current, but they display little or no swimming activity. These migrations occur because of a sharp decrease in swimming performance brought about by such factors as starvation and low water temperatures. During active migrations, when fish exhibit downstream swimming, the rheoreaction is reduced and gives way to other reactions such as following other fish, imitation and escape/fright reactions. Such migrations usually occur in daytime and are typical of later developmental stages, e.g. fingerling stages.

The immediate conditions for the inception of passive migrations are connected with abiotic factors such as light intensity and water transparency, and are therefore obligatory in character. The drifting migrants tend to be of fairly uniform age. The conditions for beginning active and active/passive migrations are more labile in character and are often related to variable biotic factors such as population density, territorial and aggressive behaviour and, importantly, the availability of food. Thus migrations of this type are less obligatory in nature and the age range of downstream migrants is greater, depending upon the specific conditions of the river and of the year. Salmonidae migrate at 1–5 years and Acipenseridae at 0.3–5 years of age.

The mechanisms of the third order are usually connected with the spatial distribution of the fish already moving/drifting downstream. For example, at river bends one can observe the redistribution of larvae which tend to drift in the surface layers. These move towards the concave bank as a result of transverse circulation.

In a flow through a hypothetical river-reservoir-river system, a sharp change in the ichthyofauna will occur three times. Each time this involves both the spectrum of species and the numbers of individuals in the flow.

The first change is associated with the fact that some species which drift into the reservoir from the river will find the new conditions unfavourable and will perish. These will include rheophilic and lithophilic species, and probably also some pelagic ones. These latter perish because their drifting eggs settle on the bottom of the reservoir. In an unregulated system these eggs would have time to develop, but if the reservoir intervenes before they have had time to do so, they sink as the velocity of the current decreases. They become silted over and perish, usually in the upstream part of the reservoir. On the other hand, because the spawning stock is present, the numbers of phytophilic and eurybiotic species increase sharply in reservoirs.

The second change is connected with the release of species from the reservoir back into the river. Not all fish leave the reservoir, and the spectrum of species and their relative numbers leaving it is different from that which would have inhabited the river had the reservoir not been constructed. Some migrating individuals may be delayed in reservoirs for several years, e.g. members of Acipenseridae.

A third change may occur if the dam is equipped with hydroelectric generators, and is associated with trauma as fish pass through the turbines of the power plant. Because of the changes in hydrostatic pressure, swim bladders rupture, and other internal damage occurs. As an example of the damage done to fish stocks in a regulated river, 19 species are present in the drift of the Ili River above the Kapchagayskoye Reservoir, but below it only one of these is present, and moreover, the abundance of this single species is dramatically reduced (Pavlov *et al.*, 1981; Nezdolij, 1984).

The migration of young fish in a river below a dam is greatly influenced by the dam. Downstream of the dam, the seasonal dynamics of volume flow and water level are altered and both may be subject to short term fluctuations. The thermal and hydrochemical regimes are also altered and transparency is increased because suspended material settles in the reservoir. The total time required for downstream migration changes. For example, the passage of *Acipenser stellatus* takes longer, the young being delayed in reser-

voirs, but by contrast, the migratory path of *Huso huso* is shortened in regulated rivers and migration is therefore accomplished in less time than formerly.

Physical factors also affect **migration**. Increased transparency in reservoirs gives rise to twilight/night drift patterns, which reduce the total speed of migration and hence increase the total time required for the process. Trauma caused by changes in water pressure can also change the regular pattern of migration in species such as *Percu fluviatilis*; the vertical distribution of this species has been changed in the upper Volga River as a result of pressure changes. Further disruption of normal patterns is caused by large discharges from dams which result in major increases in current velocities. In 1974, when water levels were high in the lower Volga River following such discharges, fingerlings of *Acipenser gildenstädti* were caught in the delta 550km below Volgograd, but in the following year, when water levels were low, the greatest density of fingerlings was found 150km above this region (Pavlov et al., 1981).

## 2.5 THE IMPACT OF WATER INTAKES ON MIGRATING FISH

The volume of water removed from natural water bodies is rising. At present about 150 km<sup>3</sup> of water is used annually in the USSR for irrigation (Pavlov & Pakhorukov, 1983). The removal of this water is accomplished by some 30 000 intake devices of varying capacities, which are chiefly located on inland waterways and water bodies which support fisheries. Attention is therefore being focussed on ways of preventing young fish from being killed in all kinds of intake devices. Fish moving downstream enter water intakes by the natural processes of drift migration, and may end in artificial waterways (such as irrigation canals) where conditions do not favour their survival.

Most literature dealing with this problem considers the extent of the damage caused to fisheries by water intakes, and the data presented permit the calculation of an index of relative damage per unit of water intake capacity (1m<sup>3</sup>/sec) during a season. This damage may exceed the production capacity of the hatcheries. The total capacity of hatcheries in the USSR is about 12 x 10<sup>10</sup> young fish per year, while in the delta of the Volga River alone, some 14 milliards of young food fish are lost in water intake devices (Moisseev & Dubinina, 1987). In addition to this, the water intakes restrain the downstream drift migration of young fish along the river banks. This is connected with the fact that the devices are located near banks or at floating pumping stations, and that they produce rheogradients in these places. Further, the artificial illumination of these sites at night causes young fish to congregate around them, further inhibiting downstream migration, increasing fish concentration, and thus greatly increasing the numbers entering the intakes (Pavlov, 1970; Vatshinnikov, 1986; Zhidovinov et al., 1986).

## 2.6 THE IMPACT OF OTHER STRESS FACTORS ON MIGRATING FISH

Navigation of inland waters exerts a negative influence upon fish migrations. Beside the mechanical action of marine engines, navigation exerts a profound influence on the spatial distribution of migrating fish, since fish move away from navigated channels, or at least from vessels traversing them. The waves from passing vessels tend to damage or destroy littoral biotopes which are particularly important foraging grounds for young downstream migrants. The greatest damage is, however, caused by the operation of vessels with water jets. The prohibition of the use of such vessels in the upper Volga River, above Kalinin, resulted in a significant increase in the recruitment of fish (Pavlov et al., 1981).

The creation of navigation canals, locks and fish-passes, and the artificial interconnection of river basins has enabled some species to expand their ranges through extended migrations. The plankton-eating European smelt (*Osmerus eperlanus eperlanus*) travels from Belaye Lake in the north, southwards, and is now common down to the Kuybyshevskoye Reservoir. The tyulka (*Clupeonella delicatula morpha* tshar-

*chalensis*) moves north from the Volga Delta as far as the Kama River reservoirs and west into the reservoirs of the Don River (Kuderskiy, 1970). These extensions of range are attributable to the formation of a man made pelagic environment throughout the length of those waterway systems.

When channels are artificially tapered, or the flow is piped during the construction of roads or railways, current velocities are increased, often to levels which fish find insurmountable. This adverse influence upon migrations could be avoided if the swimming speeds of the migrating species were known and were taken into account when designing such structures.

Many of the factors known to influence migrations negatively continue to increase, e.g. chemical and thermal pollution of waterways, the canalisation of streams, and the passing of high voltage electrical transmission lines over or along rivers. It is known that the electro-magnetic fields produced by power lines delay some migrating spawners (Poddubniy *et al.*, 1978, 1979).

### 3. STRUCTURES AND MEASURES WHICH FACILITATE SPAWNING MIGRATIONS

#### 3.1 STRUCTURES IN USE

Structures that assist fish to pass dams are variously called fishways, fish ladders or fish-passes. They are of two types. In the first, the fish swim upstream, aided by the device. In the second, the fish enter a storage compartment and are transferred to the reservoir above the dam without expenditure of energy on their part.

The first group includes pool and weir, and pool and orifice types of fish-pass. Pool and weir type fish-passes are used where the dam to be surmounted is less than 10m high, while pool and orifice fish-passes may be used up to 40m. The structures of this group are used mainly by strong swimmers *e.g.* salmon

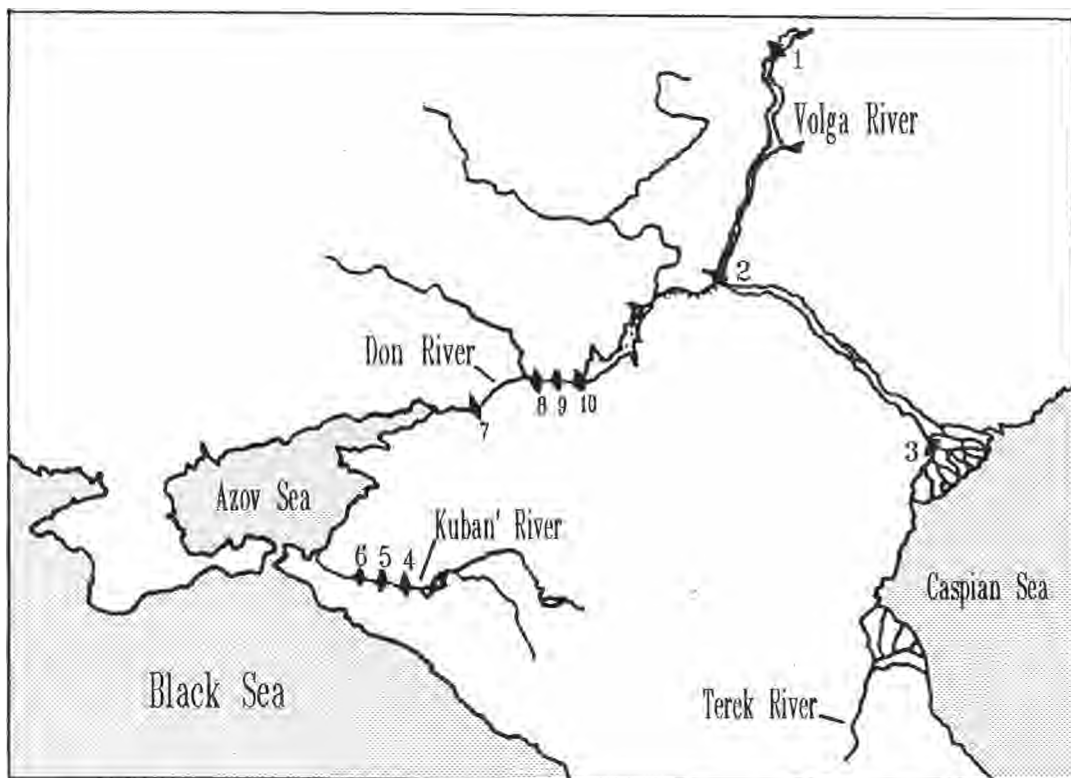

Figure 6.— Location of fish passes on the Volga, Don & Kuban' Rivers. Reservoirs and flow-dividers:  
 1.Saratovskiy, 2.Volgogradskiy, 3.Flow-divider, 4.Krasnodarskiy, 5.Fyodorovskiy, 6.Tikhovskiy, 7. Kochetovskiy,  
 8. Nikolaevskiy, 9. Konstantinovskiy, 10.Tsymlyanskiy.

The second group includes sluice fish-passes, useful up to 10m, fish locks, used up to 40m, and mechanical lifts which store and transport fish, and may be used to up to any height. Fish-lifts typically comprise a collection gallery; an operation chamber containing a fish-retention grid, where fish may be counted and samples taken; and a moving and a releasing device. The passage of water through the dam's turbine and the collection gallery creates a plume in the tailwater below the dam. This attracts fish which swim up the plume and enter the collection gallery. After a fixed time interval the gallery inlet is closed by a retaining and crowding device, which is usually a frame covered with netting. This prevents the fish from drifting back into the tailwater pond. The crowding device is then moved towards the dam when the fish

are shepherded into the operation chamber. Subsequently they move from this chamber into fish-pass sluices, or into the containers of fish locks, or into hydraulic fish-lifts. The outlet chutes of fish-pass sluices are designed to create conditions which both assist the release of the fish into the reservoir above the dam and favour their onward migration.

In the USSR, fishery complexes are often placed some distance downstream from the hydraulic projects which they serve, unlike sluices and fish-lifts, which are situated close to the dams. These complexes commonly include floating fish-collectors, fish-guiding devices, floating containers, and, where there is no navigation sluice, motorised devices to move the fish to the reservoir.

In the Soviet Union there are more than twenty different designs of fish-passes. The location of these structures on the main regulated rivers of the European part of the USSR, is shown in *Fig.6*. The main data on fish-passes are given by Tikhii & Viktorov (1940); Kharchev (1940); Kipper & Mileiko (1962); **Nikonorov** & Kutyanina (1976); Shkura (1979); Issaev & Karpova (1980) and Malevanchik & Nikonorov (1984).

### 3.1.1 HYDRAULIC FISH-LIFTS

Three hydraulic fish-lifts have been constructed in the USSR: the Tsimlyanskiy (Don River), Volgogradskiy (Volga River) and Volkhovskiy (Volkhov River) fish-lifts. The **Tsimlyanskiy fish-lift** (*Fig.7*) was built in 1955 to assist the migration of Acipenseridae, *Clupea harengus* and vimba (*Vimba vimba*). It is located below the hydroelectric station, and includes:

- a fish collection gallery (110m long, 6m wide and 6.5-13.6m deep),
- a fish pool (5x18m and 4.2-11.6m deep) with regulating valve and crowding screen. The fish-pool is an extension of the collection gallery and is connected to the shaft.
- a vertical shaft (area 7x5m, height 36.8m) which has a metallic, horizontal, crowding screen,
- an upper outlet chute (width 6m, length 65m, water depth 2-7m),
- a 4MW hydroelectric turbine set, and
- a control panel.

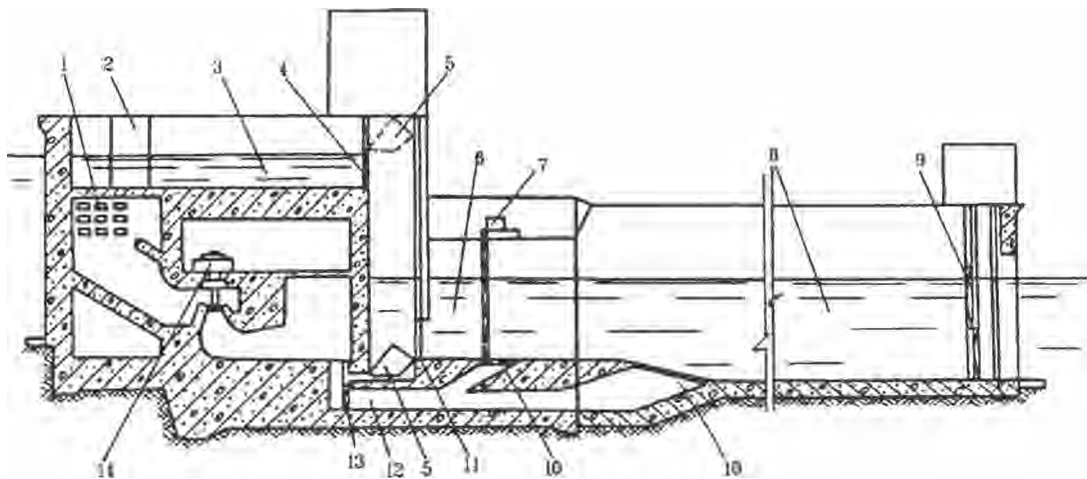

Figure 7.—The fish-lift of the **Tsimlyanskiy** hydraulic scheme on the Don River 1. water-intake screen, 2. outlet chamber, 3. outlet chute, 4. stoplogs, 5. lifting container, 6. chamber, 7. retaining screen, 8. collecting gallery, 9. regulating gate, 10. fish-retaining screens, 11. tailwater gate, 12. water outlet, 13. drawing tube gate, 14. hydro-electric unit.

The fish lift operates from April until November, and each cycle lasts for 2.5 to 3 hours. In the first few years *Acipenseridae* entered individually, but *Clupea harengus* did not enter, even though they approached the hydroelectric station in large quantities. Other fish which have entered the fish-lift include *Abramis brama*, *Cyprinus carpio*, sabrefish (*Pelecus cultratus*) and sheatfish (*Silurus glanis*). The fish-lift was reconstructed in 1972 in order to increase its efficiency and at this time the system of attracting fish into the fish collection gallery was improved.

The Volgogradskiy hydraulic fish-lift (Fig.8) was built in 1961 at the damsite of the Volzhskaya hydroelectric dam and is located between the power station and the weir. It was designed to convey *Acipenser gildenstädti*, *A. stellatus*, *Clupea harengus* and *Stenodus leucichthys leucichthys* among other fish, and consists of:

- a two-stream collection gallery (width 8.5m, length 82.25m, water depth 5.7-14.4m),
- two vertical shafts (8.5x8.5x36.9m) with horizontal and vertical metallic crowding screens,
- an upper one-stream chute (100x12x8m) with three openings (4.8x8.5m) in the longitudinal wall at the side of the weir,
- a turbine set (UMW), which creates the water movement in the collection gallery, and
- a control panel.

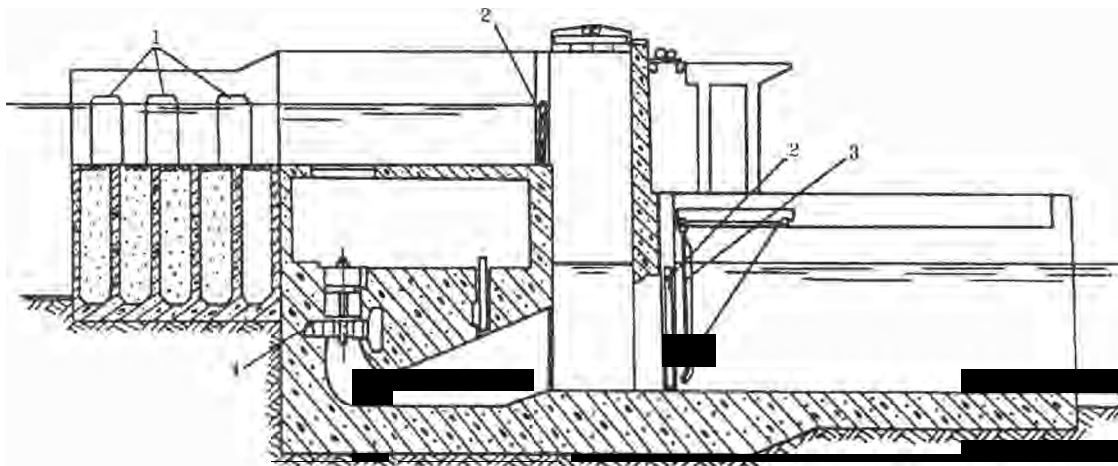

Figure 8.— The fish lock of the Volzhskaya hydroelectric dam on the Volga River 1. outlet orifices, 2. operational gates, 3. crowding device, 4. hydroelectric unit

Control of the fish-lift is automatic, and each cycle lasts 1.5-2.0 hours. Fish are attracted into one shaft, while the other is engaged in the transport of fish to the reservoir. According to the Volgograd branch of the State Scientific Research Institute of Lake and River Fisheries (*GOSNIORKH*) about 200 000-700 000 *Acipenseridae* spawners approach the dam from the Caspian Sea. An average of 20 000 specimens pass through the fish-lift annually, with a maximum of 60 000 during 1967. In total, more than a million fish of different species, pass through the lift each year.

The Volkhovskiy hydraulic fish-lift was constructed in 1967, based on the design of the Volgogradskiy fish-lift and facilitates the passage of whitefish (*Coregonus lavaretus baeri*) among some other species.



### 3.1.2 MECHANICAL FISH-LIFTS

Mechanical and hydraulic fish-lifts differ in the ways that the fish are transported. In mechanical fish-lifts the fish are conveyed in special tanks. Functional examples of this type are located at the Saratovskiy (Volga River) and Krasnodarskiy (Kuban' River) schemes.

The **Saratovskiy** mechanical **fish-lift** (Fig. 9) was built in 1969 on the Volga River above the **Volzhskaya** hydroelectric dam to allow the migration of Acipenseridae, *Abramis brama*, *Clupea harengus*, *Cyprinus carpio* and several other species. It consists of:

- a collection gallery, 8m wide, 172m long, with water 9-13.5m deep,
- a shaft (6x8m) with separating screen,
- a turbine hydro-set (power 9.5MW) with a two branch drawing tube of vertical design,
- an outlet chute with the intake basin (width 8m), and
- a control panel.

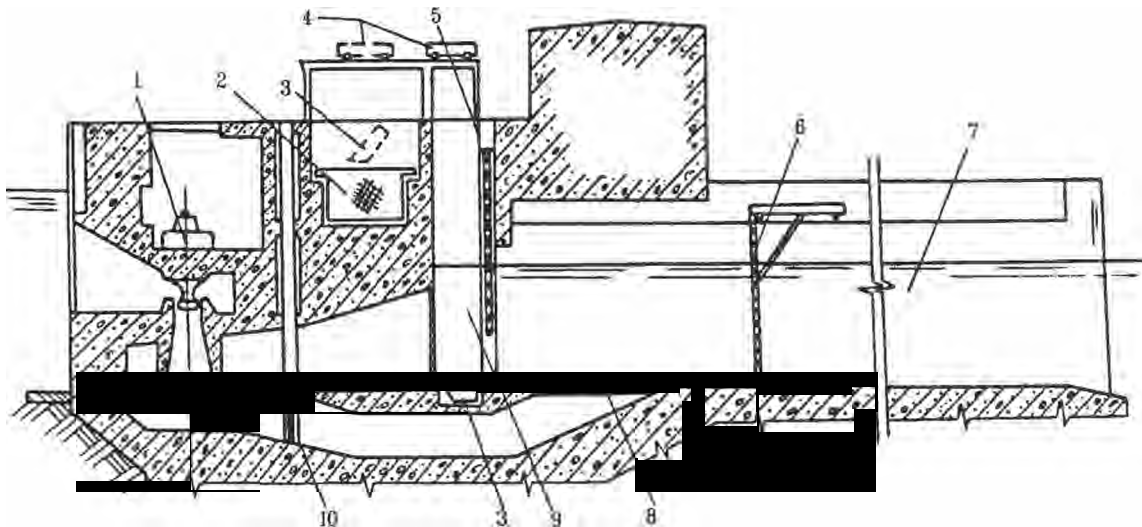

Figure 9.— The fish-lift of the Saratovskiy hydraulic scheme on the Volga River. 1. hydroelectric unit, 2. vertical crowding screen, 3. fish container, 4. mechanism for raising and transporting container, 5. separating screen, 6. crowding device, 7. collection gallery, 8. fish-retaining screen, 9. working chamber, 10. by-pass gate.

A by-pass gate directs the flow into either the upper or the lower part of the entry port ('drawing' tube). Fish are then attracted into the collection gallery through the upper part of the port. When this stage is complete the crowding screen is lowered into the inlet of the chute and, by moving along, concentrates the fish at one end of the chute. As the screen passes above the lower outlet, the bypass gate is raised and overlaps the upper layer of the entry port. This provides favourable hydraulic conditions for the fish to leave the collection gallery and move through the locks. At this point the flow is redirected through the lower part of the entry port. A second screen is then lowered down the side of the working chamber, and the fish are then transferred to the reservoir in containers. Up to one million fish are transferred annually by this fish-lift.

The **Krasnodarskiy** mechanical **fish-lift** (Fig.10) is located near the discharge from the weir bays, and consists of:

- a collection gallery (length 71m),
- an operation chamber, which includes a crowding screen, fish protection screen and fish container,
- a water feeding unit comprising the spillway and apron well (depth 2.7m) with the outlet having a gradient of 1:3,
- a trestle (length 58.65m), and
- a control panel.

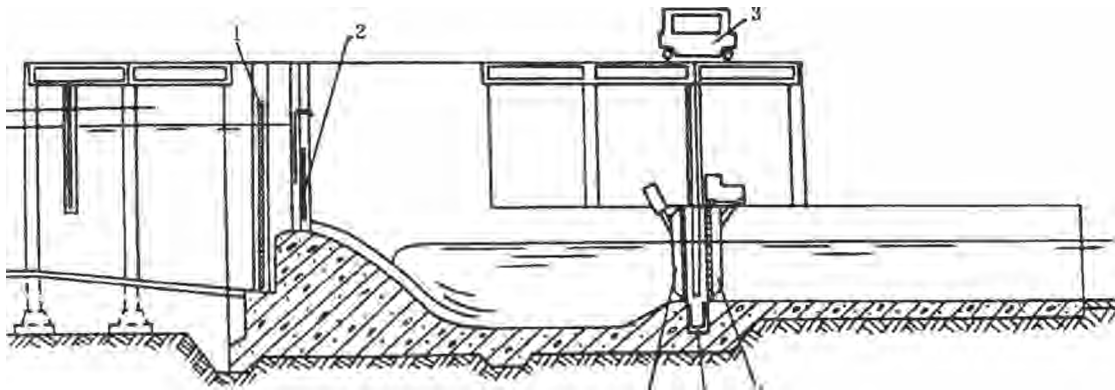

Figure 10.— The fish-lift on the Krasnodarskiy hydraulic scheme on the Kuban' River 1. litter retaining device, 2. double section gate, 3. crane for container transportation, 4. crowding device, 5. fish container, 6. separating device.

A gate on the spillway, consisting of two independently moving sections, controls the hydraulic regime in the collection gallery. Once they have passed along the gallery the fish are crowded into a collection chamber, from which they are lifted and moved to the reservoir by crane. The lifting container contains a fish retention grid, which is used to count, separate and mark the fish. About one million fish, including *Acipenseridae*, *Abramis brama*, *Stizostedion lucioperca* and *Vimba vimba*, pass through this lift on their way to the spawning grounds each year. It has been estimated that this lift can cope with all the fish which approach the **Krasnodarskiy** hydraulic scheme.

### 3.1.3 SLUICE FISH-PASSES

Sluice fish-passes differ from fish-lifts in the design of their operation chambers. The first such fish-pass was built at the Kochetovskiy hydraulic scheme on the Don River, but there are now similar passes at the Nikolaevskiy and Konstantinovskiy hydraulic schemes on the Don River, at the flow divider on the Volga River delta, and at the Fedorovskiy hydraulic scheme on the Kuban' River.

The fish-pass of the Kochetovskiy hydraulic scheme (*Fig.11*) operates by means of locks and comprises:

- a collection gallery (length 68m, width 10m),
- an operation chamber (length 28m),
- two gates, one at each end of the operation chamber, which control the flow regime for the intake, and the transfer and release of the fish,
- an upper outlet chute, and
- a control panel.

The rig with the crowding device moves along the collection gallery and into the operation chamber. The system operates as follows:

- The fish are attracted to the collection gallery by water velocities of 0.8-1.8m/sec.
- These are varied depending upon the species present, and the intensity of the spawning run. During this period water is fed through the upstream gate, while the downstream one is raised above the water.
- The crowding device is lowered into the inlet of the collection gallery and the fish are driven into the operation chamber.
- When the crowding device has entered the operation chamber the downstream gate is lowered, and the water levels in the operation chamber and the reservoir are equalised. The fish are raised on the fish retention grid for counting, marking and assessment.
- The fish retention grid is lowered, the upstream gate is raised and the fish are released into the reservoir.

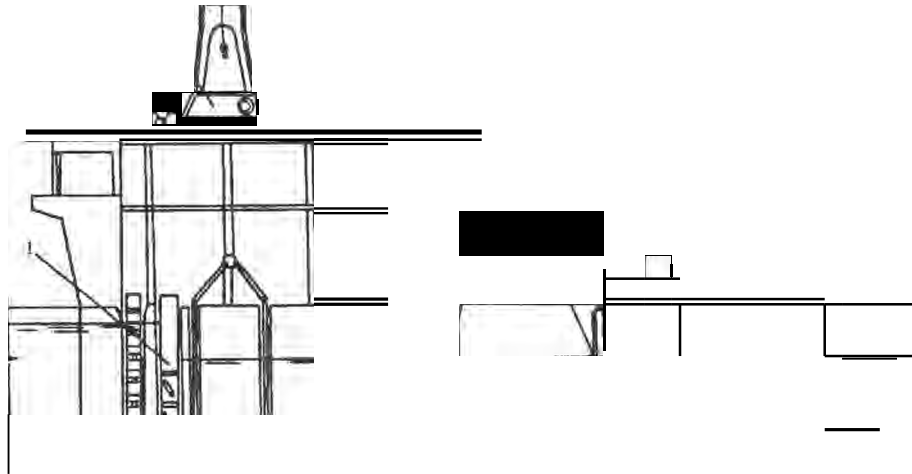

Figure 11.— Sluice fish-pass of the Kochetovskiy hydraulic scheme on the Don River 1. working gates, Z gate control mechanism, 3. fish retention grid, 4. crowding device.

The duration of the cycle depends upon the species of fish present, the flow velocity and the water temperature. About 0.5-1 million Don River fish pass through each year, including *Abramis brama*, *Acipenser gildenstädti*, *A. ruthenus*, *A. stellatus*, *Cyprinus carpio* and *Huso huso*. It has been estimated that of the fish approaching the dam, up to 67% of Acipenseridae and 44% of other fish successfully negotiate this fishway.

A similar type of fish-pass, using large reinforced concrete elements, was constructed at the Fedorovskiy hydraulic scheme in 1982 (Fig. 12). The structural elements were poured in special pits on the river bank. They were made of rigid ferro-concrete but had cellular walls and bases, which allowed them to be transported by water. This sluice was built while the hydraulic project was operational. Up to 1000 spawners of *Acipenser gildenstädti* and *A. stellatus* pass upstream through the fish-pass each year, as well as a large number of *Abramis brama*, *Stizostedion lucioperca* and *Vimba vimba* among other species.

The flow-divider on the Volga River redistributes the water between the western and eastern deltas in the interest of good fishery management. Here a two stream fish-pass has been built. It is situated between the navigation spans and the control dam of the hydraulic scheme. The fish collector consists of a two

stream chute of rectangular section (length 50m, width 9m each). The operation chamber is elongated towards the headwater, and acts as the upper outlet chute. The fish retention grid is situated between the two gates of the operation chamber. The fish-passes of the flow divider operate only in years of low water level, when the gates of the control dams are closed. They facilitate the passage of *Acipenser guldenstadti*, *A. stellatus*, *Huso huso* and several other species.

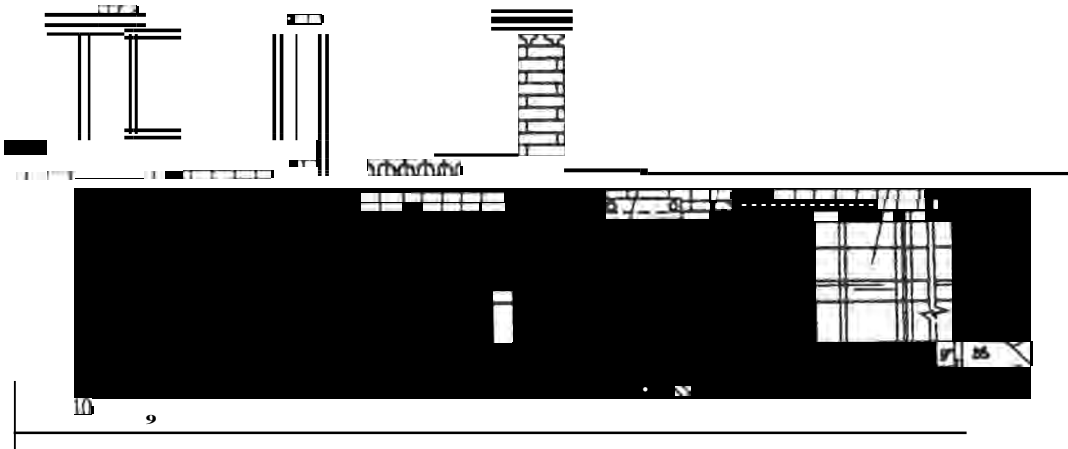

Figure 12.—Longitudinal section through the sluice fish-pass at the Fedorovskiy hydraulic scheme on the Kuban' River: 1. outlet chute, 2. litter-retaining screen, 3. gate control mechanism, 4. gates, 5. control structure, 6. crowding screen, 7. fish-collection gallery, 8. low approach chute, 9. working chamber, 10. fish-retention grid.

### 3.1.4 MOBILE DEVICES FOR FISH COLLECTION AND TRANSFER

Two types of floating units for fish collection have been constructed in the USSR, the Kochetovskiy and Nerest. The first has been used, together with motorised containers for transport, on the Ust'Manychskiy, Kochetovskiy and Fedorovskiy hydraulic schemes, and on the flow divider on the Volga River. The second is part of a fishery complex on the Rizhskaya hydroelectric power dam.

The **Kochetovskiy** collection barge (*Fig.13*) is a non self-propelled vessel with a central superstructure. The fish collector has a length of 63.9m, a chamber width of 8m, and an overall width of 13m, which permits navigation of all locks on the river. Submerged pumps create attracting plumes of water at the fish intake, and the crowding screen moves along the collection chamber to concentrate the fish above the retention grid situated at the other end of the vessel. The motorised transport vessel is a river boat, with central superstructure and deck cabin designed to connect with and move fish from the collection barge. The system operates as follows:

- The collection barge is placed in the path of the migrating fish, and is connected to the transport vessel and the pumps create suitable currents to attract fish into the device. This takes 1.5-2 hours.
- The fish are moved into the collector. The crowding screen is lowered at the inlet, and some of the pumps are switched off, so that the flow velocities do not exceed **0.4-0.5m/sec**. The crowding screen is then moved towards the transport vessel. If samples are to be taken the crowding screen is stopped close to the fish retention grid.

- The transport vessel is disconnected from the fish collector and moves to the navigation sluice, while a second empty transport vessel is connected to the collector. Currents suitable for fish survival are maintained inside the vessel during transfer.
- The transport vessel enters the reservoir and as it approaches the site where the fish are to be released, the screens are released and the vessel turned against the water flow.

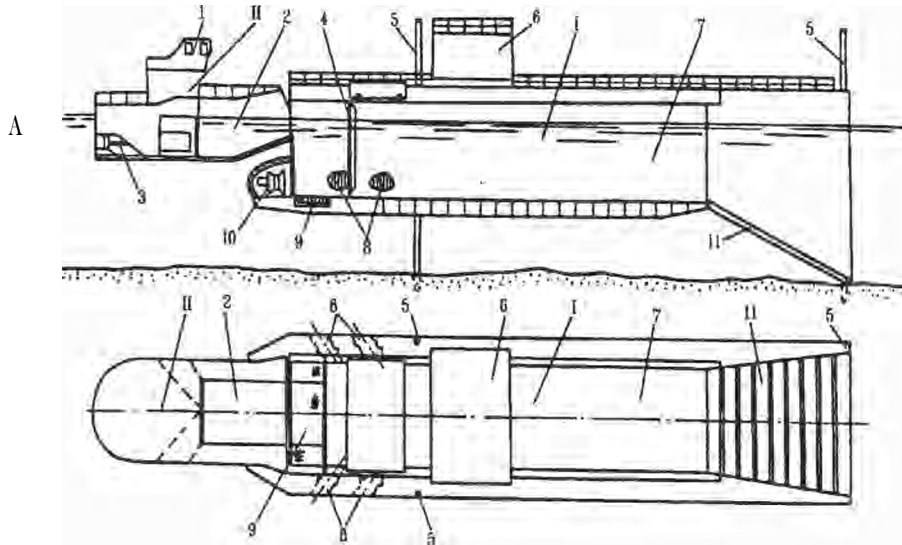

Figure 13.— Barge for fish collection and transport: A. longitudinal section, B. plan, I. fish-collector, II. transport vessel.  
 1. wheel house with control panel, 2. transport chamber, 3. motor, 4. crowding screen, 5. pile anchors,  
 6. control panel, 7. collection chamber, 8. fish collector pumps, 9. fish retention grid,  
 10. pump chamber, 11. collecting ramp.

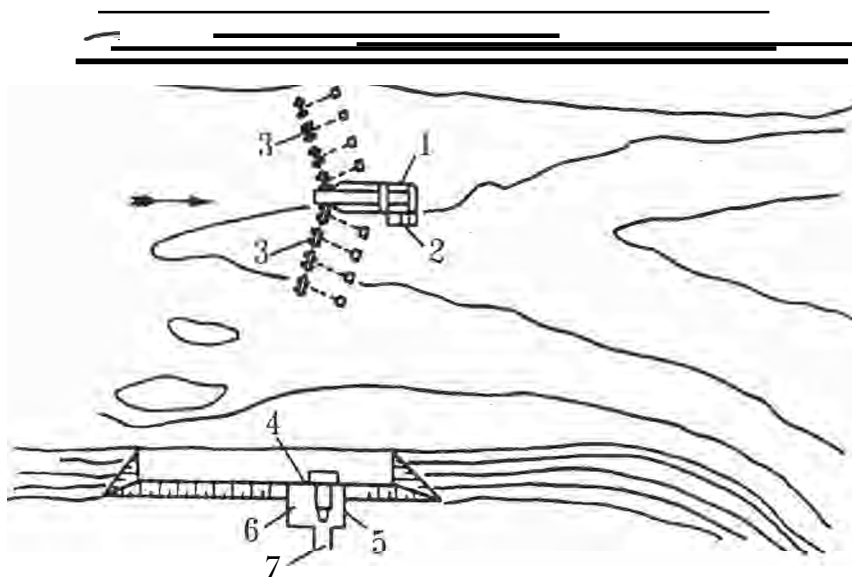

Figure 14.— Plan of the fish-passing complex at the **Rizhskaya** hydroelectric dam on the Daugava River 1. floating fish-collector, 2. transport vessel, 3. electrical guiding device, 4. mooring dock, 5. transport truck, 6. waterside area, 7. access road.

TABLE 1. DETAILS OF THE MAJOR FISH PASSES IN THE USSR

	Volgogradskiy	Tsimlyanskiy	Krasnodarskiy	Saratovskiy	Kochetovskiy	Fedorovskiy
River impounded	Volga	Don	Kuban'	Volga	Don	Kuban'
Construction begun	1961	1955	1975	1969	1969	1982
Type	hydraulic fish-lock	hydraulic fish-lock	mechanical fish-lift	mechanical fish-lift	sluice fish-pass	sluice fish-pass
Hydraulic head m	23	20	13-17	13-17	1-3	1-4
Collection gallery: length m width m flow depth m	80 8.5 5.7-14.4	129 6 <b>6.5-13.6</b>	71 10 2.5-6.5	172 8 9-13.5	68 10 1.8-4.5	69.3 9 1.4-4.8
Attractive regime: $V_{n,v}$ (m/sec) cycle time (min)	0.8-1.2 120	0.8-1.0 120	0.6-1.4 90-240	0.8-1.4 30-180	0.6-2.0 15-180	0.8-1.8 120-240
Species passed: <i>Abramis</i> spp. <i>Acipenser</i> <i>güldenstädtii</i> <i>Acipenser</i> <i>stellatus</i> <i>Chakalburnus</i> <i>chalcoides</i> <i>Clupea harengus</i> <i>Cyprinus carpio</i> <i>Coregonus</i> <i>lavaretus</i> <i>Huso huso</i> <i>Siluris glanis</i> <i>Vimba vimba</i>	+  +  +  +  +  +  +  +	+     +  +    +	+  +     +    +	+  +  +  +  +    +	+  +  +  +  +    +	+  +  +  +  +    +
Total number passed each year Number of <i>Acipenseridae</i> :	c. 1 million c. 20 000	c. 200 000	c. 1 million	c. 1 million	c. 1 million c. 2 500	c. 500000 c. 1 500

A mobile fish collector (*Fig.14*) operates on the Daugava River, **5.5km** below the hydraulic scheme. This complex includes a transport vessel, a floating electrical fish guiding device, a mooring dock and a truck to transport the fish to the spawning grounds. The truck may carry the fish for **500km**, and is designed to maintain constant water circulation, oxygen tension and temperature. Experimental tests on these systems on the Don, Kuban', Volga and Daugava Rivers have shown that valuable fish species can be transferred to the spawning sites.

### 3.1.5 OTHER TYPES OF FISH-PASSES

Other types of fish-pass have been built in Russia from 1914 to the middle of the 1960s. However, only one of these, the Niyzhne-Tulomskiy fish-pass, remains operational today, and assists the movement of salmon (*Salmo salar*) upstream. None of the other fish-passes operates at present for sundry biological or technical reasons, or because of the construction or reconstruction of hydraulic schemes they serve. Some have been replaced by more effective fish-passing mechanisms.

Canals have been built to assist spawners to move upstream to the reservoirs of some hydraulic projects, and in these, special spawning substrate is placed on the bottom of the canal. Such canals have been built at the Konstantinovskiy and Nikolaevskiy hydraulic schemes on the Don River. The Konstantinovskiy canal is trapezium shaped, 22m wide at the bottom with an average depth 2.5m, and a length of 6000m. The canal of the Nikolaevskiy hydraulic scheme is 11 500m long. Several species spawn in the canals, including Acipenseridae. However, reliable data on the efficiency of these systems are lacking.

Elsewhere, simple fishway canals have been constructed to assist migration in shallow, and thus otherwise almost impassable river sections. For example, sixteen such structures have been built on the Volga River. Table 1 summarises details of the most efficient fish-passing structures at presently operating in the USSR.

## 3.2 BIOLOGICAL BASES FOR THE DESIGN AND USE OF FISH-PASSING DEVICES

### 3.2.1 FISH DISTRIBUTION IN THE TAILWATERS OF DAMS

Tailwaters of dams create very different conditions from those normally found in free waterways. The presence of the barrier, the sharp velocity gradients, changes in the velocity regime and frequent alterations in the direction of the current, all contribute to a change in fish behaviour. It is extremely important to understand how the distribution and behaviour of fish are affected, so that the fish-pass structures and their inlets are satisfactorily placed. There have been many regrettable cases of such structures not fulfilling their intended function. Data on fish distribution in the USSR are still scarce, but what there is, is discussed in this subsection.

#### 3.2.1.1 OBSERVATIONS ON FISH DISTRIBUTION

The phenomenon of fish accumulation below dams is well known, with the greatest concentrations occurring close to the dam wall. This applies to anadromous and semi-anadromous fish, as well as true fresh water species. The lowest concentrations are observed in the winter period. In the USSR game fishing is forbidden within 500m of a dam.

According to Chikova (1968), at the Kuybyshevskaya Dam on the Volga River, *Abramis ballerus*, *A. brama*, *Leuciscus idus* and *Rutilus rutilus* populations are characterised by a predominance of older fish with only small proportions of juveniles. Only *Acipenser ruthenus*, *Pelecus cultratus* and *Stizostedion*

*lucioperca* have a full juvenile representation. However, Nussenbaum (1978) noted that immature fish as well as spawners may congregate under dams, and in some cases, even fry are found below dams.

At hydroelectric power stations, fish tend to approach the sites of greatest water discharge (Tikhiy & Viktorov, 1940; Nussenbaum, 1978; Pavlov, 1979). For example, fish move from the water diverting channels of hydroelectric stations to the wasteway sections, when they become operational. Similar phenomena have been observed at the waterworks on the Don River (Pavlov, 1979). Here, beneath the new concrete dam of the **Kochetovskiy** hydraulic scheme, most fish concentrate where the main discharge is, but prior to its construction the greatest concentrations were to be found by the old wooden shield dam with turning Poiret girders.

A widely held concept concerning fish distribution is that of the existence of a 'zone of search', *i.e.* a zone of water within which migrating fish move in their search for a passage. The front boundary of this zone has been variously referred to as 'the line of penetration', 'the zone of approach', 'the fore-front of accumulation' and 'the line of maximum velocities' (Kharchev, 1940; Tikhiy & Viktorov, 1940; Kipper, 1959; Clay, 1961; Pavlov & Pakhorukov, 1971; Pavlov, 1979). According to Clay (1961) the inlet to the fishway must be placed as close as possible to this front boundary. In his opinion, failure to observe this has been the greatest error in the design of fish-passes. It is nevertheless quite difficult to distinguish a front boundary of the search zone. In spite of the author's frequent attempts to distinguish such a boundary, only once was an obvious one found and, although this was for *Salmo salar* it is described here in some detail because of its importance in analysing fish behaviour.

The characteristic feature of *Salmo salar* is that it jumps out of the water in order to surmount obstacles. Frequent jumping was observed at the dam of the Nizhne-Tulomskiy hydroelectric power station. Maximum frequency of jumping was observed at a distance of 55-80m from the power house. In this zone, current velocities were of the order of **1.0-1.5m/sec**. This corresponds to the maximum speeds of movement for the species for which, with fish of 47 cm average length,  $V_{cr}$  has been determined as  $132.8 \pm 0.4\text{cm/sec}$ . This is in agreement with telemetric observations (Podubniy, 1971) which indicate that *Salmo salar* often overcomes a flow velocity of 0.8m/sec, but tends to drift back when the current reaches 1.2m/sec. From this it appears that the limit of the search zone may correspond to the line along which the current has a velocity equal to the maximum swimming speed of the fish.

However, many authors (Tikhiy & Viktorov, 1940; Mokryak, 1958; Birznek & Kipper, 1960; Nussenbaum, 1961, 1965, 1967, 1968; Friez & Tesch, 1965; Chikova, 1968; Pavlov, 1979) have shown that the upper boundary is not rectilinear across the stream. This is because the width of the tailwater is often irregular and is linked to the regimes of all the water discharges, including those of the hydroelectric power station, the spillways, and the fish passing structures and locks. Decrease in water discharge causes the fish to swim further upstream, whereas increase in the discharge may force the fish further downstream. At maximum discharge the number of fish near the river banks increases. It is clear that the upper boundary of the search zone has a complex and variable position, depending on the operating regime of the hydroelectric station.

It has been noted that many fish accumulate in the circular and whirlpool currents which form in the tailwaters of hydroelectric power stations (Kharchev, 1940; Schiemenz, 1957; Pavlov & Pakhorukov, 1971; Umanets, 1977; Shkura, 1974; Pavlov, 1979), where they may be trapped for long periods. Fish also accumulate in the 'hydraulic shadow' near the guide piers.

In the search zone, fish alternately swim for a period of time against the current and then drift back with it. Eventually if they cannot continue their migration they gather in quiet places or in whirlpools. For example, at the Volgogradskaya hydroelectric power station about 200 000 sturgeon accumulate under the spillway, except during brief periods of extra discharge. These accumulations under non-operational



spillways tend to persist throughout the year (Letichevskiy, 1957; Dyuzhikov, 1958; Mokryak, 1958; Kiselev, 1965; Nussenbaum, 1967, 1968; Balyk & Radakov, 1969). Similar accumulations of semi-anadromous fish, which repeatedly form and break up, are found under the **spillway** of the Tsimlyanskiy hydraulic scheme and under the dam of the Kujbyshevskiy hydraulic scheme. *Acipenser stellatus* does not form such dense nor such stable accumulations as *Acipenser guldenstadti*, and in the winter the numbers of *A. stellatus* are very low.

Judging from underwater observations, the density of sturgeon accumulating under the Volgogradskaya dam in early September 1956 reached 1 specimen per 1-1.5m<sup>2</sup>. Tests for these fish in hydrodynamic chutes showed that they were well orientated and moved against the current. Critical speeds for fish lengths of 105-123cm were  $99.8 \pm 4.9$  cm/sec at a water temperature of 25-27°C. Therefore it appears that accumulation of the fish is associated with a lack of current. At this dam the single fish-pass assists the passage of only 10% of the sturgeons which approach the dam. Trusov (1970) observed that when these fish accumulate under the dam fishes at different stages of maturity all offer a steady resistance to the current. However, when the water warms to a temperature ideal for spawning, the spawners move considerable distances away from the dam in search of suitable spawning grounds. During a twenty-four hour period the fish traverse the length and width of the tailwater, depending upon the degree of illumination and those with diurnal migratory patterns move away from the bank at night, or move downstream. These rhythmic movements are also associated with the operating regime of the dam and hydroelectric power station.

Fish also move laterally along the boundaries of the transverse flows. If such flows pass along a bank, the fish will progress along the bank, *e.g.* along the sloping wall of the diverting canals of the hydroelectric dams (Kharchev, 1940; Tikhii & Viktorov, 1940; Nussenbaum, 1961; Pavlov, 1979; Malevanchik & **Nikonov**, 1984). This aspect of fish behaviour must also be considered when deciding upon the siting of fish-passes.

Although these observations of fish behaviour are of interest, they give only an approximate picture of fish distribution and movements. Appropriate methods for quantitative measurements are not yet available. Friez & Tesch (1965) tried with electro-fishing techniques, but their catches were made exclusively from near-bank situations. Similar studies using cast nets (Pavlov, 1979) were difficult to interpret because it was difficult to discriminate between areas of approach in direct currents, and areas where fish accumulated in whirlpools and stagnant waters. Also comparisons between two such areas are invalid since fish may be trapped in whirlpools for several days and catches from such sites were usually higher.

The introduction of bio-telemetry has made it possible to study fish behaviour in the operational zones of hydraulic works. It is now possible to record the movement of individual specimens, their location in the water at any time, and their speeds, daily rhythms and other characteristics, together with associated environmental parameters. Such investigations were instigated in the USSR by Poddubniy and his colleagues, working with sturgeons under the Volgogradskaya Dam (Poddubniy, 1965). Similar studies have now been carried out on many hydraulic schemes where fish-passes have been installed, or will be built, including Volgogradskiy, Saratovskiy, and the flow-divider on the Volga River; Kochetovskiy on the Don River; Fedorovskiy and Krasnodarskiy on the Kuban' River; Rizhskiy on the Daugava River and Nizhne-Tulomskiy and Verkhne-Tulomskiy on the Tuloma River.

The topography of the river bed plays an important role in determining the path traversed by bottom-dwelling fish, such as Acipenseridae. They tend to avoid flat surfaces and to follow the contours round the sides of mounds and slopes. The topography of the bottom, together with the current velocities, thus plays a significant role in determining the distribution of Acipenseridae, not only in rivers, but also in the tailwaters of dams. Where there are great variations in the bottom topography and in the hydraulic conditions of the tailwater in different years, one can see distinct changes in the paths by which fish

approach dams (Fig. 15). This complicates the choice of location for fish-passing devices, and requires the stabilisation of the bottom of the tailwater.

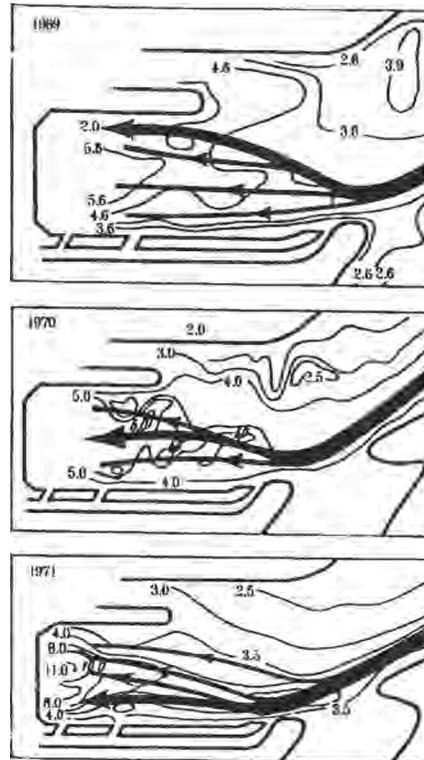

Figure 15.— Paths of movement of *Acipenser stellatus* in the tailwater zone of the Fedorovskiy hydraulic scheme, based on the telemetric data of Poddubniy *et al.*, (1978).

### 3.2.1.2 STUDIES OF FISH DISTRIBUTION USING MODELS OF HYDRAULIC SCHEMES

Difficulties have arisen in the quantitative assessment of fish distribution in the tailwaters of dams, using fishing gear and hydro-acoustic devices. The large scale use of telemetry has not yet proved possible. Therefore investigators have looked for new ways to assess the distribution and behaviour of fish in tailwaters. In particular, investigations have been carried out using mature fish and partial constructions (Kharchev, 1940; Clay, 1961; Wayne, 1961; Collins, 1966). In the 1960s Nussenbaum, Malevanchik, Pavlov and Karelin all emphasized the need to study fish behaviour, using small fish and models of prospective hydraulic projects, because it seemed that such methods would permit the determination of potential zones of fish accumulation and lines of movement. Such studies should enable prediction of the best sites for fish-passes and the numbers of these structures required. These requirements could then be included in the design stages of the respective hydraulic projects.

Studies of the behaviour of young *Alburnus alburnus*, *Blicca bjoerkna*, *Salmo gairdneri* (rainbow trout) and *Vimba vimba*, 22–60mm long, indicated patterns similar to those known for mature fish found under dams. These patterns included the displacement of the fish and their accumulation along the boundaries of the transit flow, their concentration under the dam, accumulation in whirlpools and zones of low current velocity, and the formation of 'queues' at the inlets of fish-passes. These experiments were carried out using conventional hydraulic chutes by Pavlov & Kobetz (1974); Kobetz, Shkura & Volkov (1974); Kobetz & Shkura (1975); Pavlov (1979), and on models of the tailwaters of the Volgogradskiy, Kochetovskiy and

Saratovskiy hydraulic schemes by Nussenbaum 1978 . These authors compared the results obtained from the models and small fish, with the known behaviour of large fish in nature.

Experiments using 20 species with conventional models showed that the structure of the flow influences the distribution and behaviour of different fish species in different ways (Pavlov, 1979 . Under conditions of uniform flow rheoreaction is obligatory. Once in a velocity gradient fish actively select the most suitable flow zone for their physiological state. Some species move against the current while others move to zones of sluggish or circular currents, or even begin to drift back with the current. However, the behaviour of young fish cannot be used to predict the behaviour of gravid females when conditions are right for spawning.

Ideally, the use of physical (hydraulic) models requires that all objects under investigation, including dams and fish, are to the same scale. However, this is extremely **difficult**, since either the model projects have to be very large, or the fish have to be very small - in their early larval stages. Thus when modelling fish behaviour in a flow, it is of prime importance to establish that the dynamic interactions of the model fish and real fish, with the flow, are similar. Hence a bio-hydraulic index  $F$  is used, relating the flow velocity  $V_n$  to the critical current velocity ( $V_{cr}$ ) for the fishes involved. This is defined as follows:

$$V_{cr}^m = F M$$

where:

$V_{cr}^n$  the critical speed of spawners in nature

$V_{cr}^m$  the critical speed of the 'model' fishes, and

$M$  the scale of the model.

To see if such a similarity genuinely exists, experiments were set up, in conjunction with hydraulic engineers from the Novochoerkass Institute of Land-reclamation Engineering. Young *Vimba vimba* in three size groups 22-28, 32-36 and 39-44mm were subjected to five different hydraulic regimes (Fig.4). As expected,  $V_{cr}$  increased as the size of the fish increased. For each hydraulic regime four velocity levels were examined such that  $V_{average} = 0.3V_{cr}; 0.52V_{cr}; 0.84V_{cr}$  and  $1.1V_{cr}$ . The velocities and spatial positions chosen by the schools of fish were found to be the same in these trials. Thus, the chosen criterion provides for similar behaviour in groups of fish of different size. Using  $V_n^m$  the flow velocity in natural conditions, and  $V_n^m$  as the flow velocity in the model, dynamic similarity of the interaction with the flow is achieved when:

$$\frac{V_n^m}{V_{cr}^n} = \frac{V_n^m}{V_{cr}^m} \quad \text{or} \quad \frac{V_n^m}{V} = \frac{V_{cr}^m}{V_{cr}^n}$$

Taking all this into account Shkura and co-workers carried out investigations on bio-hydraulic models of the Kochetovskiy and Fedorovskiy hydraulic schemes Shkura, 1979; Shkura & Kobetz, 1975 , obtaining good comparisons of qualitative and quantitative indices of behaviour between model and natural fish. This approach can therefore be used during the design stage of future fish-passes.

### 3.2.1.3 FISH DISTRIBUTION IN RELATION TO THE LOCATION OF FISH-PASSING DEVICES

In summarising the results obtained from natural conditions, bio-telemetry and bio-hydraulic modelling, the following generalisations of fish distribution and behaviour in the tailwaters of dams can be made:

- fish approach hydraulic schemes at the sites of highest water discharge;
- fish congregate close to the **dam**, at distances of **0-500m**, depending on the velocity of the current (the lower the velocity, the closer they approach);
- a 'search zone' is formed at the dam, in which the fish move backwards and forwards, as well as across the width of the main flow;
- the outer boundary of the search zone is located where the velocities of the flow approach the critical velocities of the fish;
- fish move across the width of the main flow, but in the presence of a current gradient they select **definite** zones;
- when current velocities exceed critical velocities, the fish redistribute and collect in stagnant zones at the boundaries of the main flow, or along the banks;
- when fish enter whirlpools they become disoriented, and may remain there for long periods;
- when fish become fatigued, they collect in stagnant zones, *e.g.* under non-operating weirs, and in this case, their distribution is determined not by the current, but by other environmental factors;
- the horizontal distribution of fish in tailwaters tends to reflect their normal horizontal distribution during their migration;
- during a 24 hour period the fish traverse the length and breadth of the tailwater. In periods of high locomotor activity they move upstream, but during periods of low activity they drift downstream, or they move to the river bank.

It therefore appears that fish-passes would be best placed in the main flow zones, as well as along the boundaries of stagnant zones, zones of reduced current, and along banks. Possible positions for fish-passing structures at hydraulic schemes are shown in *Fig.16*.

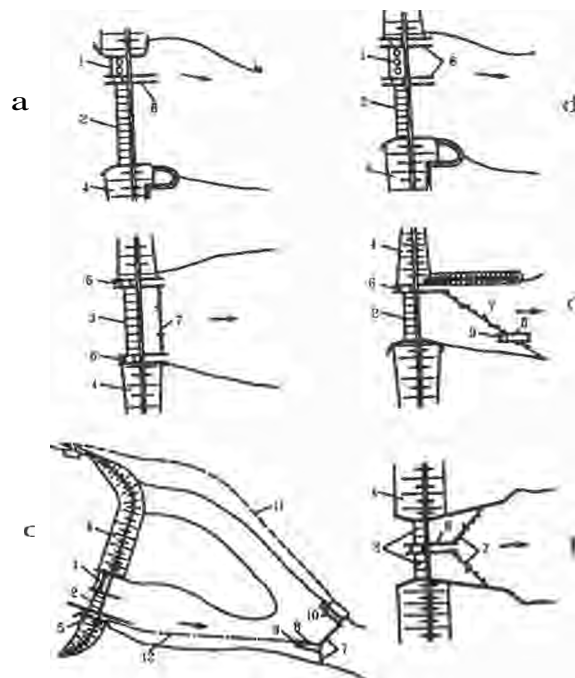

Figure 16.— Position of fish-passes in different hydraulic schemes, after Malevanchik & Nikonorov (1984): a. at common weir dam with one fish-pass, b. as above but with two fish-passes, c. at a combined type of hydraulic scheme, d. at land-reclamation project with fish-pass located near the bank, e. at tail-water of hydraulic scheme, 1. central *fish-pass* located within dam site. 1. hydro-electric plant, 2. spillway, 3. power plant building, 4. end wall, 5. navigation sluice, 6. fish-pass, 7. electrical fish barrier, 8. fish-collection barge, 9. transport vessel, 10. stationary fish-collector, 11. pathway of transport truck, 12. pathway of transport barge.

The inlet of a fish-pass must be placed outside the boundaries of the spillway apron and a little below the upper boundary of the search zone (at 2-5m according to Malevanchik & Nikonorov (1979) and at 10-15m according to Kharchev (1940). The length of the fish collecting gallery is determined in part by its location. Usually in large hydraulic schemes it is **80-100m**. When water conditions, *e.g.* velocity, turbulence and oxygen levels, prevent migrating fish from approaching a dam, then fish-passes should be located below the lower limit of influence of the hydraulic scheme.

### 3.2.2 THE ATTRACTION OF FISH TO FISH-PASSING DEVICES

#### 3.2.2.1 THE ATTRACTING FLOW

In the tailwater of a dam the outflow from a fish-pass forms its own plume which attracts migrating fish. The velocity of the attracting flow must not be greater than the current threshold velocity for the fish ( $V_{thr}$ ). This depends upon the species of fish and the length of the spawners, and lies between 4 and 25cm/sec. Laboratory experiments have shown that when the velocity of the attracting flow is increased, the number of fish which enter the experimental canal (a glass tube) also increase (Pavlov, 1979). Only when the flow velocity is close to the critical velocity for the fish does the number decrease. Tests carried out on the floating fish-pass of the Ust'Manych hydraulic scheme confirm this (*Fig.17*). Increasing the attracting flow to 70cm/sec resulted in an increase in the numbers of *Abramis brama* and *Stizostedion lucioperca* entering the device. The velocity of 70cm/sec is a little less than the critical velocity, which in migrating *Abramis brama*, for example, is 80-115cm/sec. The numbers of attracted fish declined because after two hours some fatigued fish were carried away. When the current velocity was reduced to 15cm/sec no fish were attracted because this is close to the threshold velocity.

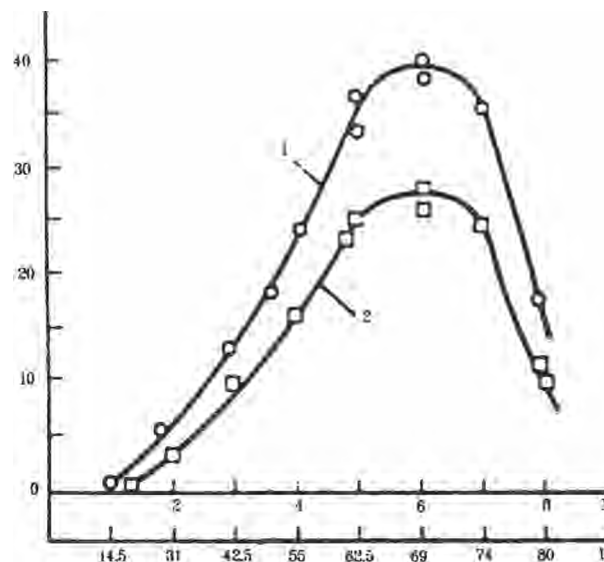

Figure 17.—The relationship between the quantity of fish entering a collecting area and the mean velocity of the attracting flow at its entry. n = number of fish/2 hour period, N = number of pumps operating, V = velocity of attracting flow in cm/sec. 1 - *Abramis brama* 2 - *Stizostedion lucioperca*

Using an attracting flow with a current velocity close to the threshold (about **20cm/sec**) was one of the main causes of the unsatisfactory operation of the fish-passing device at the Fedorovskiy hydraulic scheme, on the Kuban' River, which was constructed in 1967 for the passage of Acipenseridae. The spawners of

sturgeon have high threshold velocities, *c.* 18-25cm/sec (Pavlov, 1979), and thus no fish passed through the structure, so that eventually a new fish-pass was built. Spawning *Abramis brama*, *Cyprinus carpio* and *Stizostedion lucioperca*, have lower threshold velocities, of the order of **8-13cm/sec**, while in smaller species, *e.g.* *Rutilus rutilus* and *R.rutilus caspius*, the velocities are even lower, about 4-7cm/sec. Thus the velocities of the attracting flow must lie between the threshold velocity and a point somewhat less than the critical velocity for the species to be attracted.

Usually the attracting velocities are taken as 0.6-0.8 of the critical velocities. These are equal to 0.7-0.9m/sec for Acipenseridae (*Acipenser güldenstädti*, *A. stellatus*); 0.9-1.2m/sec for Salmonidae (*Salmo salar*, *Oncorhynchus gorbusha*, *Salmo trutta aralensis*); and **0.7-1.0m/sec** for the semi-anadromous fish (*Abramis brama*, *Chalcalburnus chalcoides*, *Cyprinus carpio*, *Clupea harengus*, *Pelecus cultratus*, *Stizostedion lucioperca* and *Vimba vimba*) according to Malevanchik & Nikonorov 1984. In most cases these values were equal to **0.7-1.0m/sec** at the operational devices.

In practice, the average velocities of the attracting flow may be even higher than the critical velocities. This is related to the irregular distribution of the velocities over the cross sectional area of the fish collection gallery, and in the zone of attraction in the tailwater of the hydraulic scheme. In cases of higher velocities the migrating fish begin to move to the near-wall layer near the bottom, or **find** shelter close to the entrance of the gallery. According to Shkura 1979 the average velocity of the attracting flow in the Kochetovskiy navigation sluice can be increased for semi-anadromous fish up to 1.44m/sec, and for *Acipenser* spp., which are benthic, up to 1.95m/sec, *i.e.* they may exceed the critical velocities. However, the velocities of the water layer in which the fish actually move are likely to be significantly lower than this, and are probably not greatly different from the critical velocities, as indicated by hydrodynamic and telemetric experiments. The fish collection barge, which has flat walls along which boundary flow is of lowered velocity, approximates closely to the ideal situation when using a glass tube in experiments.

There are two ways of increasing the area of attraction. Firstly, the velocity of the attracting flow can be varied. Initially the discharge flow velocity is increased to several times the critical velocity to ensure a large area of attraction, then it is decreased gradually to provide suitable conditions for fish to enter the mouth of the fish-pass. The second method is to create additional current at the inlet to the fish-pass. The current velocity in the fish-pass itself should approximate the cruising speed of the fish (see Fig. 3). Maximum velocities are created at the inlet, but as the fish spend only a short time there (1-20 minutes) they do not become fatigued. A more complete knowledge of swimming performance ( $T_v$ ) is required for calculating attracting flow velocities and periods of attraction. For example, for *Acipenser güldenstädti* at a velocity of 0.95 m/sec,  $T_{0.95} = 40\text{min}$ ; for *Acipenser stellatus*  $T_{0.95} = 30\text{min}$  and  $T_{1.1} = 10\text{min}$ ; for *Acipenser ruthenus*  $T_{0.82} = 30\text{min}$ ; for *Rutilus rutilus caspius*  $T_{0.46} = 55\text{min}$ ,  $T_{0.60} = 25\text{min}$  and  $T_{0.78} = 2\text{min}$ . For other fish, see Fig.18. These data suggest that not only does swimming performance vary between fish of different species but that it is also significantly affected by water temperature and the sex of the fish (Pavlov *et al.*, 1984). Swimming performance decreases sharply just before spawning.

Thus it is necessary to provide a wide and controllable range of attracting velocities at the fish-passes. For this purpose, current controlling mechanisms are available such as flat gates with water outlets, **spillways** with apron wells, diverting bottom and lateral galleries, and variable throughput controllers of a radial type. There are methods for calculating the flow characteristics generated by these devices, and for determining the hydraulic parameters of the attracting plume produced (Barekyan, 1980, 1981; Mikheev *et al.*, 1982; Malevanchik & Nikonorov, 1984; Barekyan & Lupandin, 1985; Barekyan & Skorobogatov, 1985). These systems are incorporated in most fish passes, either operating or under construction, in the USSR.

The velocity of the plume of the attracting flow should differ from that of the main flow by a value which is no less than the threshold value. If the main flow velocity ( $V_s$ ) is less than the critical velocity, then the

attracting flow velocity ( $V_{sur}$ ) must exceed  $V_n$  by the value of the threshold velocity. If the main flow velocity ( $V_n$ ) is higher than the critical velocity, then  $V_{sur}$  must be less than  $V_n$  by the value of the threshold value. According to Malevanchik & Nikonorov (1984) the difference ( $AV$ ) between the velocities of the plume and the adjacent flow should be **0.15-0.2m/sec**, i.e. close to the threshold velocity for most migrating fish. Smaller differences would not be practicable because pulsation of the flow in the tailwater would obscure them.

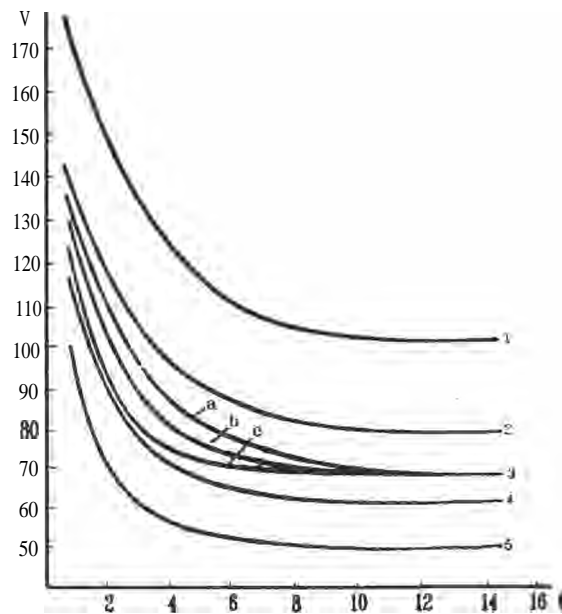

Figure 18.—The relative swimming performances of different fish: 1. *Clupea harengus*, males & females of mean length 27.2cm; temp. = 11.9°C;  $V = 163 t^{-1} + 97$ . 2. *Clupea harengus*, males & females of mean length 27.7cm; temp. = 13.5°C;  $V = 112 t^{-1} + 80$ . 3. *Chalcalburnus chakoides*, a. females, 20.7cm mean length;  $V = 116 t^{-1} + 69$ , b. males, 20.7cm mean length;  $V = 81 t^{-1} + 72$ , c. males, 17.3cm mean length;  $V = 53 t^{-1} + 74$ . 4. *Vimba vimba*, males & females of mean length 30.2cm;  $V = 62 t^{-1} + 67$ . 5. *Abramis brama*, males of mean length 35.5cm;  $V = 52 t^{-1} + 56$ .

Umanets and Bykov (1982) investigated the influence of the discharge flows ( $V_1$  and  $V_2$ ) adjacent to the sides of the collection galleries, from which the attracting flow is created, at the Krasnodarskiy, Kochetovskiy and Nikolaevskiy schemes. They found an optimum attracting velocity ( $V_{sur}^{op}$ ) for semi-anadromous fish:

$$= 0.46 (V_1 + V_2) + 035 \text{ m/sec}$$

Applying this relationship, and creating non-uniform discharges from the spillways along the sides of the fish passes, they increased the numbers of fish entering these systems by factors of 1.8, 2.2 and 1.6 respectively in the different schemes.

The empirical values ( $AV = 0.15-0.35$ ) are of practical significance for calculating velocities at the inlet to the fish collectors, but they do not define the flow gradients actually experienced by the fish around the attracting zone. Moreover, as the distance from the fish-pass increases, the value  $AV$  along the plume length decreases. Investigations on the behaviour of young *Rutilus rutilus*, used as model fish, indicate that the development of paths of movement involve such hydraulic features of the flow as the direction and the velocity of the current,  $V$ , the turbulence intensity,  $K = d/V$  (where  $d$  is the standard deviation of pulse velocity from the average, in time), and the transverse gradient  $J = dv/dy$ . The data obtained were used to devise a method of forecasting the likelihood of fish entering fish-passes (Skorobogatov *et al.*, 1983).

In summary, the efficiency of fish attraction at the approach to fish-passes is linked both to the transverse flow gradient present and the relative velocities of the attracting flow and main flow, and therefore on the arrangement of the structures of the hydraulic projects.

### 3.2.2.2 HYDRAULIC SCHEMES OF FISH ATTRACTION AND THE ARRANGEMENT OF HYDRAULIC WORKS

A powerful means of controlling fish behaviour in tailwaters is to vary current velocities. If the discharge velocity exceeds the critical velocity in certain sectors, fish will be prevented from accumulating in them, while by using lower velocities, they can be encouraged to accumulate around the mouths of fish passes. Further, migrating fish tend to avoid areas where the current velocity is maintained below, or close to, the threshold velocity. Taking these facts into consideration three common tailwater types may be recognised:

**1. Water discharge occurs uniformly along the entire front of the hydraulic structure; and the flow velocity exceeds critical velocity.** In this case fish-passes may be located along the sides of the hydraulic structure, *e.g.* along the sides of the hydroelectric power station or of the **spillway**.

**2. Water discharge occurs uniformly along the entire front of the structure, and flow velocities are below critical velocities.** Fish-passes may be placed anywhere along this front, but a central position is preferable.

**3. Water discharge occurs non-uniformly, or there is a stagnant zone under the weir.** Here, it is preferable to place the fish-passes along the border of the main flow, or along the bank, provided it is not close to a weir which is inoperative during fish migrations.

Exceptionally, with type 1 tailwaters there may be a case for building a central fish-pass, if during the initial period of the attraction process, discharge velocity is decreased significantly below normal. In this case whirlpools form in front of the fish-passes and may assist in fish accumulation. Thereafter, increasing the discharge velocity at the end of the attraction cycle will dissipate the whirlpools and ensure that the fish enter the collector. With types 2 and 3, a regime may be applied where, during the initial period of attraction, discharge velocities exceed critical velocities, but if then they are decreased gradually towards the end of the attraction cycle, fish are effectively 'pulled' into the collector.

As a rule, however, the velocity of the attracting flow in the fish movement layer (not the average velocity of the whole flow) must be less than the critical velocity, and should correspond to the maximum speeds at which the fish swim. However, with type 1 tailwaters this velocity must lie within the average range of these speeds, and with types 2 and 3 they must approach the upper limit during the period of attraction. *Fig. 19* illustrates the arrangement of a number of fish-passes.

The width of the weir is of great significance in determining the number of fish-passes required. In bio-hydraulic experiments carried out on young fish in a chute 4.6 x 12m, Ivanov & Nebozhenko (1984) showed that the efficiency of fish attraction decreases as the length of the weir increases. Narrowing the weir improves conditions for the control of migrating fish behaviour, and increases the concentration in the zone of search in front of the fish-pass. When the amount of water discharged through the demountable dam at the Kochetovskiy hydraulic project was increased by 2.5 times, then the number of fish entering the fish-pass doubled. It seems that a single fish-pass ensures effective fish attraction from a weir width of 100-200m. When designing hydraulic projects the number of fish-passes must depend upon the number of fish collecting sites, the pattern of the tailwater current and on the degree of control which can be exercised over the fish-pass.

To ensure maximum fish attraction water discharge from the dam must be co-ordinated with the operation of the fish-passes. During times of intensive migration water discharges should be manipulated



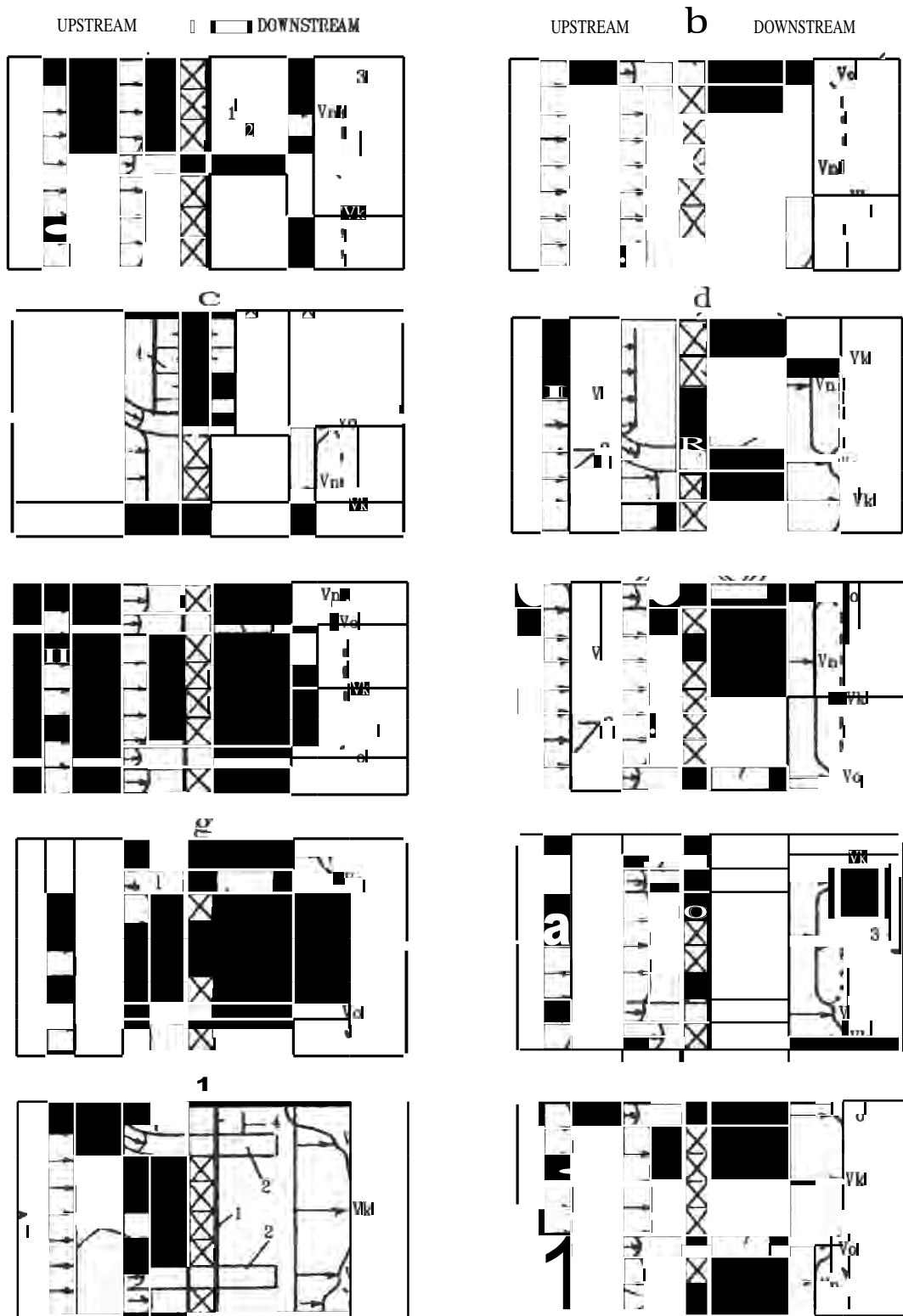

Figure 19. — Velocity profiles in a range of structures: 1. overflow, 2. fish-pass, 3. velocity curves, 4. man wall.  
 a. uniform velocity,  $V_n < V_{cr}$ , central fish pass. b. uniform velocity,  $V_n < V_{cr}$ , side fish pass. c. non-uniform velocity, angled pass adjacent to wall. d. non-uniform velocity, angled fish pass. e. uniform velocity, double passes. f. uniform velocity, passes at each side. g. uniform velocity,  $V_n > V_{II}$ , double passes. h. uniform velocity,  $V_a > V_{II}$ , double passes. i. non-uniform velocity, angled and straight passes. j. non-uniform velocity, side and off-centre fish pass.  $V_0$  = fish pass entrance velocity,  $V_n$  = main discharge velocity in normal flow,  $V_0$  = discharge velocity during attraction.

to optimise the passage of the fish by creating favourable currents in the tailwater. This has been demonstrated, for example, where two adjacent discharge units exercise a positive influence over the entry of fish into the Volgogradskiy fish-lift. When, in 1962, the unit nearest to the fish-lift was under repair, the number of Acipenseridae passing through the fish-lift was 2.5 times lower than it was for the same period in 1961, even though there were more fish in the tailwater. When these units are not operating, the boundary flow, in which the fish normally move, is disrupted, and the fish are attracted to other units which are operating, rather than to the fish-lift. The operation of units close to fish-passes provides a plume of water which reaches the migrating sturgeon. They also encounter strong flows ( $V_{\alpha} = 1.5-2.0$ ) from the hydroelectric power station ( $V = 1.7-2.25\text{m/sec}$ ) which lead them towards the flow from the fish-lift ( $0.6-0.8\text{m/sec}$ ). Similar observations have been made at other hydraulic projects such as Nyzhne-Tulomskiy and Saratovskiy (Pavlov, 1979; Barekyan & Skorobogatov, 1982).

In order for migrating fish to be attracted, the main and attracting flows have to be carefully aligned. Thus, the attracting flow must be parallel to, or at an angle not exceeding  $30^{\circ}$  to the main flow. A greater angle, as observed during ebb and flow phenomena on the Nizhne-Tulomskiy fishway, effectively extinguishes the attracting plume and fish cease to be attracted.

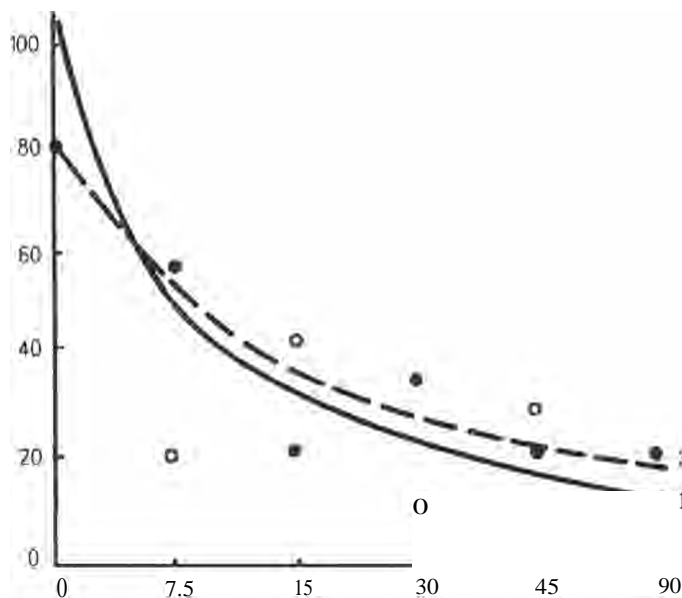

Figure 20.— Influence of the angle ( $\alpha$ ) of the ramp on the efficiency, expressed as a %, of fish entry to the fish collector. Data from tests on 48 *Rutilus rutilus* and 98 *Acipenser stellatus*: 1. *Acipenser stellatus*, 60-70mm long.  $V_{\alpha} = 40\text{cm/sec}$ ;  $V_{\text{attr}} = 0.8V_{\alpha}$ , 2. *Rutilus rutilus*, 32mm long.  $V_{\alpha} = 32\text{cm/sec}$ ;  $V_{\text{attr}} = 0.8V_{\alpha}$ .

It is also necessary that the actual layer of water, in which the fish travel, combines with the attracting layer. The importance of this has been demonstrated when using floating fish-passes, where a ramp is used between the collector and the bed. At the Ust'Manych hydraulic scheme the ramp was set at an angle of  $8-9^{\circ}$  relative to the river bottom and both surface swimmers (*Abramis brama*, *Clupea harengus* and *Pelecus cultratus*) and near bottom migrants (*Stizostedion lucioperca*) were attracted into the fish collector. By contrast, at the Fedorovskiy and Kochetovskiy hydraulic schemes, where the angle is about  $16^{\circ}$ , only surface swimmers (*Abramis brama*, *Clupea harengus*, and *Pelecus cultratus*) enter the fish-pass, and representatives of the second group (*Acipenser stellatus*, *Acipenser guldensüdti*, *Acipenser ruthenus*, *Stizostedion lucioperca* and *Vimba vimba*) are absent. Subsequent work, carried out in association with hydraulic

engineers of the *Kalinin Polytechnical Institute*, dealt specifically with small fish which move in the near-bottom layers, e.g. *Acipenser ruthenus* and *Rutilus rutilus*. This work showed that the efficiency with which these species are attracted to a collector decreases abruptly as the angle of approach to the collector increases (Fig.20). At angles of 8-12° a zone with zero current velocities is formed; at wider angles a whirlpool is created which disorients the fish. However, trials with perforated ramps at an angle of 7.5 led to a marked increase in efficiency. At present, the best solution seems to be the use of a perforated ('chinked') ramps with a jet-guiding wing' in the front of the collector. This ensures that bottom swimming migrants enter the collectors (Barekyan, 1981; Malevanchik & Nikonorov, 1984).

The daily rhythm in the spawning activities of fish is reflected in an equivalent rhythm in their entering fish-passes (Fig.21). This has to be taken into account when deciding the operational regime of a fish-pass and in determining different configurations for the attracting flow over a 24 hour period. If the device is intended to pass only the nocturnal migrants it can be switched off during the day and *vice versa*. When migration is at its height, the operation of all spillways must be controlled so that optimal conditions are created for the entry of migrants to the fish-pass.

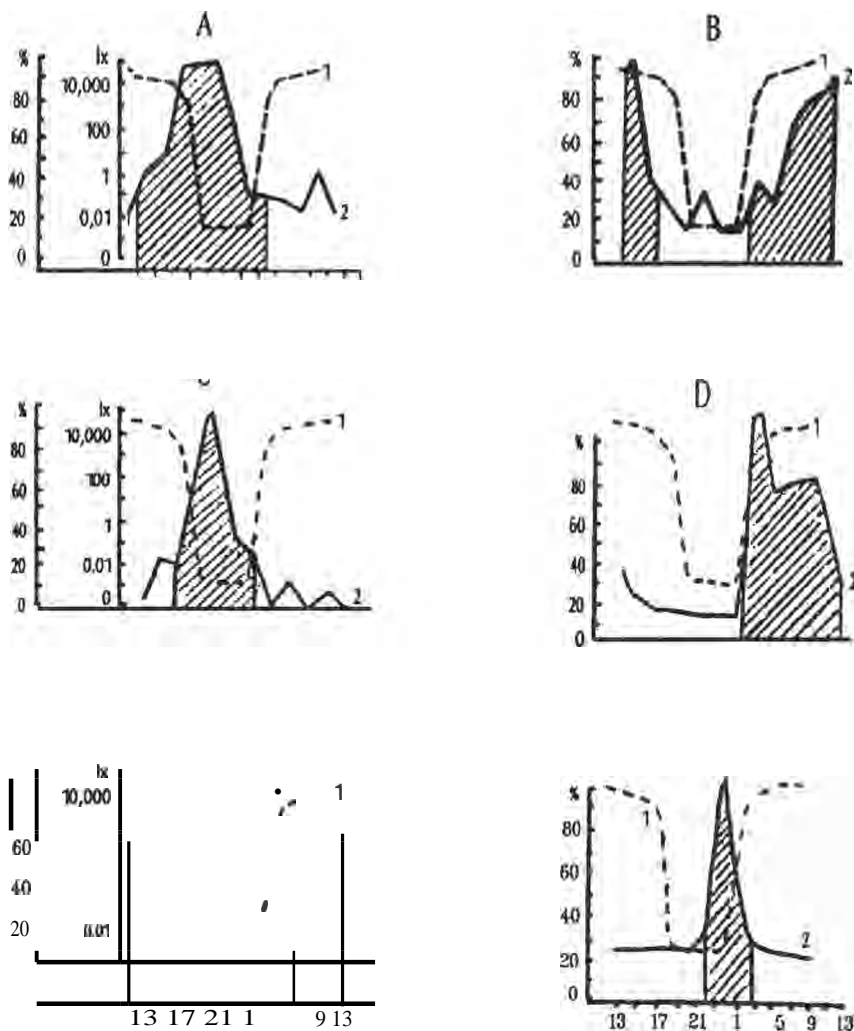

Figure 21.— The daily rhythm of fish entry to the Volgogradskiy fish-lift (June-August 1965) and the floating fish pass during trials below the dams at the Ust'-Manychskiy and Kochetovskiy hydraulic schemes (May 1971): A. *Acipenser güldenstädti*, B. *Abramis brama*, C. *Pekcus cultratus*, D. *Clupea harengus*, E. *Clupea harengus*, F. *Stizostedion lucioperca*. The optimum period for entry is cross-hatched.

## 3.2.2.3 BLOCKING AND GUIDING DEVICES

Blocking and guiding devices are used to increase the efficiency of attracting fish into fish-passing structures. The former block fish movement on definite parts of the spillway front, the latter orientate fishes in the flow. Investigations by several authors, *e.g.* **Kharchev** (1940) and Schiemenz (1957), confirm the value of placing these devices at an acute angle to the axis of the water flow. The collector is then placed in the apex of the angle.

Blocking devices are either mechanical or electrical. Mechanical systems are either metallic screens or pivoted barriers. These were used for the first time on the Volkhovskiy and Kuybyshevskiy hydraulic schemes (**Kharchev**, 1940; Tikhii & Viktorov, 1940). A floating mechanical device has been designed for the Rizhskiy scheme which comprises **10m** long sections which can be deflected by the water flow if they become clogged or obstructed. Once deflected, the obstructing materials are swept off, or over, the device by the current (*Fig.22*). These devices can easily be raised to the surface to be cleaned, but, despite this, their application is far from straightforward and they are not yet in regular use.

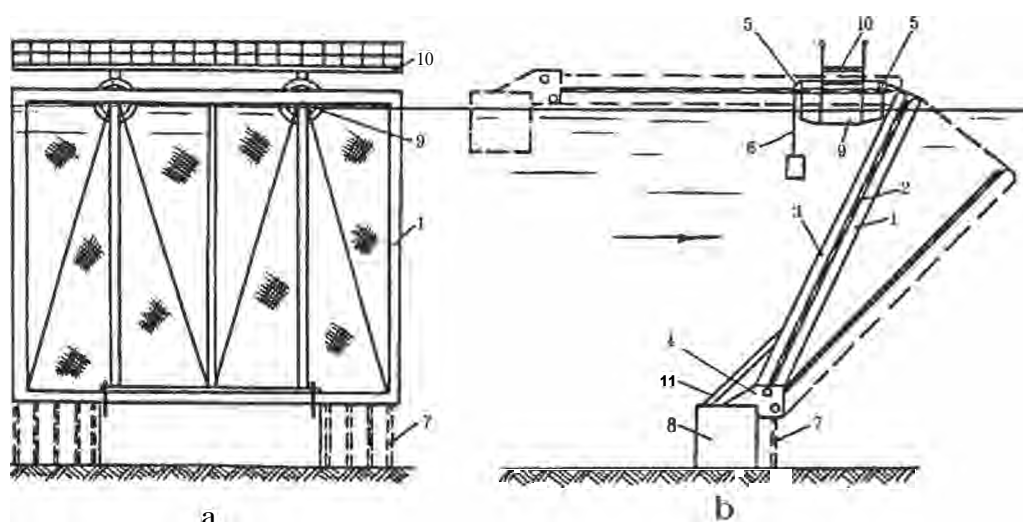

Figure 22.— A mechanical guiding device: a. front elevation, b. section: after Malevanchik & Nikonorov (1984). 1. frame, 2. fish-protection screen (FPL), 3. tube of pontoon, 4. hinge connection, 5. block system, 6. counterbalance of FPL, 7. chains, 8. bottom pontoon, 9. support pontoon, 10. access bridge, 11. hose for filling pontoon with water or air.

Electrical blocking devices are widely used outside the Soviet Union (Clay, 1961; Vibert, 1967) and a device known as ERZU-1 is used in the USSR (Strakhov & Nussenbaum, 1959). It was tested on the Tsimlyanskiy and Ust'-Manychskiy schemes and is now in use on the Rizhskiy scheme. A problem with the successful operation of these devices lies in selecting an appropriate potential difference, since this varies for different fish species and sizes. The threshold stimulus for small fish can be critical for large fish, and can stun them. The design of these devices must ensure a threshold distance of **5-10m**, and the difference between the threshold distance and the critical distance, at which fish are stunned, is generally 5-7m (Malevanchik & Nikonorov, 1984). These devices may be used to prohibit the access of fish to specific sites on a hydraulic scheme.

Different structures are used as fish-guiding devices *e.g.* 'tactile ways', ditches, bottom rapids, and ledges placed obliquely from bank to fish-pass. Tactile ways consist of large stones laid on the bottom to facilitate orientation of bottom fish. Ditches are hollows cut into the bottom to guide Acipenseridae, as they respond strongly to changes in relief (Poddubniy, 1978). Bottom rapids and ledges are specially constructed prominences on the bottom, and are in wide use in hydro-engineering practice, as devices to

manage deposits at water-intake heads. Their use as fish-guides arises because definite hydraulic conditions arise behind the rapids they create, providing selectable currents in the zone of search. Such currents can be good guides for near-bottom fish and have been investigated under laboratory conditions for a number of young fish including Acipenseridae (Shkura, 1979; Sukalo, 1982).

### 3.2.3 FISH BEHAVIOUR AND OPTIMISATION OF FISH-PASS PERFORMANCE

#### 3.2.3.1 FISH BEHAVIOUR IN FISH-PASSES AND COLLECTORS

Fish behaviour in fish-passes is largely determined by the structure of the pass. The direction and velocity of the current changes along the length of a fish-pass and consequently there is a change in the speed and direction of fish movement relative to the sides of the fish-pass. The low current velocities (c.0.2-0.5m/sec) which occur in the pool chambers of the fishway correspond to the cruising speeds of the fish, while the high velocities in the embryo areas of the channels (1-2.3m/sec) correspond to burst speeds. Thus the fish move from chamber to chamber by virtue of burst speed swimming. Fish which have to ascend waterfalls during their natural migrations, e.g. Salmonidae, are most adept at moving in this way. Flick (1968) was able to show that, when leaping falls, these fish make use of the energy of the stagnant wave beneath the waterfall. Other fish can also ascend fish-passes, especially if the connecting channels are provided with special openings for bottom-swimmers. Thus, *Abramis brama*, *Anguilla anguilla*, *Rutilus rutilus* and *Vimba vimba*, and many other species migrate up the Kegumskiy fish-pass, although conditions for their passage are probably not optimal. During their transit of this fishway *Vimba vimba* lose 13-15% of their fat, and there is some resorption of the reproductive organs in females (Sakun, 1957; Malikova, 1961). Reconstruction of this particular fish-pass is now planned in an attempt to better facilitate the passage of these species.

Transit is particularly difficult through fish-passes where whirlpools form in the pool chambers. This is because fish lose their orientation and may be delayed in a chamber for several days. This in turn may fatigue them to such a degree that they are unable to cope with the currents, so that eventually they drift back downstream (Pavlov, 1979). In fish-passes, as in rivers, fish manifest alternate phases of active forward movement and backward drift. These alternations are most often seen in the lower chambers, where they frequently result in fish drifting back down to the river. This drift is connected not only with fatigue, but also, and importantly, to a loss of the conditions required for orientation. Clearly, illuminating the chambers, and providing visual cues in them, will assist the passage of migrants up passes.

The behaviour of fish in passes, and the optimization of environmental parameters therein, have been well studied, e.g. Collins & Elling (1960), Clay (1961) and Ebel (1985). Here therefore, only the behaviour of fish in the collectors of lifts and sluices is dealt with in any detail. In fish-collecting chambers, current direction and velocity are generally constant along the length of the device. Accordingly, since fish movement is oriented by the current, fish move parallel to the walls of the chamber. Currents in the collector of the Volgogradskiy fish-lift are 0.5m/sec at the bottom, but 0.7-0.8m/sec in the water column, and underwater observations suggest that the dynamics of fish distribution are analogous to those of the corresponding species in the river (Pavlov, 1979). *Abramis brama*, *Aspius aspius*, *Clupea harengus* and *Pelecus cultratus* were observed mainly during the daylight and only in the water column, while *Acipenser guldensstädti*, *A. stellatus* and *Siluris glanis* were observed only during darkness and 10-15cm from the bottom. Small fish, such as *Leuciscus idus* and *Perca fluviatilis* move close to the chute walls.

The distribution of fish along a pass is uneven since they accumulate in the intake. Because many fail to reach the sluice chamber, the use of a crowding screen is valuable. This screen is lowered at the end of the lower part of the chute, driving the fish before it towards the lift. Its operation is quite satisfactory; the fish do not get trapped between it and the bottom. Only when the lock gate is closed and the current ceases, do bottom fish rise some 2-3m into the water column, and other fish escape from the chamber under the

screen. Along the lower edge of the screen of the Volgogradskiy fish-lift, there are hanging chains to frighten the fish, but they prove effective only in the presence of a current. Thus, on later constructions these chains have been replaced by rubber aprons which are a barrier to the fish even when the current stops. The value of the crowding screen has been proved in trials Nussenbaum, 1967 ; without screens the number of fish entering the lift was insignificant.

A coefficient of irregularity ( $K_{irr}$ ) is used to estimate the velocity distribution across a section of the fish-collector. This coefficient is calculated as the ratio of the maximum velocity to the average velocity over the given section. Hydraulic engineers seek to ensure that  $K_r$  is close to 1.2; this being considered suitable for fish entry and retention in the collector. However, according to Barekyan & Skorobogatov 1982 , where  $K_{irr} = 1.32$  at the Saratovskiy fish-lift, fish concentration is greater in the chute head, and Lazarev & Schmidt 1984 consider that high irregularity ( $K_{irr} = 2.3$  in the left hand fish collector of the Volgogradskiy lift does not significantly reduce the number of fish entering it. The latter authors obtained similar results from experiments conducted on the Kochetovskiy fish-pass. Here, at a maximum value of  $K_{irr} = 1.62$ , *Pelecus cultratus* numbers were 1.6 times higher than when  $K_{irr} = 1.2$ .

Turbulence affects both the critical and threshold current velocities for young fish. As turbulence increases, so  $V_{cr}$  and  $V_{thr}$  decrease. When turbulence changes, so too does fish distribution and behaviour (Pavlov *et al.*, 1982, 1982a .

Just as they do in rivers and passes, fish have drift phases in collectors, at which times they tend to drift back downstream Shkura, 1979 . This phenomenon is primarily determined by the hydraulic regime, i.e. by the velocity and turbulence of the current, and secondarily by the ability of the fish to orient themselves under these conditions. Experiments on young fish, and mature fish of small species, have shown (Pavlov, 1979 that the number of fish carried backwards increases sharply as current velocities approach  $V_{cr}$ . For this reason flow velocities in collectors are fixed 20-30% below critical ones, and this ensures retention of fish in the fish-pass when the lock gates are closed. When current speeds approach  $V_{cr}$ , fish begin to move into the boundary layers along the walls and bottoms of chutes.

Lockage times on functioning fish-passes are usually of 2 hours duration. Increasing the time that fish are in a fish pass is undesirable since it leads to greater fatigue and consequent increases in the numbers drifting downwards. The time it takes to attract a fish into a fish-pass must not exceed the duration of the fish's swimming ability at the velocity of the attracting flow. The current velocity in the collector can be close to the critical velocity but it must never exceed it. Optimum attracting velocities for a number of species, determined by Shkura and co-workers Shkura, 1979 , which apparently exceed the critical ones, only reflect irregularities in chutes and the approaches to chutes, and at these velocities fish move to the boundary layers of the flow, i.e. adjacent to the walls and bottom. Any recommendation to increase attracting velocities in collectors must be supported by data concerning not only the number of fish entering the devices, but also the physiological condition of those that enter. This may be determined by the relative concentration of lactate in their blood (Barker & Black, 1959; Collins *et al.*, 1962; Weaver, 1962, 1965 . At increased speed the fish are able to enter the collector but their level of fatigue is very high, so much so that it almost certainly increases the phenomenon of drift after the fish have been released in the reservoir. It would probably be advantageous to create regions of decreased current velocity, possibly whirlpools, in fish-collectors, since they would assist collection and decrease the degree of fatigue of the fish, even if high flow velocities are otherwise used.

Current velocity at the final stage of attraction is important. Decreasing the velocity for periods of just 1-2 minutes attracted many weak swimmers into the fish-collector on the Kochetovskiy fish-pass Shkura, 1979 . Optimal fish-passing depends upon the continual entry of fish to the pass. This may be achieved by building two collecting chutes which operate alternately (as at the Volgogradskiy fish-lift), or by the use of special gates which ensure attraction, even when water discharge is lowered while locks are closed.

Another way of maintaining continual attraction into a fish-pass with a single chute, is to introduce a separate supply of water into the collector through a guiding channel. Such channels have been proposed for the sluices of the Tikhovskiy and Bagaevskiy hydraulic schemes, on the Kuban' and Don Rivers respectively.

### 3.23.2 CONDITIONS FOR FISH RELEASE AND THEIR ONWARD MIGRATION

Fish lockage, counting, and release into a reservoir, are the final stages of the fish passing process. Telemetric observations have shown that from reservoirs fish continue their migrations to their spawning grounds. In Acipenseridae the lines of migration lie on the bottom or along steep banks, along the contours of slopes but avoiding areas of low relief. Observations near Balakovo before and after the construction of the Saratovskiy scheme, revealed that Acipenseridae moved upstream in the reservoir by the same routes as they used before impoundment. Thus its behavioural stereotype had not changed (Poddubniy et al., 1978).

The most difficult area in the reservoir for migrating fish to negotiate is the immediate release zone if it is near the top of the **spillways**. In this situation many fish pass back down the spillways to the tailwater. The length of the head channel is therefore determined by considering the conditions required to prevent the backward drift of fish that have successfully reached the reservoir. At the Volgogradskiy fish-lift it is 95m, at Kochetovskiy it is 43m and at Nikolaevskiy, 11.5m. However, the distances from the mouths of the head channels to the dams are 65, 46 and 44m respectively (Shkura, 1979). In accordance with existing recommendations, the outlet orifices must be situated in the reservoir, where flow velocities do not exceed **0.4m/sec** (Shkura, 1979; Malevanchik & Nikonorov, 1984). The complex hydraulics of the release zone, with its abrupt increase in transverse current gradients, and the possible approach of the local current velocity to  $V_{cr}$ , lead to disorientation. It seems that to improve matters, it will be advantageous to reduce the time that the fish spend on the fish retention grid in the transport container, and to release them in a place from which there is a smooth increase in current velocities upstream. This may be achieved by lengthening head chutes, selecting their shapes carefully, constructing special separating walls in the reservoir to isolate the release zone from that under the influence of the spillways, and by adjusting water discharges via the spillways during the maximum periods of fish migration.

## 4. STRUCTURES AND MEASURES EMPLOYED TO ENSURE THE DOWNSTREAM MIGRATION OF YOUNG FISH

Engineers have designed a large number of fish-protecting devices over the years and most reviews of fish protection *e.g.* Tikhij & Viktorov, 1940; Kharchev, 1940; Clay, 1961; Burns 1966; and Bolshov, 1967, provide descriptions of several of the structures used. However, most of the developmental work to date has been carried out by trial and error, and no structure yet satisfies the requirements completely. Empirical approaches to fish protection cannot define the precise conditions under which a given device will operate, nor the range of hydraulic and other parameters permissible for each device. In future this should change as the design of fish-protecting devices will increasingly be based on biological knowledge so that the real 'demands' of the fish are met.

The biological foundations of fish protection should encompass a full knowledge of fish behaviour, but particularly knowledge of behaviour in water flows, such as orientation and swimming performance, vertical and horizontal distribution, responses to external stimuli, and the probability of entering hydraulic intake devices during downstream migrations. The development of fish protecting devices must take into account the ecology and behaviour of each species under protection. This review is largely based on information published by Pavlov & Pakhorukov (1973, 1983).

### 4.1 PROBLEMS WITH WATER INTAKE DEVICES

#### 4.1.1 SEASONAL DYNAMICS OF FISH ENTRAPMENT BY WATER INTAKES

The problem of fish entering water intakes is very seasonal and in some systems 90-95% of the total annual entrapment occurs in one or two summer months, indeed with individual species the peak may last for only a few days. Thus in the southern Ukraine 65-91% of *all Abramis brama*, *Blicca bjoerkna* and *Alburnus alburnus* larvae enter water intakes over a period of just 3-8 days (Filchagov, 1980; Mussaenko *et al.*, 1982). However, at many hydroelectric and thermal power stations, where water is abstracted from depths of 10-15m, fish tend to be taken in all year round and significant numbers enter the abstracting devices in winter. At a number of reservoirs, including Kapchagayskoye, Ivan'kovskoye and **Sheksninskoye**, there are peaks of entrapment in the spring (late March-early April), summer, and winter (November-January) (Pavlov *et al.* 1981, 1984, 1985, 1986; Pavlov, 1986). At these times the youngest fish of the older age groups are removed. Some idea of the effect that the depth of the water intakes below the surface has on the removal of fish during their downstream migrations is given in *Fig.23*.

The seasonal variations in the numbers of fish entering water intakes reflect primarily the concentration of young fish in the vicinity of the intakes, and these in turn are correlated with the spawning seasons. Most species of fish in the USSR spawn in spring, which accounts for the maximum intake of larvae during the spring-summer period when the fry and young fish are drifting downstream. Thus it is important to know the times of migrations along each waterway. In the delta of the Volga River, the concentration of juveniles in the current increases a hundredfold during July and September (Pavlov, 1979). Having said this however, it must be emphasized that the intensity of entrapment is determined not so much by the concentration of fish in the water flow as a whole, but more by the congregation of fish in the immediate vicinities of water intakes.

The degree to which a species reacts to current at a given time of the year influences the numbers entering intakes. During late spring and summer the number of young without reaction to current is high. This is because they are under conditions of low illumination and low water transparency, and because in



general, they are slow swimmers. By late summer-early autumn these same fish are large, better swimmers and their reaction to current is less closely tied to visual cues. This change in behaviour reduces the numbers entering the intake devices. During late autumn-winter the fish can orientate just as well as in the summer, but low temperatures impair their swimming ability and in consequence they are less able to resist being drawn into the intakes.

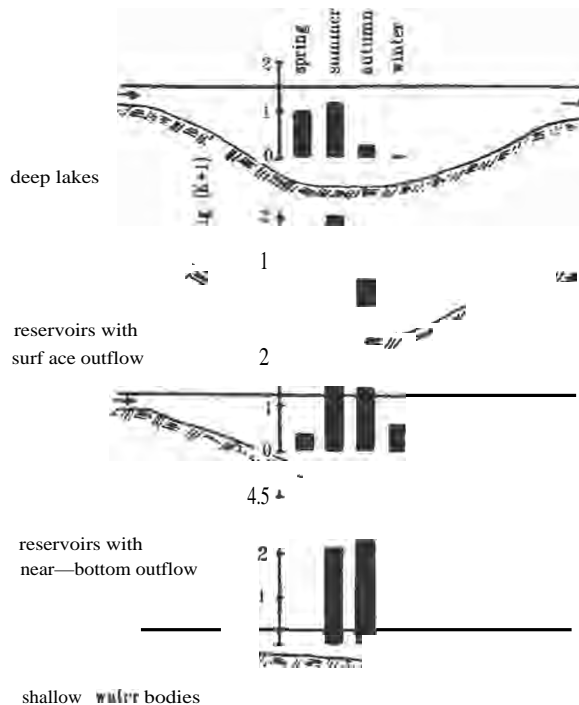

Figure 23.— Seasonal concentrations ( $K$ ) of migrating fish, in relation to outflow characteristics: arrows = outflow currents, cross hatching = solid constructions.

#### 4.1.2 THE DAILY DYNAMICS OF ENTRAPMENT BY WATER INTAKES

Over a twenty-four hour period the major period of entrapment occurs in the dark, usually between 9 p.m. and 4 a.m. The larger the fish, the later they enter the intakes, and the less frequently they are trapped compared with small specimens (Pavlov, 1966, 1970, 1979). In relatively transparent water 60-97% of young fish enter intakes during the hours of darkness (*Fig. 24*) (Demchenko, 1973; Ozinkovskaya *et al.*, 1974; Verzin & Glamazda, 1975; Khamidov, 1975; Glamazda & Glazunov, 1976; Verzin, 1978; Izvol'skiy & Ersler, 1978; Koval, 1978; Koval *et al.*, 1979; Filchagov, 1980). In turbid water bodies this peak of entrapment during darkness is usually absent.

#### 4.1.3 OTHER PATTERNS OF FISH ENTRAPMENT BY WATER INTAKES

Observations in the lower Volga River and in the Volgogradskoye Reservoir have shown that pumping stations which draw water from shallows along bays and river sides produce more damage than ones which draw water from sites more distant from the banks, or at greater depths (Pavlov, 1966). For example, in June 1965, during each 24 hour period, some 200 000 young fish entered the Olinskaya irrigation system on the Volga River delta. When the intake was moved from the river to a shallow bay (July 1970) the numbers entering the irrigation system increased, with maximum daily intakes of 3 million specimens.

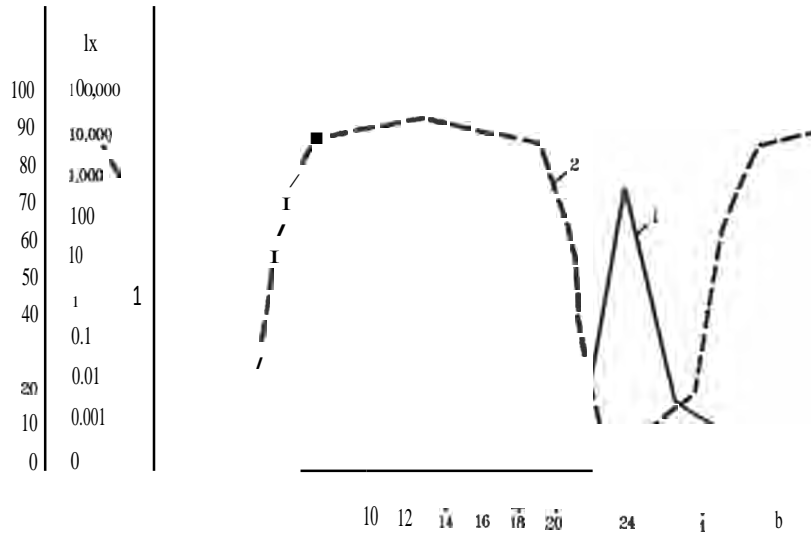

Figure 24.— The daily rhythm of young fish entering the pumping station intakes at the Kizan' fish-rearing farm in July 1964:  
1. numbers of fish entering the water-intakes, 2. light intensity.

The location of water-intake heads is very important when water is being taken from a reservoir. Thus Filchagov (1980) noted that *Rutilus rutilus* were drawn into a near bank device on the Severo-Krymskiy channel at a rate of 2313 specimens/m<sup>3</sup>/sec, while only 390 specimens/m<sup>3</sup>/sec were drawn into a deep water intake. It has been established that both the above water and underwater parts of water-intake heads, the structures of floating pump stations, and the approach channels of water-intake devices, all exert an influence on fish behaviour and distribution. This is so, regardless of the type of water body concerned, because these structures create gradients of current and light. This is clear from the accumulation of drifting fish in the vicinity of these devices (Fig.25) and has been referred to earlier (Section 2.5). Masses of young fish enter the intake devices when they are frightened or fatigued, and when the lights are switched on at night. The maximum effect on fish redistribution occurs in rivers when transit flow velocity is such that  $V = 0.5-0.7V_{\infty}$ , and when the intakes are illuminated at night (Vatshinnikov, 1986). When the light intensity at the mouth of an inlet of the floating pump station 'Syrin-2' in the lower Volga was 40 lux, fish intake was 50-80 000 specimens/m<sup>3</sup>. When the lights were switched off the young fish began to drift with the current again and concentrations began to decrease, eventually approximating natural ones. It is estimated that up to 80% of migrating juveniles in a river may be delayed near bankside water-intake devices.

#### 4.1.4 CAUSES AND MECHANISMS OF FISH ENTRAPMENT BY WATER INTAKES

Fish get into water-intakes only if they happen to be in the vicinity. The process of their entrapment is thus the result of an interaction between the spatial and temporal distributions of fish and the structure of the currents generated by particular water-intakes. A knowledge of the spatial-temporal distribution of fish in a waterbody is therefore invaluable to an understanding of the process of entrapment. Data on the vertical and horizontal distribution of fish, and on the daily and seasonal dynamics of fish distribution at different developmental stages are given in several publications (see e.g. Pavlov & Pakhorukov, 1983).

In trying to understand the mechanisms controlling fish behaviour in the water-intake zone, one must know whether they get into the devices by active or passive migratory processes. The entrapment of young fish by water-intakes is connected with their inability to resist the currents, and with the absence of conditions which permit visual orientation; the same factors which facilitate their drift migrations. Tests carried out with young *Abramis brama* and *Rutilus rutilus caspius* revealed that the light intensities at which mass entrapment begins coincide with the threshold values of illumination for the optomotor

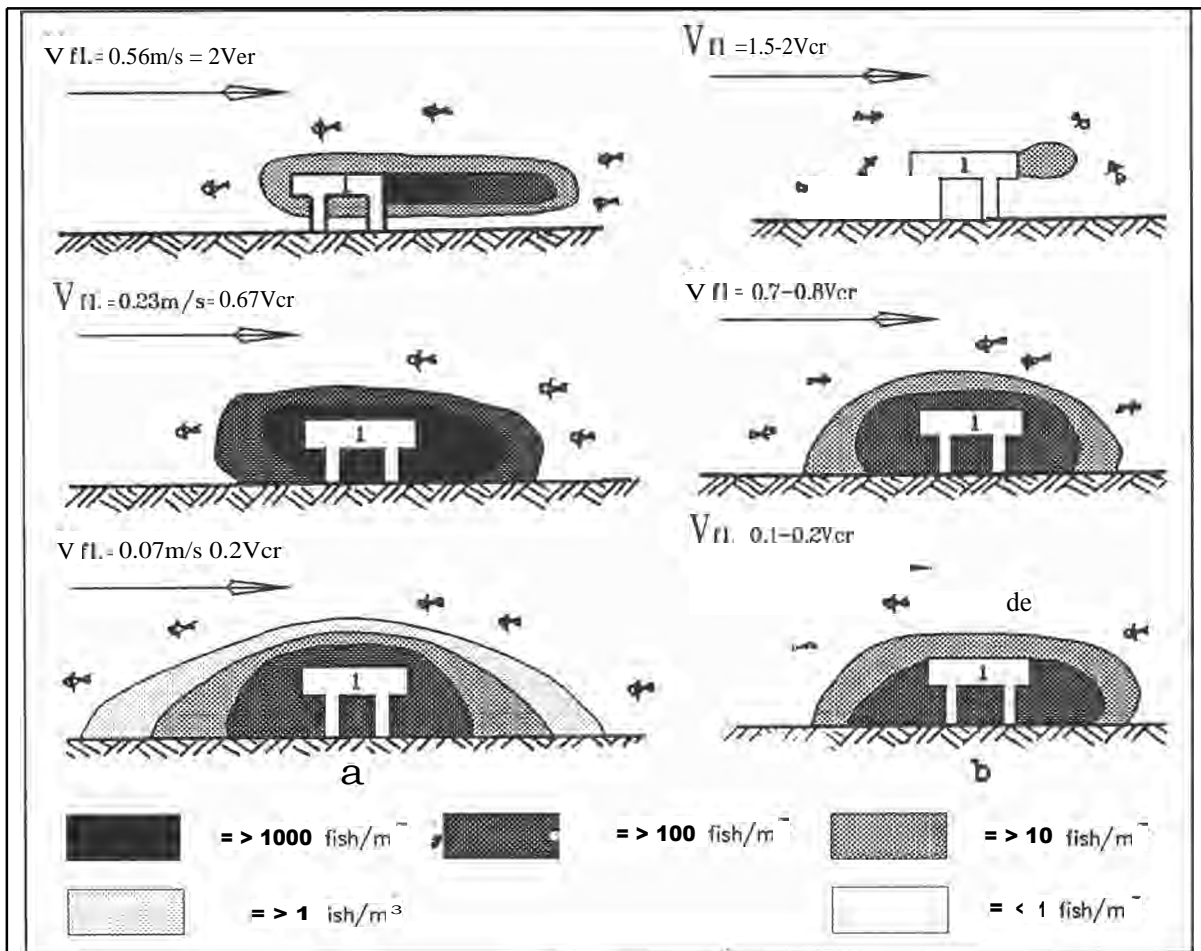

Figure 25.—The distribution of young fish at a natural site adjacent to a fish pass (after Vatshinnikov, 1986): A. daylight distribution, B. night time distribution,  $V_{fl}$  = river flow velocity in m/sec,  $V_{cr}$  = critical current velocity for fish.

reaction. A sharp increase in the entrapment rate for young *R. rutilus* (7-12mm long) occurred at light intensities of 1-0.1 lux. For specimens 15-25mm and 25-30mm long, the corresponding values were 0.01-0.001 and 0.001 lux. The threshold values for optomotor reactions in *R. rutilus* also fell within this range of illumination levels (Pavlov, 1966, 1979). Experiments on young fish which had passed the water-intake devices also showed that when visual orientation was re-established, these fish regained reaction to current and were able to maintain station against significant current velocities.

The main cause of young fish getting into water intakes is their passive drift into the water-intake zone. The other mechanism, whereby fish actively move with the current, is very rare, except in Salmonidae, and the value of the damage due to this mechanism is insignificant in the USSR. The mechanisms and conditions for entrapment are summarized in Table 2.

The pre-larvae and early larvae of some species (e.g. *Clupea harengus*, *Perca fluviatilis*, *Stizostedion lucioperca*) enter water-intake devices principally because they cannot resist the intake currents. However, at later stages of the life-cycle, Teleostei are mostly trapped during the twilight/night hours in water-bodies with high transparency, and throughout the whole day in turbid waters. Thus lack of visual orientation seems to be the chief reason for their entrapment. Later developmental stages of Teleostei enter the water-intakes because of their reduced reaction to current resulting from a lack of visual orientation, and a reduction in swimming activity during the cold months. In spring, mature Teleostei enter the water-intakes as a consequence of both spawning and post-spawning activities, but in particular, because of their

TABLE 2. TYPES AND MECHANISMS OF FISH ENTRAPMENT BY WATER INTAKES

Type of entrapment	Reason for entrapment	Stage of life-cycle	Prevailing conditions	Time of day
Passive entrapment, cannot resist current	1. Absence of conditions for orientation	1. Larvae and early fry, Teleostei 2. Larvae and young <i>Acipenseridae</i>	Reduced light, no optomotor reaction  Ascent into water column	Twilight/night  Not known
	2. Reduced current reaction and loss of conditions for visual orientation	All stages	1. Decrease of Secchi disc transparency below 20cm 2. Lack of light, but Secchi disc transparency above 30cm	24 hours  Twilight/night
	3. Physical inability to resist current	1. Pre-larvae and young fish at first stage of larval development	Specimens encounter intake — current velocity exceeds $V_{cr}$  Casual capture by intake current — velocity exceeds $V_{cr}$	24 hours  24 hours
		2. All stages		
4. Reduced swimming activity caused by abiotic and biotic factors	All stages	Changes of water temperature, oxygen concentration and/or physiology of fish	24 hours	
Active entrapment, swimming with current	1. Fright/escape reaction	All stages	Reaction to predator or hydro-acoustic or other environmental disturbance	Casual — any time
	2. The 'following' reaction	Young fish from moment of schooling	Process not known, mainly in Salmonidae during the polar day	Daylight

post-spawning downstream drift migration when their reaction to current and swimming performance are poor.

#### 4.2 FISH PROTECTION MEASURES

These are based on three basic principles of protection formulated by Pavlov & Pakhorukov (1973):

- An ecological principle, that knowledge of the regular patterns of fish life, and the rates at which different species get into water-intake devices, can be used to protect them.
- A behavioural principle, that knowledge of the behaviour of fishes to external stimuli such as electric fields, light levels, sounds and screen nets, can be used to protect them.
- A physical principle, that physical phenomena and devices can be employed to protect fish. Physical devices include mechanical barriers, and physical phenomena include differences between the relative densities of fishes and water, and other hydrodynamic effects.

The choice of methods is based either on these individual principles or on combinations of them. The particular method of protection employed determines the type of influence exerted on the fish under protection. The specific devices and measures which are employed are usually related to the overall design and organisation of the project. However, a lack of appreciation of the relationships between the principles is responsible for the current confusion of both methodology and terminology in this field. The development of new structures, and the search for optimum operational regimes should be based upon the application of these principles.

#### 4.3 FISH PROTECTION BASED ON ECOLOGICAL OBSERVATIONS

Ecological methods of fish protection are potentially very useful, but are not yet widely applied. Such measures could lead to substantial reductions in the numbers of fish trapped. The regulation of water removal is an ecological measure with considerable potential for preventing fish from entering water intakes. The distribution of young fish throughout an area of water is not uniform, because spawning sites are localised, as are feeding and overwintering ones, and migratory paths are narrow and only contain fish temporarily. Based on this knowledge several protective measures are suggested below.

Since the highest concentrations of eggs and fry occur only in the spawning grounds, placing water intakes beyond them will avoid mass intake of the youngest stages. Water intakes should not be placed where fish accumulate in reservoirs and rivers, such as along migratory paths. For example, it would be imprudent to undertake large scale water removal at **Kamennyi** Yar village on the lower Volga where concentrations of sturgeon may reach **2200/m**. Further, water intakes should not be placed at river mouths and deltas, or where tributary streams enter lakes or reservoirs, because fish tend to drift into these areas from spawning and feeding grounds, and to concentrate in them.

The correct siting of water intakes relative to a river bank is perhaps the most important measure of fish protection. Water removal from the littoral should be avoided as far as possible since it is usually damaging to fish populations regardless of whether abstraction is from a river, reservoir or lake. These zones tend to be warm and rich in food, and fish concentrate in them and intakes should be placed in deeper offshore waters wherever possible. Such a step was taken in the Volgogradskaya Reservoir, when an intake head was moved from the shoreline to a depth of 6m, with a two hundredfold decline in the capture of young fish (Nikonorov & Mel'nikova, 1974).

Water can also be abstracted from different zones at different times of the year, *e.g.* in reservoirs where the highest concentrations of fish are found in littoral sites at the beginning of summer, but in **pelagic** sites in late summer (Kuznetzova, 1980).

In rivers fish are known to concentrate along the concave sides of river bends, (*Fig. 33*), in some cases 50–70% of the drifting fish becoming aggregated into 25% of the river cross-section. The main cause of this redistribution is the transverse circulation which develops at bends. Many more fish enter water intakes along the concave bank as compared with those along the convex bank, other parameters being equal. Maximum entrapment is achieved at the outlet from the river bend on the concave bank, while the

corresponding site on the opposite bank yields the minimum entrapment. However, some deviations from this picture occur if the flow moves through two consequent sharply and oppositely-oriented bends, as revealed by studies on the Ural River (Pakhorukov *et al.*, 1985). In this case, at the second bend, where the greatest depths were close to the concave bank, the maximum concentrations were found to be closer to the middle of the river, but at the convex bank there was a small area with a lowered fish concentration. The water intake for Guryev town was therefore placed in the latter position. The efficiency of ecological protection achieved here is estimated as 81.5%. Had the intake been sited 180-200m farther upstream, where the main line of fish migration was close to the bank, damage would have been very high. This study confirmed the need for bio-hydraulic research in choosing sites for water-intake devices.

**Vertical stratification of fish distribution** in a water flow can also be used for fish protection. This can be achieved in several ways. Water intakes can be placed in the layer of minimum fish concentration. In the Kuban' River the highest concentrations of *Acipenser stellatus* larvae are found at the bottom. Thus, at least in summer, it would be advisable to place water intakes not lower than 2m above the bottom.

Floating booms and deflectors can be placed in front of intakes to limit abstraction from the surface layers. These devices are effective only where the highest concentrations of fish are in the surface layers and clearly they would be harmful if the highest concentration of fish was in the near bottom layers. A floating boom was used to protect fish for the first time in the Ali-Bayramlinskaya hydro-electric plant on the Kuban' River (Baranyuk & Tikhomirov, 1969); the depth of the deflector screens is about **1m**, and the level of fish protection achieved is estimated at 67%.

Hydraulic screens and 'umbrella-shaped' fish-protecting devices also serve to separate the water layers full of fish from the influence of the water intakes. The so-called 'umbrella-shaped' devices (*Fig. 26c*) are said to be most effective (Filchagov & Bolshov, 1980). Industrial tests over many years have indicated their efficiency, at rates of water discharge up to 25m<sup>3</sup>/sec, as 55-100% depending on operating conditions and the size and species composition of the community under protection.

Intake heads equipped for variable depth water removal make it possible to minimize the impact of water abstraction on fish stocks since the vertical distribution of fish varies diurnally and seasonally, depending upon species and stage of development. The influence of such variations on entrapment has been confirmed by data obtained over a whole year from the Mostiste Reservoir (Barus *et al.*, 1984). Examples of devices for regulating the depth of water removal are given in *Fig.26e,f*.

'Scoops' which separate bottom from surface waters may also be used to protect fish. A 'scoop' fences off part of the water from the main body and includes a device which prevents the accumulation of alluvium. The principle involved is that streams (filaments) of high current velocity at the surface, deflect the 'scoop', while bottom water of lower velocity does not. If the main concentration of fish is in the water of low velocity, then such devices can be used to separate the water supply to the intakes, ensuring that the fish-rich bottom water is excluded.

**The diurnal regulation of water abstraction** is used where there are distinct diurnal patterns of entrapment at water-intakes. It is one of the most important methods of fish protection and may be used where the Secchi disc transparency exceeds 20cm. Daily regulation of abstraction may be achieved in one of two ways:

A. By limiting water removal to the hours of darkness. In some years this limitation is imposed on intakes without fish protecting devices, such as those used to supply water for irrigation in the Astrakhan region (Pavlov, 1979). This limitation is also imposed in the southern Ukraine, *e.g.* on abstraction from the Khakovskoye Reservoir for the Severo-Rogachevskaya irrigation system during periods when entrapment is high (Mussaenko *et al.*, 1982).

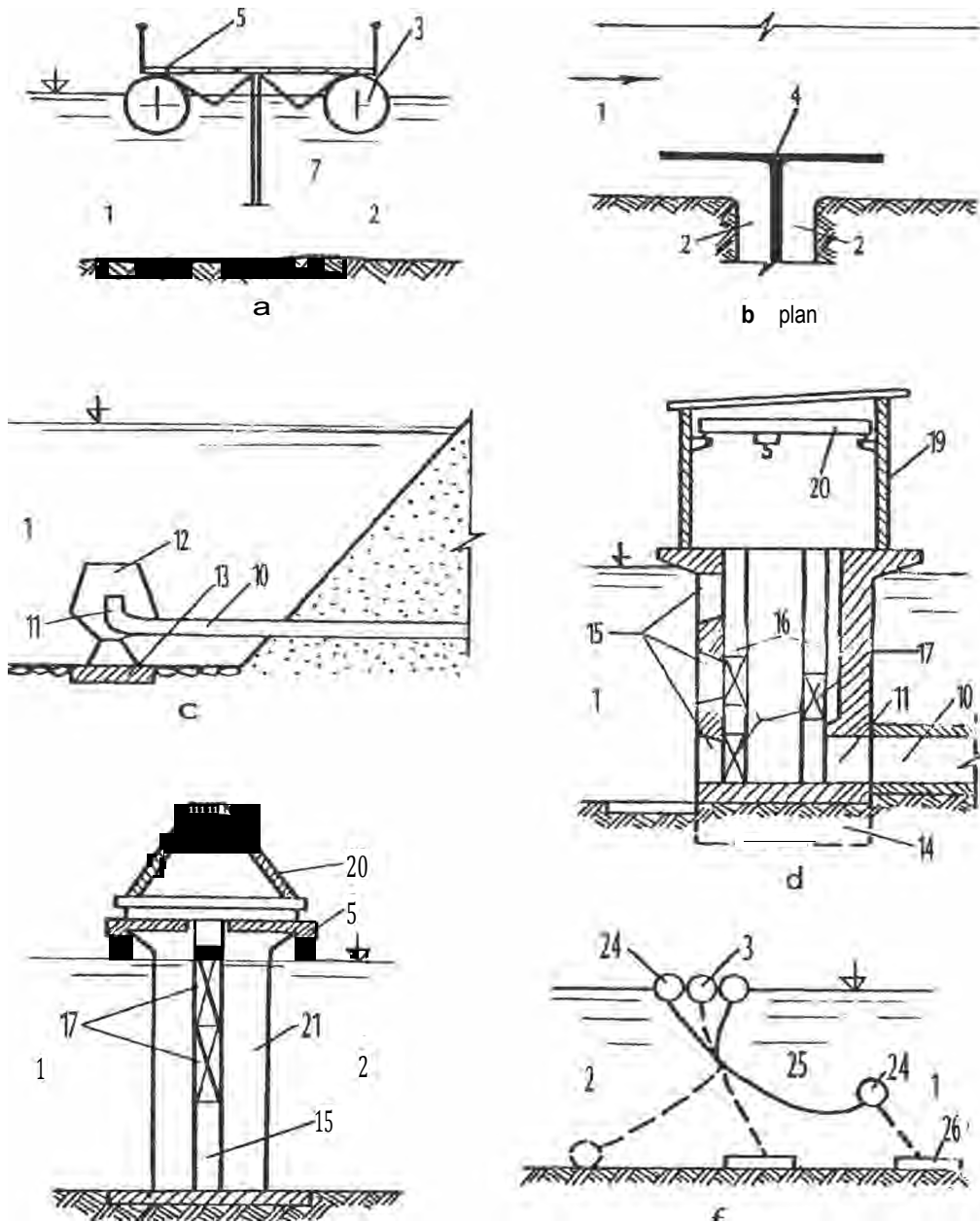

Figure 26.— Devices for the vertical control of water removal: a. flow deflectors, b. scoops with top & bottom supply, c. 'umbrella' shaped heads, d. intakes with vertically adjustable heads, e. vertically adjustable zone barrier, f. moveable flexible zone barrier.

1. water-supply canal, 2. spillway entrance, 3. floats, 4. debris guard wall, 5. platform, 10. water-intake pipe, 11. water-intake, 12. umbrella head, 13. supports, 14. internal sump, 15. water entry ports, 16. grooves for gates, 17. entry port gates, 19. housings, 20. gantry, 21. pile sheath, 24. adjustable float, 25. flexible panel, 26. concrete anchor blocks.

B. By constructing water-accumulating basins. Where nocturnal supply is necessary water-accumulating basins provide a solution. The basins fill during the day, when fish capture is low, and supply water during the night.

There is also a significant seasonal variation in the concentration of young fish in a water body. The greatest variations are for some diadromous and semi-diadromous species. If rivers are not impounded, the majority of these fish drift to the sea during the summer months and the seasonal variations in fish concentration which occur are magnified in river mouth areas. Where dams are present and the water flow is regulated the following seasonal protection measures can be adopted.

A. Water removal can be limited during the periods of highest fish concentration. This policy is already implemented in the southern Ukraine. In spring no water removal occurs during a 5–8 day period.

B. Water storage basins can be used. Both natural and artificial reservoirs are appropriate for this purpose. For example, two intermediate reservoirs (Chernoyarskoye and Kalmytskoye) have been built on the Volga–Chogray irrigation canal (still under construction) which should transport **2km** of water per year in Kalmyk ASSR. They will be filled in the cold period each year when the mass migration of young Acipenseridae does not occur.

It is clear that ecological methods of fish protection have considerable potential. However, to realise this requires further study of drift migration, and of the patterns of entry of fish to water-intakes. The application of ecological **methods** will be effective only if they are correlated with studies on the spatial and temporal distribution of young fish in the specific water body needing protection. This is particularly true when zonal and vertical regulation of water removal is being considered.

#### 4.4 PHYSICAL METHODS AND DEVICES FOR FISH PROTECTION

The first methodological approaches to the problem of fish protection perceived the fish as physical bodies. Engineers supposed that the single aim of fish protection was to exclude fish from water-intakes. This approach is exemplified by the development of net barriers and screens to be placed in front of the intakes. The concepts and processes employed are similar to those used to remove inert bodies from a fluid. Two later, more sophisticated, methods are circulatory separation and air lifting.

##### 4.4.1 SCREENING METHODS

During screening processes, the survival of fish pressed against the screen depends mainly upon the velocity of the flow, the size of the fish, the size of the mesh, the strength of the fish's integuments and tissues, and the length of time they are trapped against the screen. Mortality in large fish is generally due to asphyxia, but in small fish to physical trauma as well. Data for screens with meshes of **1mm x 1mm** and 1.7mm x 1.7mm, located at **90°** to the axis of flow, are presented in Fig.27.

When the screen is located at an acute angle relative to the water flow, fish drift along it. This drift is connected with peculiarities of the hydraulic flow in front of the screen, as well as with the swimming movements of the fish. This lateral drift encourages the fish to struggle to free themselves from the screen, but in consequence they suffer more damage in the form of scale loss and gill cover damage. In the end, this leads to higher mortality rates than is observed where screens are not aligned to permit lateral drift of fish.

The ratio of the size of fish to mesh size is also important. Thus *Rutilus rutilus caspius* and *Abramis brama*, less than 23mm long, were not restrained by a mesh size of 4mm x 4mm, aligned perpendicular to a



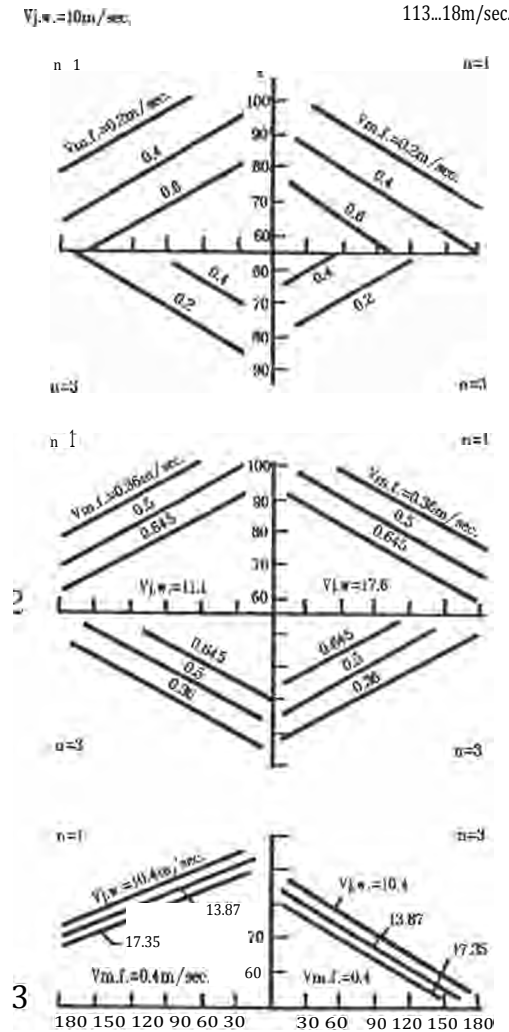

Figure 27.— Fish survival in relation to duration of contact with net barrier, after Muravenko 1979 :  
 X axis duration of contact with barrier in minutes, Y axis survival of fish expressed as a %,  $V_{wf}$  velocity of water flow,  
 $V_{jw}$  velocity at outlet of washing-flow, n number of fish contacts 1. *Abramis brama*, 15-20mm long,  
 2. *Srizostedion lucioperca*, 20-25mm long, 3. *Acipenser stellatus*, 24 hours old.

current which had a velocity of 0.5-0.9m/sec. Specimens 23-26mm long partly passed through the net, but as a rule, were caught by their gills. Specimens 28-30mm long rarely passed through Pavlov, 1970 . Some further data are given in Fig.28.

The use of perpendicular screens relies entirely upon technology to free fish from the screen, and to this end hydraulic jets are continuously operated to wash the fish away. However, according to Muravenko 1979 , the use of jets is strongly related to fish mortality. It therefore appears that the use of such screens is of dubious value. They are best suited only to protecting large fish, i.e. those exceeding 50cm in length, and are certainly unsuitable for the young stages of Cyprinidae and Percidae.

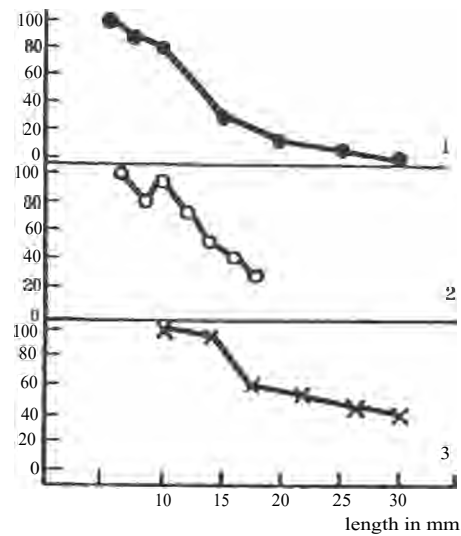

Figure 28.— Fish capture by water intakes equipped with protection screens, after Pavlov & Pakhorukov (1973): 1. with 3 x 3mm mesh screen, various species; 2. with 2.8 x 2.8mm mesh screen, *Stizostedion lucioperca* and *S. volgensis*; 3. with 2.8 x 2.0mm mesh screen, *Clupeonella delicatula*, X axis = length of fish in mm, Y axis = % fish capture.

#### 4.4.2 CIRCULATORY SEPARATION METHODS

These methods are based upon such physical parameters as the differences in density which exist between fishes and water. When the densities of the fish exceed that of water they accumulate in the centre of a circulatory flow; when the density is lower than that of water they accumulate at the sides. In the **vortex fish protection chamber**, water enters a lower chamber tangentially, and consequently develops a rotational flow (Fig.29). Young fish are trapped in the vortex and are then diverted from it. The results of field investigations under conditions of high turbidity in the Kura River have shown that the efficiency of these devices for ordinary fishes is 90-98%, but for Acipenseridae it is only 75-80% (Gasnov, 1981). The current velocity in these devices are 0.6m/sec., and they are suitable for protecting fishes from small water-intake devices, where the throughput does not exceed 1.5m/sec.

#### 4.4.3 AIR-LIFT METHODS

Air bubbles are able to carry discrete particles upwards with them when they are rising through water, even if the specific gravity of the particles is greater than 1. Several mechanisms are thought to operate in this process. Lifting is at least partly due to floatation, where many micro-bubbles adhere to the surface of the ascending body, reducing its overall specific gravity. In addition, some influence is exerted by large rising bubbles acting upon the undersurface of the ascending body. This mechanism functions best when the ascending body has a density close to that of water. It is also believed that vertical water movements are generated in the rising bubble plume which tend to carry the rising body with them. However, in using this technique to lift fishes, the fact that there will be a horizontal flow generated by the water-intakes must be considered. The process will only work if the vertical flow velocity exceeds the horizontal one. Despite numerous suggestions that the technique should be employed to lift fish, little research has been devoted to evaluating the precise mechanisms of the lifting process. Most workers consider that the generation of vertical water flows is the principal mechanism involved, but it seems likely that more attention should be given to the influence of large rising bubbles.

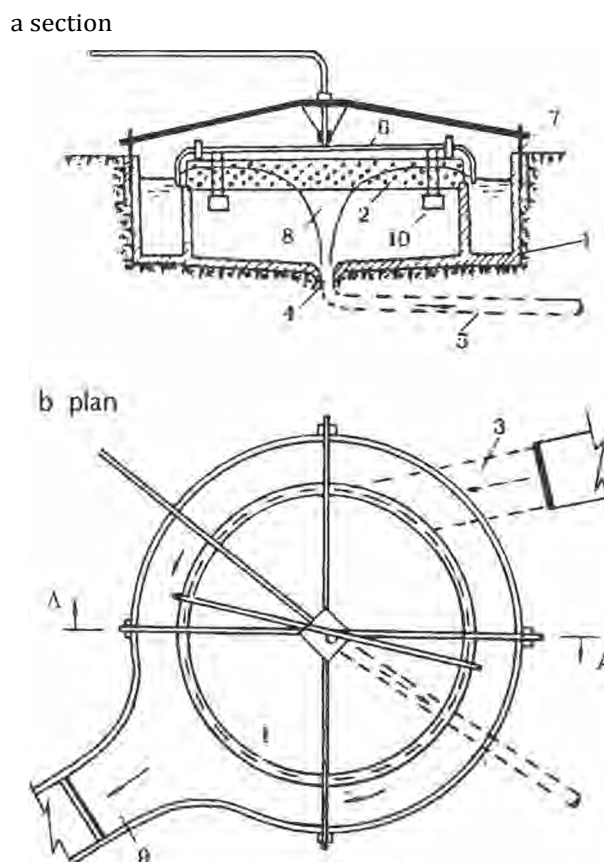

Figure 29.— PBK-2 Vortex Chamber a section, b plan : 1. concrete basin, 2. screen, 3. intake pipe, 4. discharge outlet, 5. diverter pipe, 6. screen washer, 7. support structure, 8. vortex cone, 9. main discharge, 10. washing-device drive.

The maximum vertical velocities,  $V_{\max}$  (Fig. 30) for an air-water emulsion may be calculated Mussaenko et al., 1982 from the formula:

$$V_{\max} = \frac{qg}{\gamma_w} - \frac{H}{\gamma_w} \ln \left( \frac{P_a/\gamma_w}{P_a/\gamma_w - 0.22H} \right)$$

where:

$q$  the specific rate of air discharge in  $\text{m}^3/\text{sec}/\text{m}$  of pipeline.

$H$  the depth of immersion of the pipeline in metres.

$\gamma_w$  = the specific gravity of the water in  $\text{t}/\text{m}^3$

$P_a$  the atmospheric pressure in  $\text{t}/\text{m}^2$  and

$g$  9.8  $\text{m}/\text{sec}^2$

The results of investigations carried out by different institutes show that the optimum value for 'q' lies between 0.003-0.006  $\text{m}^3/\text{sec}/\text{m}$  Mussaenko et al., 1982 .

It is well known that air-lift method has been used as the basis for a number of structures where the young fish are either carried away into a special diverting device, or into a part of the flow not destined to enter the water intakes. A simple system is used on the Kakhovskaya irrigation system which has an output of 530  $\text{m}^3/\text{sec}$ . Here the young fish enter the stream of air bubbles and are lifted into the surface layers, little

of which enters the intakes. Protection efficiency is estimated as 12-36% (Filchagov, 1980; Mussaenko *et al.*, 1982). The numbers of fish entering the water-intakes is still high, but the level of protection is greatly increased if special jet-guiding elements are placed in the upper part of the screen, to redistribute the rising bubble plume. This is the case at the ZIL power plant on the Moskva River (intake velocity is **10m /sec.**) where investigations indicated that the level of protection afforded young *Perca fluviatilis* and *Stizostedion lucioperca* with lengths of 14-32mm, was  $81.8\% \pm 3.6\%$  (Pakhorukov, 1984; Kolesnikova, 1985).

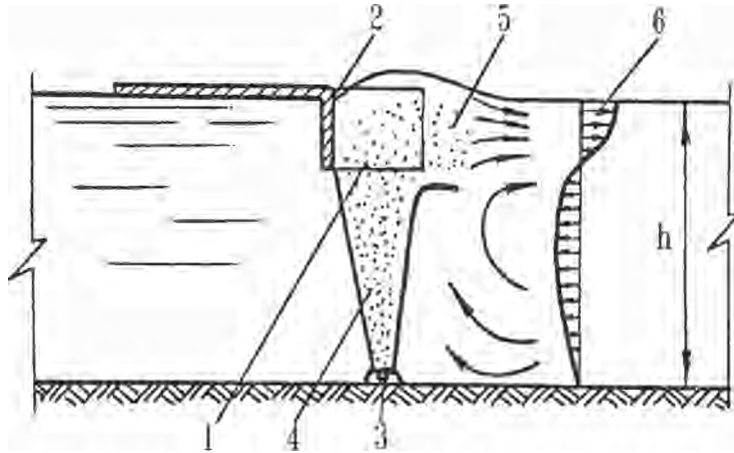

Figure 30.—Air-bubble device: 1. jet-guides, 2. reflector screen, 3. perforated tube, 4. air/water screen, 5. surface flow, 6. curve of current velocities.

#### 4.5 METHODS OF PROTECTION WHICH EXPLOIT FISH BEHAVIOUR

These are based upon the responses of fish to the stimulation of their visual, acoustic, tactile and pressure-receptors. In general the stimuli used are ones which provoke escape reactions which lead to the fish moving away from the water-intake zone where the stimuli are received. However, it is possible that stimuli which attract the fish could be used to divert them out of the flow about to enter the water-intakes. Other stimuli might be used to help passive migrants recover the ability to orientate themselves. Further, the same stimuli could be both repellent and attractive, depending upon their strength and the species concerned, and could thus be employed in different protective devices.

To date methods based on several different stimuli, light, hydraulic, electrical, tactile-hydraulic, sound and pressure, have been considered for fish protection. However, methods involving sound and pressure, which depend upon the hydrostatic reaction of fishes, have not yet led to the development of experimental structures and are not considered here. Particular attention is paid to the use of tactile-hydraulic stimuli in association with impermeable barriers, as this method is the most highly developed and is used in more operating structures than any other.

##### 4.5.1 METHODS USING LIGHT

Some fish species are attracted to artificial light sources while others are indifferent to them, and yet others move away from them. The reaction to light is connected with a number of abiotic and biotic factors, and therefore varies, even within a single species. In young specimens of most Teleostei, light is necessary for orientation in a water flow. Thus methods involving light stimuli could be attractive, orientational or repellent.

Because the capture of fish by water-intakes during drift migration is largely due to a loss of visual orientation, it has been proposed that light be used to stimulate recovery of orientation and rheoreaction (Pavlov, 1966, 1970, 1979). Observations have shown that for this it is necessary to locate the visual cues in the water-intake zone. Such cues may be reeds or branches of trees. With satisfactory cues, and with a water-intake of  $1\text{m}^3/\text{sec}$ , the protection of Cyprinidae and Percidae over 14mm long, was 84-91% effective. A similar low fish mortality at the intake for the hydroelectric plant at Bergum, which also uses a light protection technique, was noted by Haddingh (1982). Notwithstanding these successes, since artificial lights often attract vast numbers of young fish, their deployment has to be carefully considered. If lights are placed in a water-intake zone where current velocities are greater than the critical velocities for the fish in the flow, mass mortality may occur.

The influence of light on the capture of Acipenseridae has to be considered separately. In these fish, the tactile sense is of primary importance for orientation. Although in specimens 50-70mm long, there is a distinct daily rhythm in their capture rates by water-intakes, the application of artificial light did not significantly influence the quantity of fish captured.

Methods using a light stimulus can be effective only if the Secchi disc transparency exceeds 20cm, and it is important in using such methods to have a knowledge of the behavioural responses of young fish to variations in light level. The distance from the water-intakes where illumination is applied depends upon the time it takes for the fish to respond to the new light conditions. A fish retina adapts to the change from dark to light within a few seconds, nevertheless, experiments show that recovery of the reaction to current takes several tens of seconds (Pavlov *et al.*, 1986). The length of the illuminated path on the approach to the water-intakes depends upon the velocity of the flow and on the relationship of the fishes' cruising speeds to that of the flow. Illumination level must exceed the threshold level for the visual mechanism of the reaction to current, and, in this context, a light level of between 1-10 lux is generally sufficient. Migrants then drift into the illuminated zone, regain the reaction to current, face the current and swim away.

#### 4.5.2 METHODS USING ELECTRICAL STIMULI

For a long time there were high hopes for these methods, and the first electrical fish-protective devices were created in the USA in the 1920s. They were based on the fact that fish tend to avoid fields of high electrical tension. Most of the devices used are of the 'two-row' type developed by McMillan & Berky where the rows of electrodes were of opposite polarity, but Strakhov (1965) has developed a single row electrical barrier, ERZU-1, in the USSR. This is distinguished from the two row type by a smooth decrease in tension with increase in distance from the electrodes.

The reaction of fish to an electrical field depends upon their size, and the highest tensions are required to influence the smallest fish. For the ERZU-1 device, fishes can be protected down to a length of 35-40mm, but the protection of smaller fish requires tensions which are lethal to large fish. However, in practice, ERZU-1 barriers built at water-intakes, were found to be of little use, even for fish over 40mm, and this is in agreement with the findings of Clay (1961) and Vibert (1967) who concluded that electrical barriers were of no value in fish protection. It seems that at certain electrical tensions the rheoreaction is depressed and fish are captured by the approach flow and carried to the intakes. However, with a decrease in flow velocity and the creation of transit currents, there are better conditions for fish orientation. Thus there is still some hope that techniques which moderate the flow velocity will be able to be used in conjunction with improved electrical barriers for the protection of fish over 5cm long.

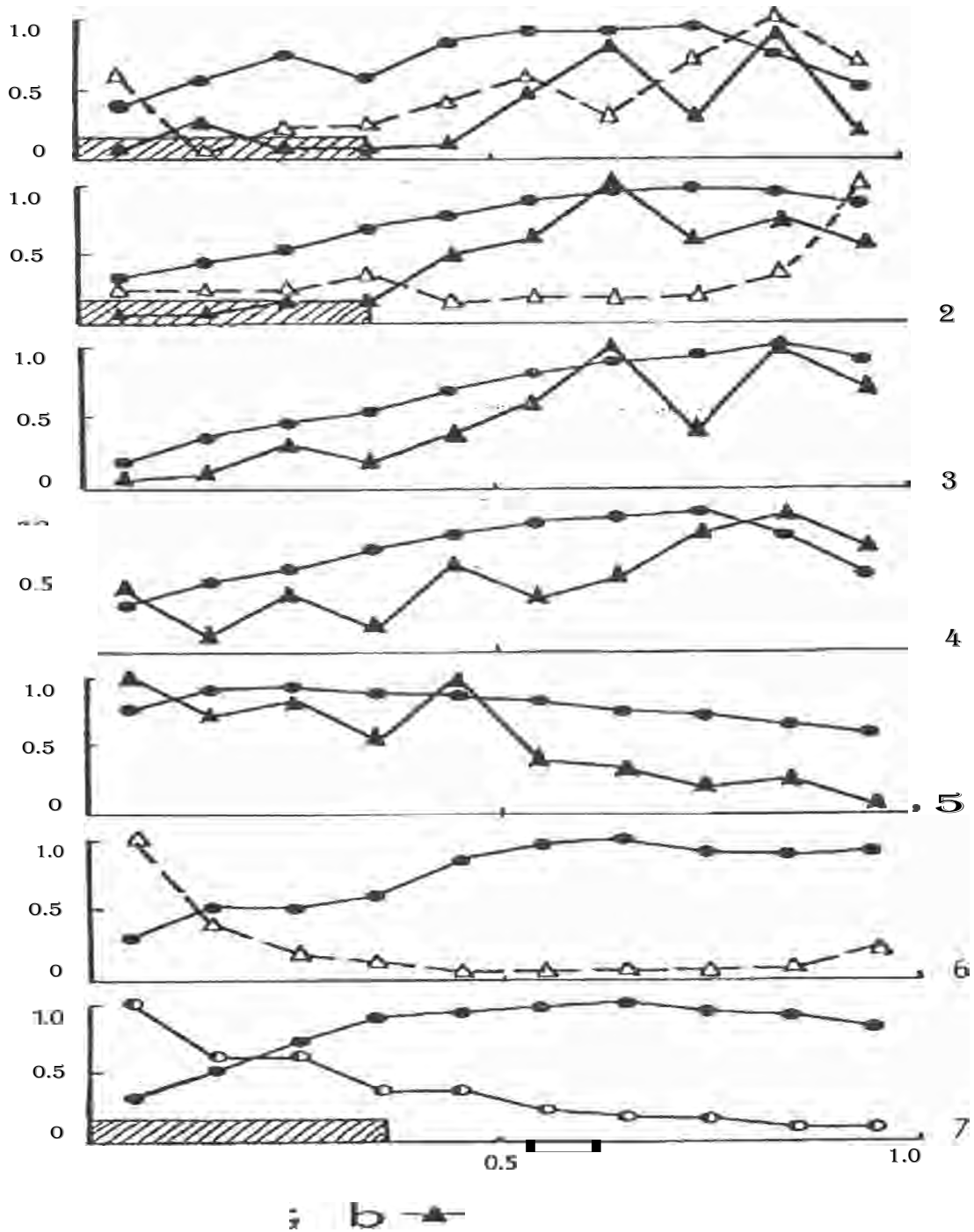

Figure 31.— The horizontal drift distribution of young fish under velocity gradient conditions: *Diags. 1-5, during the hours of darkness; Diag 6, during daylight hours and, Diag 7, the comparable drift of dead fish*. *a.* = velocity curve across width of chute, *b.* = distribution of fish in natural drift,  $\square$  = distribution of fish released at 1st section,  $\square$  = distribution of dead fish. X axis = chute length in  $\square$ , Y axis = relative concentration of fish (N) and relative flow velocity (V) cross hatching = part of chute where fish are released.

#### 4.5.3 METHODS EMPLOYING HYDRAULIC STIMULI

These methods are based on the discovery that young drifting fish redistribute in a flow under the influence of velocity gradients in the current and transverse circulations. Several technical designs utilising this method are still under evaluation, despite which, they are considered here because of their promise.

If a velocity gradient occurs across the width of a current, *i.e.* if a transverse gradient exists, in darkness, the young fish are moved towards the zone of highest velocity (*Fig.31*) according to Pavlov & Shtaf (1981). Redistribution of dead fish and non-living objects does not however, occur and this therefore suggests that an active mechanism is involved in the redistribution of fish. In experiments with a chute 10m long and 1m wide, Pavlov & Shtaf succeeded in accumulating 47-52% of transiting fish in 25% of the chute section and 70-87% in 50% of its section. The most effective redistribution was obtained using asymmetrically positioned current accelerators, which produce the strongest transverse gradients (Pavlov & Pakhorukov, 1983).

In addition to the use of transverse current velocity gradients for the re-distribution of fish, the blades used to control siltation (*Fig.32*) generate a transverse circulation, and experiments have shown that this redistributes young drifting *Rutilus rutilus* across the surface layers (Pavlov *et al.*, 1982). Experiments were undertaken to assess the influence of transverse flow circulations and transverse current velocity gradients

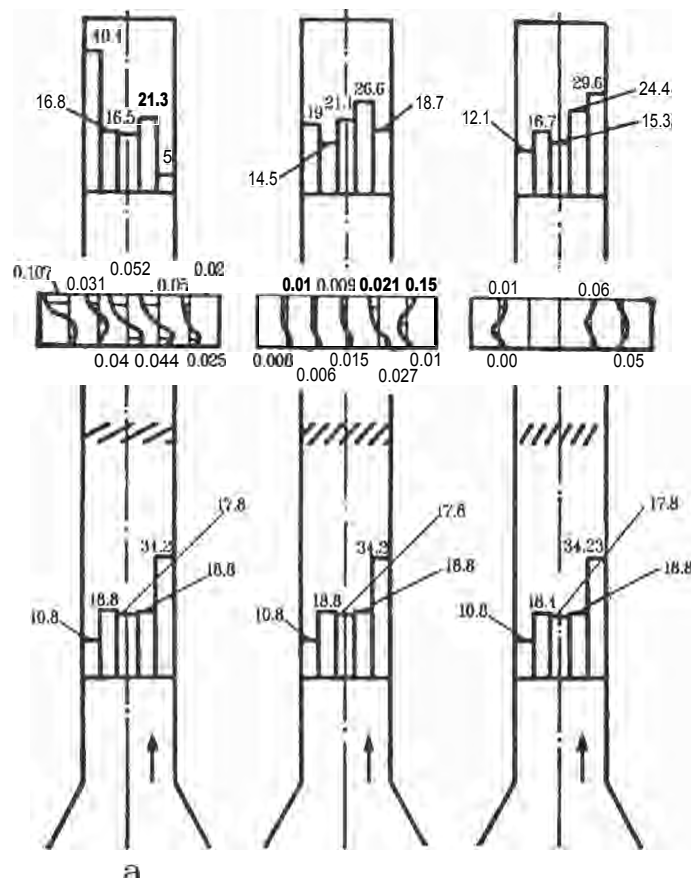

Figure 32.—The influence of the jet diverting blades of Potapov, on water flow and the distribution of drifting fish with a constant approach flow of 55cm/sec: a. with blades set at 60°, b. with blades set at 45°, c. with blades set at 30°, bottom histograms = fish distributions at inlet, top histograms = fish distributions after influence of blades, middle diagrams = velocity gradients.

at artificial bends in chutes and small rivers with curvature radii between 7 and 112m (Fig.33) (Pavlov *et al.*, 1982; Malevanchik & Nikonorov, 1984). Large quantities of young fish were found to be redistributed to the concave bank from where they could be led off into fish-diverting devices, and engineering designs are now being made on the basis of this work.

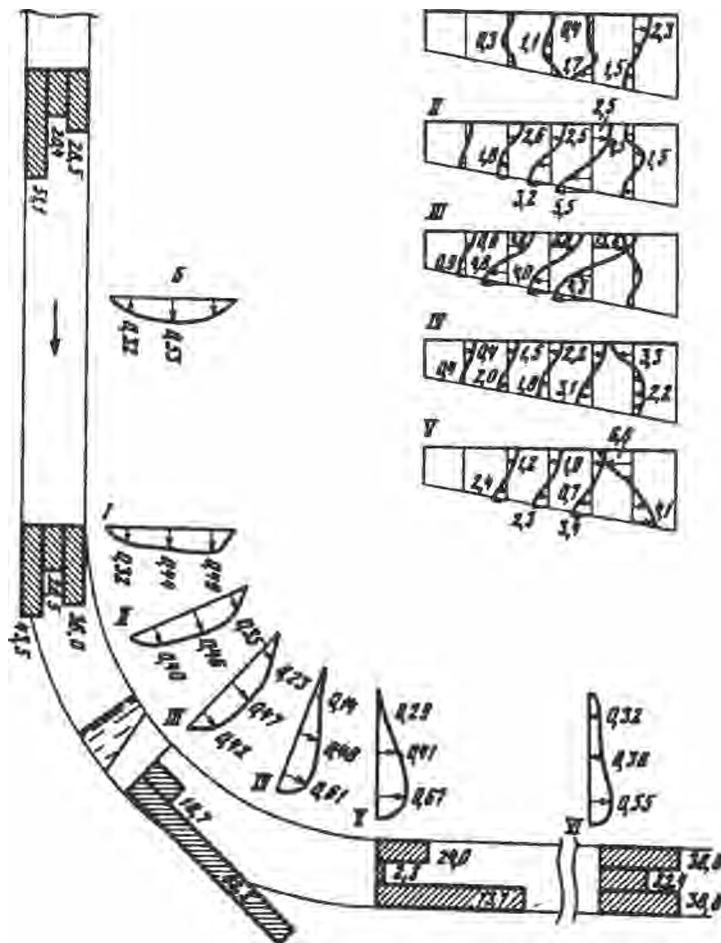

Figure 33.— Data on fish distribution and current velocities obtained from field studies using a chute with a 15m radius of curvature, mean initial flow velocities of 42cm/sec, and with the bottom sloping down towards the convex wall. I-VI = sections: A. % fish distributions across the flow, B. current velocities in m/sec, across channel, C. cross-sections through channel showing the boundaries of discrete current elements.

In recent years much attention has been given to the design and development of vertical fish-concentrators (Barekyan & Lupandin, 1987; Nikonorov & Malevanchik, 1987). In these devices the flow is separated into an upper layer, in which the fish accumulate, and a lower layer which goes to the water-intakes. The young fish are first lifted by a baffle at the entrance to the concentrator, to the upper layers where they are retained by a combination of vertical and horizontal current velocity gradients (Fig.34). Here the ratio of the vertical to the horizontal component of current velocity is 1:4. The walls of the concentrator chute narrow, and the young fish pass through an area with a succession of baffles, and are concentrated towards the end of the chute, and remain in the upper layer. From here they move to a diverter at the end of the concentrator. This device makes use of a fish's responses to both pressure and current.



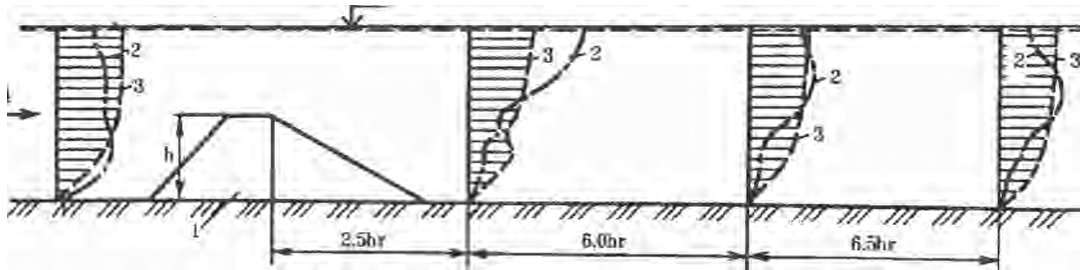

Figure 34.— The influence of an obstacle (barrier) in a water flow on the distribution of fish: 1. obstacle, 2. curves of fish distribution before and after the obstacle, 3. curves of current velocity distribution, 4. direction of flow,  $h$  = height of obstacle in metres.

When the young fish, which are adapted to the pressure of the lower layers, are lifted to the upper layers, their swim bladders are immediately dilated. This makes it difficult for them to submerge once they have passed the baffles. It is important to know the latent time for the compensatory process which will allow them to dive to their previous depth, and the strength of the downward vertical flow component directed to the water-intakes. This latter component must not exceed the critical velocities for the fish. The average value of this component is below, or equal to,  $0.065\text{m/sec}$  (Malevanchik & Nikonorov, 1984).

The mechanical arrangements of these devices is shown in *Fig.35*. Vertical fish-concentrators were subjected to both hydraulic and biological tests over many years and thereafter on the water-intakes of the Kalininskaya Thermolectric Power Plant-3. In the test sites, a chute discharge of  $2\text{m}^3/\text{sec}$  was used, while on the intakes it was  $12\text{m}^3/\text{sec}$ . Protection of 48-57% was achieved for fish 6-12mm long, and of 71-80% for

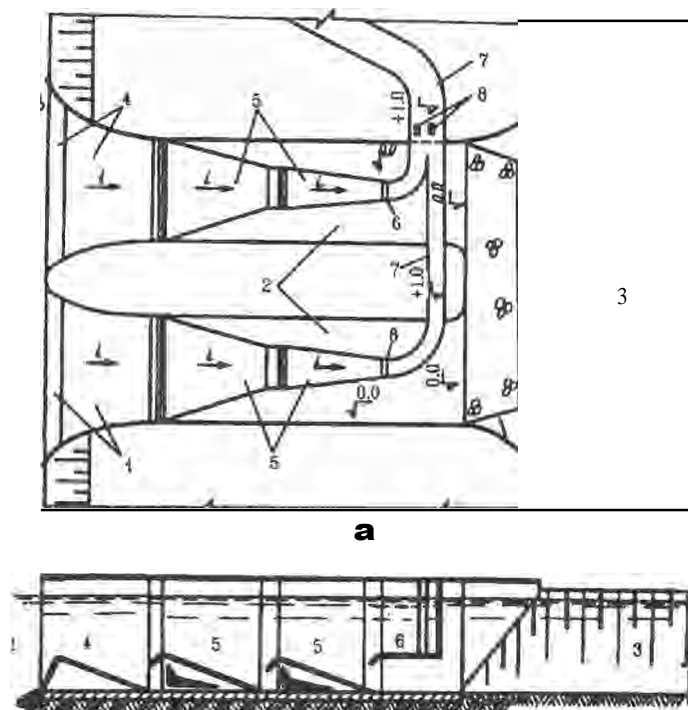
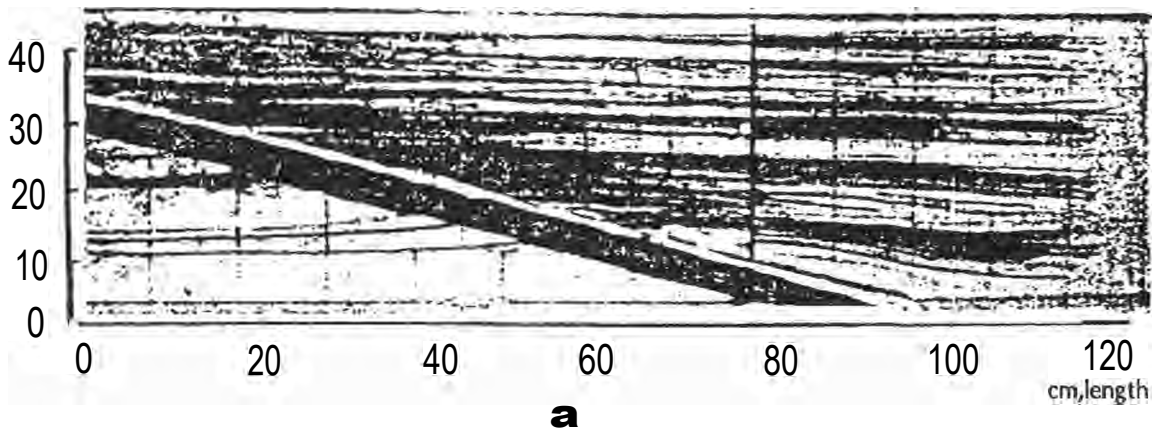

Figure 35.— Diversion device based upon differences in the vertical distributions of fish; a. in plan, b. in cross section (after Malevanchik & Nikonorov, 1984): 1. water intake basin, 2. water supply canal, 3. water intake canal, 4. entrance section, 5. concentrating

fish 12-40mm long (Barekyan & Lupandin, 1987). Concentrators of this type are currently under construction for a number of power station and irrigation intakes.

#### 4.5.4 THE USE OF TACTILE-HYDRAULIC STIMULI WITH PERMEABLE BARRIERS

This combination of stimuli provides the basis for the design of several different structures. These are principally the effects of sharp changes in the structure of the water flow (*Fig.36*) and tactile and visual



$$V_{av} = 20\text{cm/sec}; U' = 0.2\text{cm/sec}; U'_{r_{-1}} = 1.15\%; V = 1.8\text{Hz}$$

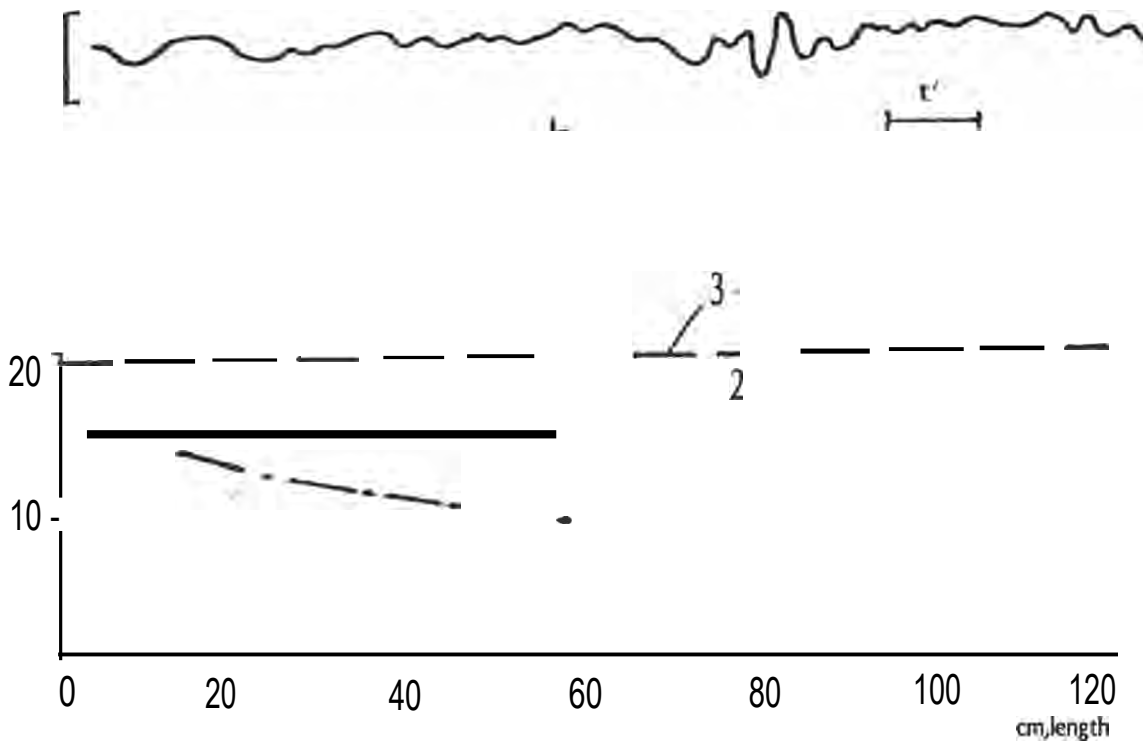

Figure 36.— a. Flow structure in front of a panel barrier with a mesh size of 2mm. b. Pulses in current velocity 5cm in front of barrier:  $V_{av} = 20\text{cm/sec}$ ;  $t = 1\text{ sec}$ ;  $U'$ (turbulence intensity) =  $0.2\text{cm/sec}$ ;  $U'_{r_{-1}}$ (relative turbulence intensity) =  $1.15\%$ ;  $\gamma$ (frequency

changes. The application of these stimuli varies quantitatively between processes, but from a design point of view the structures used are essentially barriers which influence flow structure. These barriers are characterised by their varying permeability to fish, and by their permeability to the current. Three levels of permeability to fish can be identified; impermeable; physically permeable, where the fish can be carried through clear spaces in the barrier by the current; and behaviourally permeable, where the fish have the ability to pass **through** the barrier by virtue of their own activity.

The chief quantitative index of permeability to fish ( $N_{\alpha}$ ) is the ratio of clear space (open area) ( $I_{\alpha}$ ) to fish middle section  $H_f$ . Relative permeability is given by:

$$N_{\alpha} = \frac{I_{\alpha}}{H_f}$$

The index  $H_f$  is uncommon in the literature, but is often alternatively expressed as relative fish length, where  $H_f = KL$  where  $L$  = fish length. The value of  $K$  in **pre-larvae** and larvae of most Teleostei is 0.09 - 0.15, but for fingerlings with torpedo-shaped bodies it is 0.17 - 0.23, and for fingerlings with deep bodies, e.g. *Abramis brama* and *Blicca bjoerkna*, it is up to 0.3. For impermeable barriers the index  $N_{\alpha}$  is less than 1 (i.e. the transverse size of the fish is greater than the clear space size) while for permeable barriers it exceeds 1.

Permeable barriers include such devices as louvres (Bates & Vinsonhaler, 1957), suspended chains and ropes (Brett & Alderdice, 1958), air bubbling lines, line-curtains (floating segments of fishing line fastened to the bottom at 1mm intervals), nets permeable to young fish (mesh sizes 4-20mm, line thickness 0.5-1.5mm), water jets, pivots and cylinders (diameter 3-60mm), straight 10cm wide plates and L-shaped plates (Fig.37) (Pavlov & Pakhorukov, 1983). A comparison of results obtained in operating these devices identifies the following factors:

**A. The influence of the angle,  $\Theta$ , of the barrier relative to the axis of water flow.** The smaller  $\Theta$  is, the greater is the efficiency of fish protection. The optimum value of this angle for an air-bubble device is 11° (Kuragina *et al.*, 1978), while for louvres it is between 10-16° (Bates & Vinsonhaler, 1957).

**B. The influence of the approach flow velocity.** This was greatest when suspended chains, line curtains, air-bubble devices or louvres were used for fish protection. Studies have revealed a tendency for fish-diverting efficiency to increase as the value of  $V_{app}$  increases, but this is true only up to a certain velocity, after which protection efficiency declines. For air-bubble devices the optimum value of  $V_{app}$  is equal to the  $V_{\alpha}$  for the fish. Studies of impermeable fish-protection devices (see below) have shown that relative current velocity normal to the barrier,  $V_{nrm}$  is important, while studies on some permeable barriers, including air-bubbling devices, permeable nets and pivots, have indicated the range  $V_{nrm}/V_{\alpha} = 0.14-0.33$  to be most effective. However, further investigation of this important factor is required.

**C. The influence of flow velocity in fish-diverting devices.** An increase in flow velocity in the diversion channel,  $V_n$ , leads to an increase in the efficiency of fish-diversion. The ratio  $V_n/V_{app}$  in the diversion channel is smallest at optimum values of  $V_{app}$ . Calculations indicate that at optimum levels of fish-diversion in louver systems, the value of  $V_n/V_{\alpha}$  was about 1.4 when  $V_n/V_{nrm} \leq 5.3$ . For other devices tested  $V_n/V_{\alpha} = 1$  (except for those employing chains or line curtains) and  $V_n/V_{nrm} = 4.9-7.8$  (except when chains are employed).

**D. The influence of barrier permeability on the fish.** The relative permeability,  $N_{\alpha}$  of the structures tested varied between 1.0 and 21.8. The most complete data were obtained from tests of devices using nets, rods and louvres. Maximum efficiency was attained when  $N_{\alpha} = 1.3-3.0$ . The critical values of behavioural permeability, i.e. where fish pass actively through the barrier, are thus outside these limits. Behavioural

permeability is associated with fright/escape responses which depend on  $V_{app}$  and  $N$ , and on the width of the forebay immediately in front of the barrier. The gradual movement of fish towards the narrower forebay zone intensifies the fright response of the fish and concomitantly the search for an escape path from the critical situation. As a result the fish more often pass through the barrier. An increase of flow velocity mobilises the fish, intensifies the reaction to current and limits the search and escape response. An increase in the limits of  $V_{appr}$ , up to  $V_{cr}$ , increases the efficiency of the fish-protection device because of the decrease in behavioural permeability. However, increasing  $V_{appr}$  above  $V_{cr}$ , increases the probability of fish being carried through the barrier, i.e. physical permeability sets in, and this then begins to reduce protection efficiency. Thus, application of permeable tactile-hydraulic fish-protection devices is subject to both upper and lower flow velocity restrictions. In practice the effective operation of these devices is possible in only a rather narrow range of current velocities.

E. The influence of light. All permeable barriers have high protection efficiency while illuminated. However, in the dark there is a sharp decline in the efficiency of protection afforded by air bubbling with large mesh net panels, from 80% down to 30% (Pavlov & Pakhorukov, 1983). The efficiency of devices using chains and ropes is significantly enhanced by light (Brett & Alderdice, 1958). The illumination of a barrier during the night causes a fright response in fish and decreases protection efficiency by increasing the numbers passing through the barrier.

F. The shape and arrangement of the barrier. Barriers were either rectilinear and arched, with a fish diverting device on one side, or V-shaped, with a fish diverting device at the apex of the V. Investigations showed that the greatest efficiency was obtained when the elements of the barrier were placed in arched form, because this led to greater uniformity of current velocity ( $V$ ) along the barrier. The V-shaped arrangement led to lower efficiency because the fish became agitated when they reached the apex of the V and began to make jumps, thus increasing the number which passed through the barrier instead of into the diverting channel.

G. The comparison of efficiency between different types of permeable barrier. This aspect has proved difficult to evaluate. Most types of barrier have been assessed as diverting 70-95% of young fish in optimum conditions. However, some devices attain these levels of protection only when 50% of the total flow enters the diverting device, and then only during daylight hours, with fish lengths exceeding 150mm. Clearly the different types of device are not equivalent. Tests were made to determine the efficiency of different devices with barriers made of air-bubbles, chains and ropes, line curtains, rods, louvres, cylinders and L-shaped plates. A redistribution coefficient  $KR$ , was **calculated** and used to compare efficiencies;  $K = C_1/C_2$  where  $C_1$  is the fish concentration in a fish-diverting device, and  $C_2$  is the concentration in the water-intake device. This coefficient was determined for larvae 4-18mm long, in darkness, using barriers set in experimental chutes. Best results were obtained with arched barriers made of cylinders 40mm in diameter, arranged at intervals of 20-60mm. Under these conditions, when water discharge to the fish-diverting device was only 7% of the total flow,  $K$  was found to be 39.9. Using L-shaped plates arranged at intervals of 30-100mm, and with 11% of the flow going into the fish-diverter,  $K$  was 11.2. For all other types of barrier, even if 60-80% of the flow entered the fish-diverting device,  $K$  never exceeded 4.

H. The way in which permeable barriers work. This matter has so far attracted little attention. It was mentioned earlier that permeable barriers provide three main types of stimulus, visual, tactile and hydraulic. When illuminated, fish perceive all types of barrier visually and at optimum flow velocities they all divert the fish effectively. In darkness the barriers are perceived by virtue of other stimuli which they create, and here, hydraulic stimuli are of greatest interest. They are connected with sharp changes in flow structure i.e. boundaries between gradients, both longitudinal and transverse, and with changes in the direction of flow, and changes in the velocity pulse pattern of the current.

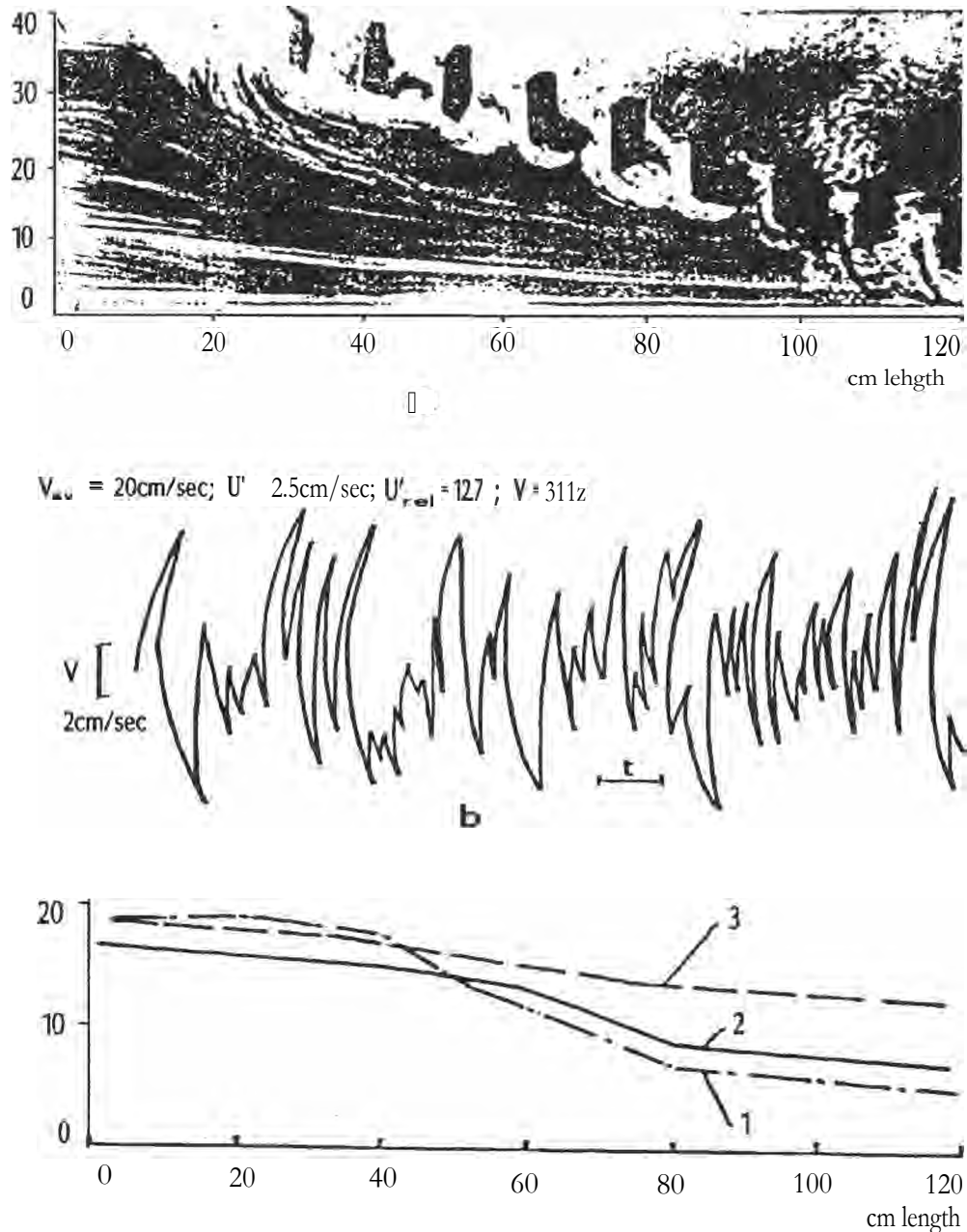

Figure 37.— a. Flow structure in front of a barrier composed of L-shaped plates at 8cm intervals, b. Pulses of current velocity 5cm in front of barrier in cross section:  $V_{av} = 20\text{cm/sec}$ ;  $t = 1$  sec;  $U' = 2.5\text{cm/sec}$ ;  $U'_{rel} = 12.7\%$ ;  $c = 3.1$  hertz, c. Lines of fish movement: 1. in light, 2. in darkness, 3. of dead fish.

Any object in a current sets up a local flow disturbance in front of it, *i.e.* it changes the pattern of the flow locally. The efficiency of fish-diversion in darkness depends upon the degree to which the barriers influence the flow pattern (Figs 36-38). Small disturbances have differing degrees of constancy depending upon the stability of the object setting up the disturbance. The lowest levels of continuous disturbance are set up by air-bubbles, and chains, ropes, line curtains and nets which vibrate freely in the current. Thus in darkness, when visual perception of these barriers is limited or non-existent, their efficiency is low. Tests have revealed that the barriers can be ranked in ascending order, according to the degree of disturbance

they create, *viz.* line curtains, nets, rods, louvres, and L-shaped plates, which created the maximum disturbance.

When a barrier is set at an acute angle with respect to the axis of water flow, the local disturbances which each element creates oblige the fish to move along the barrier from one element to the next, but this does not occur with dead fish or inanimate objects, thus confirming the role of behaviour in the phenomenon of fish redistribution along inclined barriers (*Figs.37 & 38*). In addition to local disturbances, inclined permeable barriers also create a transverse gradient in front of them. This also contributes to the redistribution of fish towards the diverting device.

The coincidence of the local disturbance zone with the points at which fish begin to exhibit obstacle avoidance responses in the dark, strongly suggests the hydro-dynamic nature of the stimuli received by the fish (Pavlov & Tyurukov, 1986). However, for smaller objects with fish 30-60 cm long, either the disturbances could not be detected, or they were detected, but failed to trigger the avoidance response. Apparently the fish detected these small objects only by contact.

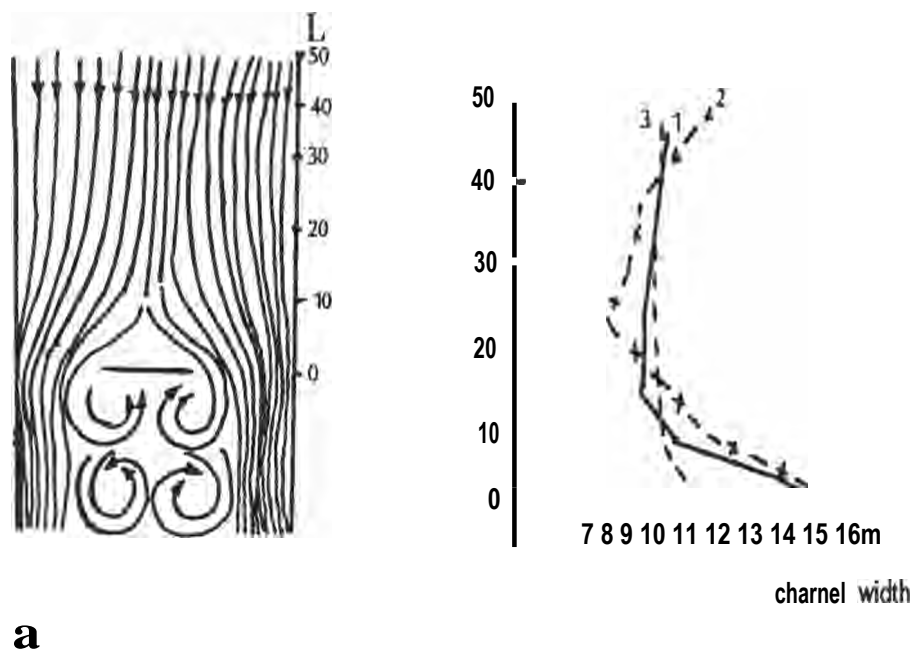

Figure 38.— a. Structure of flow around a plate 10cm wide, b. Lines of fish movement: 1. in darkness, 2. in **flow** disturbed by plate, 3. of dead fish.

The largest disturbances were created by plates and cylinders and when these were used to construct barriers in experimental chutes, up to 75% of fishes (6-17mm long) were diverted. The fact that fish can be oriented by means of hydrodynamic stimuli suggests that artificially created flow disturbances could be used to bring about redistribution of young drifting migrants.

#### 4.5.5 THE USE OF TACTILE-HYDRAULIC STIMULI WITH IMPERMEABLE BARRIERS

This combination covers a range of structures. An impermeable barrier presents wide possibilities for controlling fish behaviour, because the fish cannot pass into the intake devices at any current velocity. However, the strength of the stimuli generated in front of impermeable barriers forces fish to resist the current to the limits of their swimming capacities. Where these devices are used, protection can be achieved by behavioural as well as physical means. Some of the more important designs are assessed below.

##### 4.5.5.1 PRINCIPAL DESIGNS

Filtration fish-protection devices can be divided into two groups (Fig.39), those with and those without fish-diverting devices. The first group includes rotating belt nets, vertical and horizontal inclined plane nets, vertical and horizontal inclined rotating belt nets and conical devices. These devices can be further divided into those with barriers located perpendicular to the axis of the flow, and those with barriers located at an angle to the flow. The second group includes crib and frame filters, filtration dykes, plane screens, drum screens (with forced cleaning) and rotating belt nets. Among the more important filtration devices without diverters, are:

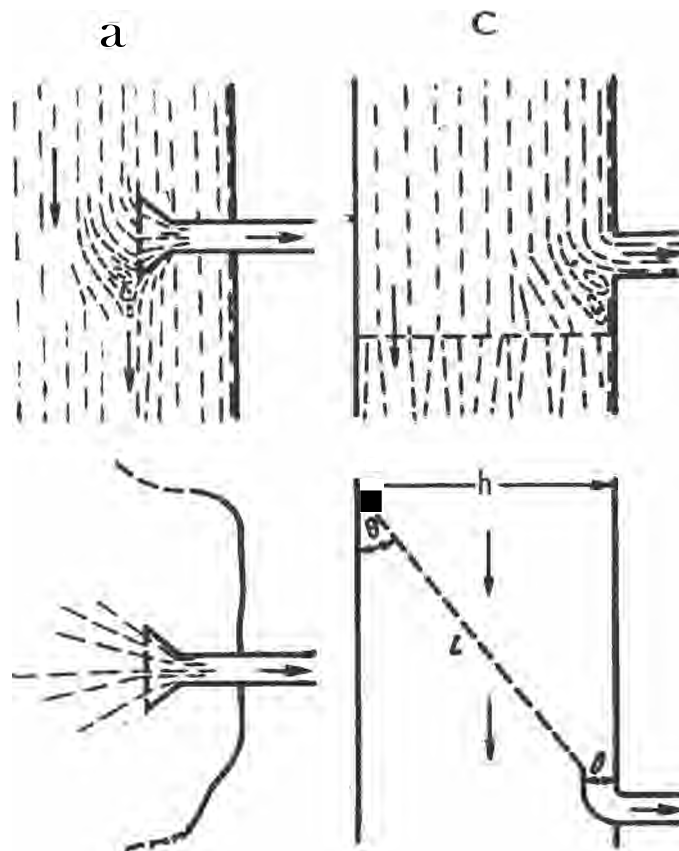

Figure 39.—Types of protecting structures: a. without diverting device, in rivers with pronounced currents; b. without diverting device in sluggish water-bodies; c. with diverting device and protective screen perpendicular to axis of water flow; d. with diverting device and protective screen set at an acute angle to the axis of the water flow.

A. Filters. Often filtration dykes made of heaped stones are used at water intakes for domestic and **industrial** purposes (Fig.40a,b). Crib and frame filters are boxes filled with pebbles, gravel, ceramsite, broken glass, bricks, or sundry other materials. Filled frames are placed in slots in the fish protection pier.

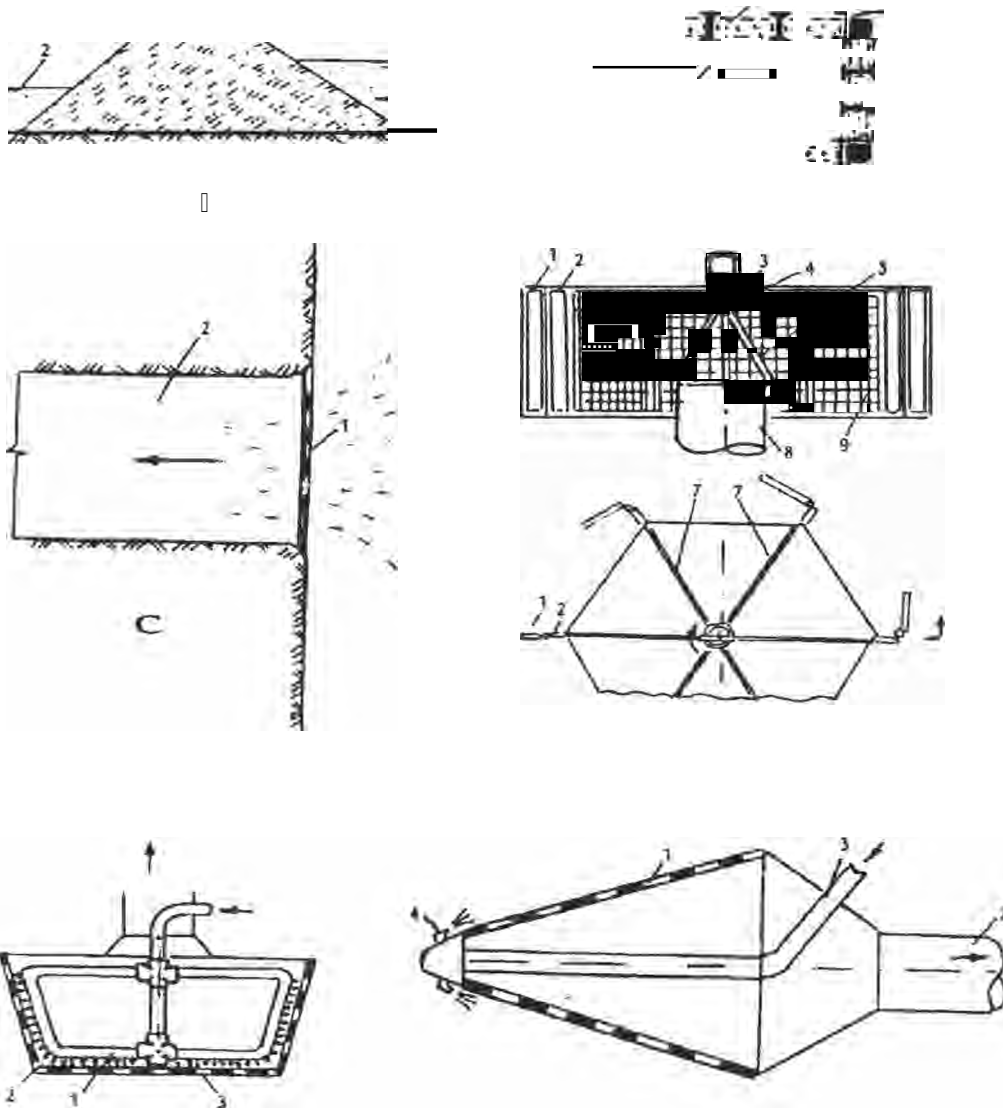

Figure 40.— Protecting structures without diverting devices: a. Filter dam: 1. filter dam, 2. water-intake canal; b. Device with gravel filters: 1. filter elements, 2. water-intake, 3. supporting structure; c. Vertical screen: 1. flat screen; d. Drum net with blade: 1. turning blade 2. stationary blade base, 3. bearing, 4. drum axle, 5. brackets, 6. stiffening ribs, 7. water intake, 9. screen; e. Drum net with forced **cleaning** (arrows indicate currents): 1. wash distributor, 2. washing jets, 3. filter panel; f. Fish-protection head: 1. perforated cone, 2. water intake, 3. wash pipe, 4. washer.

Because filtration units are expensive and their use involves cleaning, which is not easy, these types of filters are generally used only where water abstraction is small, up to about  $5\text{m}^3/\text{sec}$ . The velocity of the current in the filter pores is a very important index for fish protection. This velocity, in filter material 10-20mm in diameter, must not exceed the cruising speeds of the young fish under protection. Work is in progress to perfect filter designs by improving the cleaning system, decreasing flow through the filter, rationalising the arrangement of the protective screen, and choosing new filter materials. The designers have given much attention to the use of a material made from particles of inert filler with polyethylene,



known as poroelast. Frames and plates of poroelast are of low specific gravity and are easily cleaned. The average filtration **velocity**,  $V_{fv}$ , in **cm/sec**, in the pores of a poroelast filter is, according to Malevanchik & Nikonorov (1984):

$$V_{fv} = \frac{0.34Hd}{B}$$

where: H = the pressure head on the structure,  
 d = the mean particle size of the filler, and  
 B = the thickness of the filter element.

**B. Plate screens.** The plane of the screens can be flat or curved. They are set in frames built into fish-protection piers (*Fig.40c*).

**C. Self-rotating drums with blades.** These are hexagonal in section with the surface covered by a screen with mesh size of 1-2mm. The blades extend externally from the ribs, and consist of a fixed basal part and a manoeuvrable part hinged to this (*Fig.40d*). Rotation is brought about by the pressure of the current on the open blades. Cleaning is achieved by vortices formed along the blades as they open and fold with **rotation**, but the speed of rotation must exceed **0.1m/sec**. In a river flow these drums are used even for the protection of early fry. They achieve almost 100% protection when water throughput is **0.5-1.0m<sup>3</sup>/sec**.

**D. Drum screens with forced cleaning.** There are many variants of this device, but they fall into two main categories. In the first, the drum is stationary and the cleaning device rotates (*Fig.40e*). In the second the drum itself rotates around its axle. The current velocity through the net must not exceed 0.1-0.25m/sec and the water throughput can be up to **0.5m<sup>3</sup>/sec**. These are among the most widely used devices for both floating and stationary pumping stations.

**E. Protection heads washed by water jets.** *Fig.40f* gives details of a conical screen with external cleaning by water jets. The velocity of the current in the cell must not exceed 0.25m/sec and these devices are designed for throughputs of **0.025-0.5m<sup>3</sup>/sec**. Devices for throughputs of 0.25m<sup>3</sup>/sec (known as ROP-175) have been tested and are now installed in many low volume water-intakes in the Volga Basin and on the Ural River.

The more important fish-protection devices with diversion facilities are as follows:

**A. Vertical screens.** Essentially this comprises a plate screen with a cleaning device and a diversion channel. There are several arrangements, see *Fig.41a,b,c*. Cleaning is by means of a water jet, and a mechanism for moving the jet back and forth over the screen. Often the cleaning device is operated automatically when the screen becomes blocked. The distance between the nozzles of the water jet and the screen should not exceed 25cm, and the movement of the jet along the screen should not exceed 0.2m/sec, although the optimum speeds are lower than this, e.g. about **0.05-0.1m/sec**. The screen is located in a chamber at an angle of **10-25°** to the axis of flow, either in a straight line or a curve. These devices are recommended for water-intakes with flow rates of **1m<sup>3</sup>/sec** and faster. The discharge of water through the fish-diverting channel is usually less than 1-2% of the total volume throughput. These devices are widely used, some even built to cope with intake volumes of 160-330m<sup>3</sup>/sec, e.g. on the Donskoy main channel, the Mariyano-Cheburgolskaya irrigation scheme and the Kuban' irrigation scheme. Despite the use of nets with a mesh size of 2 x 2mm, these devices are really effective only for the protection of fry with lengths of 30-40mm or greater.

**B. Vertical belt screens.** The original design for this device, by Kharchev (1940), comprised a continuously rotating vertically located screen set at an angle to the water flow (*Fig.41d*). The net is driven by an electric motor and the fish-diverting device is a prolongation of the net screen. Several different **devices** of this

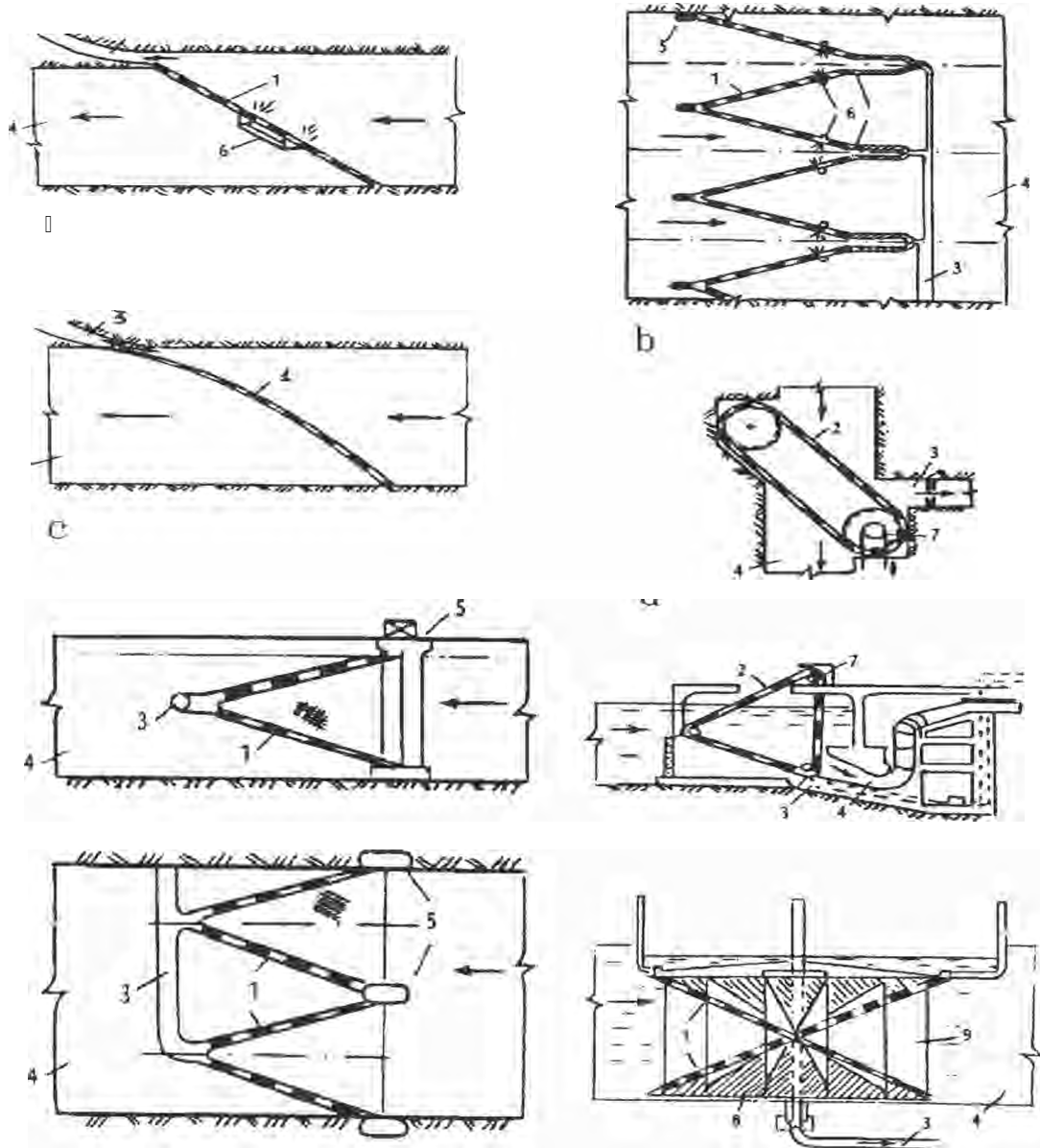

Figure 41.— Protection structures with diverting devices (arrows indicate direction of currents): a. flat screen with diverting device, b. vertical screens with V-shaped screen and diverter in each section, c. curvilinear screen, d. rotating belt screen located at an angle to the current, e. vertical rotating belt screen located perpendicular to the current, f. cone barrier with diverting device (lower diagram in plan view), g. conical multi-sectional fish barrier 1. screen, 2. rotating belt screen, 3. fish diverting device, 4. intake, 5. support piers, 6. washing jets, 7. drive of rotating screen 8. conical screens, 9. sectional partition.

type have been developed handling water flows of 3-20m<sup>3</sup>/sec (Bates, 1970; Bates & Van Derwalker, 1970; Bates, Murphey & Prentice, 1970; Bates, Murphey & Beam, 1971). The efficiency of these devices in protecting young Salmonidae (less than 30mm long) has reached 97-100%.

C. Horizontal belt screens, designed by Kiselev-Tsetskhladze (1981), have been tested under laboratory conditions. At an angle of  $29^\circ$ , the velocities of the approaching water flow were uniform along the entire length of the protective screen. The diversion efficiency for *Abramis brama*, 15–30mm long, and *Acipenser güldenstädti*, 30–40mm long, was 96–100% in trials. A model for industrial use, handling a water flow of  $19\text{m}^3/\text{sec}$ , has been constructed, Fig.41e.

D. Cone screens. These devices (Fig.41f,g) consist of truncated conical frames, covered by a cloth net which is swept clean by a water jet. A coarse screen may be placed in front of the cone to protect it from large sized debris. Cone screens have been tested under both laboratory and field conditions. The water throughput in the experimental models was  $0.05\text{--}0.8\text{m}^3/\text{sec}$ , and under optimum conditions they afforded 100% protection. Currently some cone devices have been installed at pumping stations where intake volumes are between  $1.5\text{--}20\text{m}^3/\text{sec}$  and tests show that they protect 90% of very small fish and up to 95% of larger juveniles.

Thus a range of devices for fish protection is available and installed, but the lack of field data, different methods of describing results, and differences between working regimes, make it impossible to make true comparisons between the different devices. The only comparisons which are valid are those based on small scale experimental tests (Pavlov & Pakhorukov, 1983).

#### 4.5.5.2 FISH BEHAVIOUR IN FRONT OF A BARRIER

The different signals received by fish from barriers placed either perpendicularly or obliquely to the axis of flow, produce radically different behaviour patterns. A perpendicular barrier stops the drift of the fish, forces them to resist the current, signals danger, but does not indicate the best way to a safe place, i.e. to the fish-diverting channel. Young fish enter an impasse zone and make search movements along the barrier, but in doing so can injure themselves on the barrier. By contrast, a barrier set obliquely to the flow gives danger signals to the fish, but also restricts the possibility of accidental movements and directly concentrates the young fish towards the fish-diverting channel. When the flow velocity is increased the fish remain in front of the oblique barrier only for a few tens of seconds, whereas, with a perpendicular barrier they can be trapped there for tens of minutes, or even for hours. The fishes in the reception chamber of the fish-protection device with an oblique screen have little time to avoid the screen and respond quickly.

Interpretations of kinematic observations of the behaviour of young Salmonidae in front of a louvre barrier led Bates & Vinsonhaler (1957) to propose a scheme of fish movement in front of a such barriers (Fig.42a). They deduced that the fish resist their drift towards the barrier with a velocity  $V_n = V_{app} \sin \theta$ , while the speed of their displacement,  $V_{dis}$ , in this situation is equal to  $V_{app} \cos \theta$ , where  $\theta$  is the angle of the barrier relative to the current and  $V_{app}$  is the velocity of the flow approaching the barrier. This correlation is possible if the fish resist the velocity perpendicular to the barrier screen.

Later interpretations, also based upon kinematics were made by Pavlov & Pakhorukov (1973, 1983). Their results suggested that fish behaviour in front of the barrier is controlled by two responses, reaction to current and avoidance reaction (Ray), the latter being a defensive reaction which prevents a fish from being damaged by the barrier. In the absence of a barrier, reaction to current causes the fish to align parallel with the lines of flow, and as a rule, to resist the current. If a fish, faced with an obstacle, sought only to avoid it, and nothing more, it would, ideally, simply resist the flow towards and perpendicular to the obstacle, i.e. it would resist the flow  $V_n$  in the scheme of Bates & Vinsonhaler (1957). However, faced with a barrier, and displaying both reaction to current and avoidance reaction, the fish behave differently. Their reaction to current is depressed to some extent, and the avoidance reaction becomes dominant. The direction of their resistance to the flow (Fig. 42b) diverges from the direction of the current by an angle  $\alpha$ . The fish's resistance swimming speed,  $V_{res}$ , is calculated as:-

$$V_{res} = V_n[\sin(\theta + \alpha)]$$

where  $V_n$  is the velocity of the flow normal to the barrier,  $\alpha$  is the angle of the fish's body position relative to the axis of water flow, and  $\theta$  is the angle of the barrier relative to the axis of the water flow. The displacement speed of a fish which resists the flow relative to a barrier ( $V_{dis}$ ) is calculated as:-

$$V_{dis} = \sqrt{V_{res}^2 + V_{appr}^2 - 2V_{res}V_{appr}\cos\alpha}$$

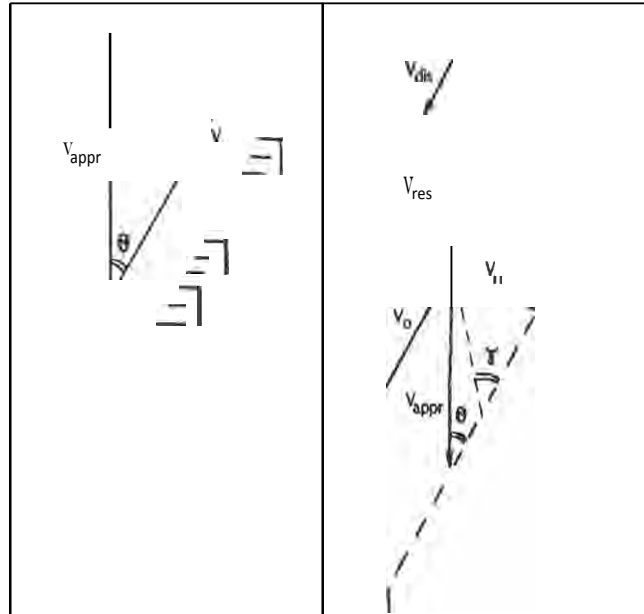

Figure 42.— Scheme of fish movement in vicinity of a barrier. a. after Clay (1961), b. after Pakhorukov & Kuragina (1978).  $V_{appr}$  = velocity of approach flow,  $V_n$  = velocity of flow normal to barrier,  $V_{\parallel}$  = velocity component parallel to barrier,  $V_{res}$  = resistance velocity of fish,  $V_{dis}$  = velocity of displacement of fish,  $\theta$  = angle of barrier relative to axis of water flow,  $\alpha$  = angle of fish's axis relative to flow,  $\chi$  = angle of fish's axis relative to barrier =  $(\theta + \alpha)$ .

This scheme of fish movement, incorporating behavioural responses, is to date, the most complete and precise description of the process of fish interaction with protective screens. It unites the hydraulic indices of protection devices and the swimming speeds of fish, which had earlier been compared only empirically, and thus concentrates choice on the conditions which will allow fish with known swimming speeds to enter fish diverting-devices voluntarily.

#### 4.5.5.3 THE EFFECT OF VARIOUS FACTORS ON DIVERTING EFFICIENCY

A. The angle  $\theta$  and the velocity of the approaching flow. These are the most important factors involved in the diversion process (Fig.43). A high level of diversion can be obtained at any angle of barrier placement, but the smaller the angle the better the conditions for concentration and subsequent diversion of the fish, and the greater the permissible velocity of the approaching flow. Under optimum conditions the velocity of an approaching flow can reach 2-3 $V_{cr}$ .

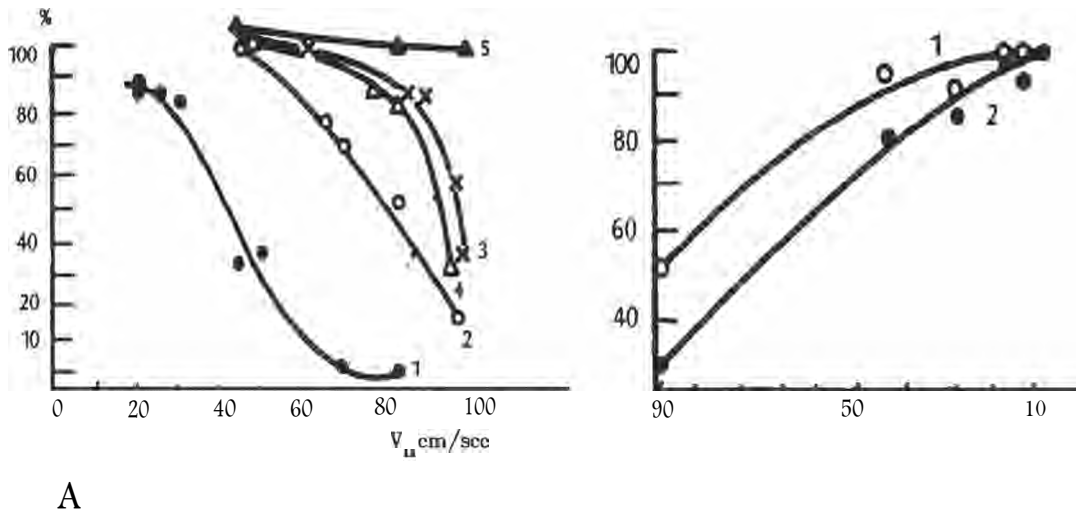

Figure 43.— The influence of the flow velocity normal to barrier ( $V_n$ ), and the angle of the barrier ( $\theta$ ) relative to the current, on the efficiency of fish protection: A. Cone devices: 1. cone with exterior diverter where  $\theta = 90^\circ$ ; 2. cone with exterior diverter where  $\theta = 15^\circ$ ; 3. cone with exterior diverter where  $\theta = 8^\circ$ ; 4. cone with exterior diverter where  $\theta = 5^\circ$ ; 5. cone with interior diverter, where  $\theta = 8^\circ$ . X axis =  $V_u$ , Y axis = % protection of fish. B. Vertical screen with diverter: 1. *Blicca bjoerkna* of 42mm mean length, 2. *Scardinius erythrophthalmus* of 43mm mean length. X axis = angle  $\theta$  of barrier, Y axis = % protection of fish,  $V_u = 80\text{cm/sec}$ .

B. The size range and species composition of the community under protection. Swimming performances and critical velocities increase with increase in fish length. As a result there is a concomitant increase in diversion efficiency (Fig.44) Thus species with higher average indices are generally better protected by impermeable barriers than those with lower indices.

C. Conditions for visual orientation. Investigations of different screen type protection devices revealed that at night when visual orientation was precluded or diminished, the capacity of fish to enter the diversionary flow was seldom diminished by more than 10%. Indeed in field tests, diversion efficiency at night could even be higher than during the day when the number of specimens manifesting the fright/escape reaction is increased (see Fig.45).

D. The velocity of the fish-diversion (transit) flow. An increase in the velocity of the diversion or transit flow ( $V_{div}$ ) leads to an increase in diversion efficiency for an approach flow ( $V_{appr}$ ) of constant velocity. An increase in  $V_{appr}$  requires an appropriate increase of  $V_{div}$ . In the devices tested, with a diversion efficiency of 100%, the volume of the transit flow was usually some 1-6% of the total flow passing through the device, and it never exceeded 11% of the total flow.

Thus in these devices it is possible to achieve high efficiency by varying different parameters. First at high values of  $V_{appr}$ , with low values of  $\theta$  and high values of  $V_{div}$ ; second at high values of  $\theta$ , with low values for  $V_{appr}$  and high values of  $V_{div}$ ; and third, at low values of  $V_{div}$  with low values of  $V_{appr}$  and  $\theta$ .

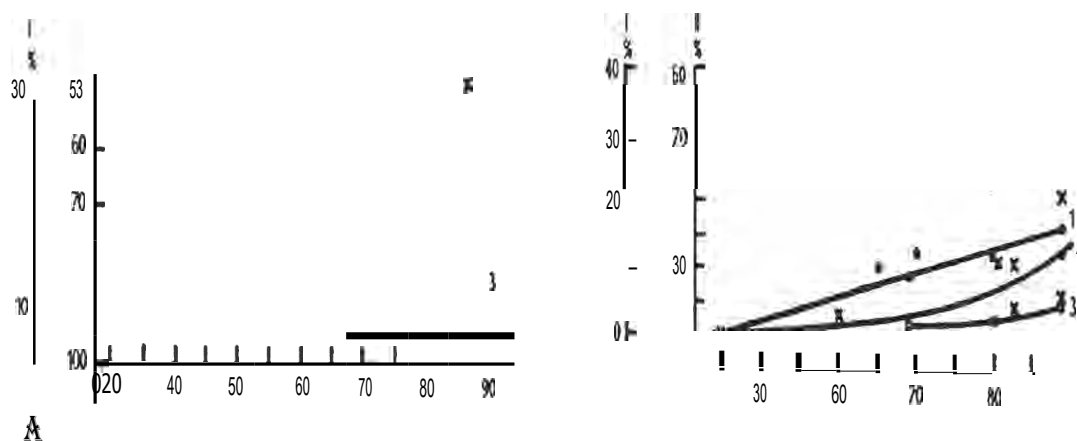

Figure 44.— Protection of a young *Rutilus rutilus* and b *Abramis brama*, both of different sizes, by a cone device on the IPdj River. 1. mean length 14.5mm, 2. mean length 19mm, 3. mean length 21.1mm, 4. mean length 27.2mm.  
X axes flow velocity ( $V_n$ ); Y axis I % trapped on device, II % protection

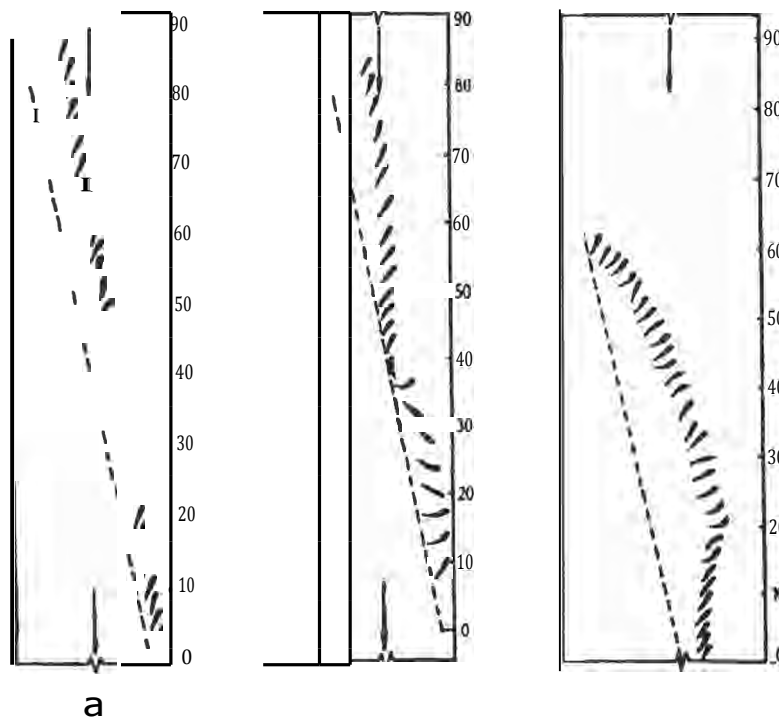

Figure 45.— Lines of fish movement along a barrier screen: a. typical pattern in light, b. the touching pattern in light, c. the touching pattern in darkness.

## 4.5.5.4 FUNDAMENTAL HYDRAULIC INDICES AND THEIR INTER-RELATIONSHIPS

The optimum hydraulic regime for fish protection can be calculated (Pavlov & Pakhorukov, 1983). Such calculations are based on biological and hydrological criteria, and correlate fish swimming performance with the hydraulic and technical parameters of a given fish-protection device. Two parameters of the device can be distinguished which influence the fish independently; the length (L) of the barrier (*i.e.* the screen) and the velocity of the flow in the fish diverting channel of the device ( $V_{fd}$ ). In addition there are two inter-related parameters; the angle of the barrier relative to the flow ( $\theta$ ) and the velocity of the flow approaching the barrier ( $V_{appr}$ ). The resultant of the latter parameters is given by:

$$= V_{appr} \sin \theta$$

where  $V_n$  is the velocity of the flow normal to the barrier.

The expression of all biological parameters (*e.g.* species, fish body length, state of development of sensory organs, capacity for orientation in a flow, swimming capacity and strength of the avoidance reaction) under high flow velocities, in front of a barrier, are reflected in two resultant indices. These are the fish's resistance swimming speed ( $V_{res}$ ) and the angle of the fish's body relative to the axis of flow ( $\alpha$ ). Three indices may also be derived; the velocity ratio in the meshes of the net screen ( $K_{net}$ ), the velocity ratio in the fish diverting device (K.), and the duration of a fish's drift along the barrier (T.). These indices permit the calculation of working regimes at which a protection device incorporating a diverter device, will exhibit a diversion efficiency of 85-100%. Some notes on these indices follow.

**A. The velocity ratio in the meshes of the net screen.** Data indicate that the effect of the interacting biological and hydraulic indices may be described by:

$$V_{res} = V_n [\sin (\alpha + \theta)]$$

In the most dangerous situation, when a fish touches the net, it must be possible for the fish to resist the current in the meshes of the net ( $V_m$ ), *i.e.*  $V_m \geq$  the normal component of the fish's resistance velocity, which in turn must be  $\geq V$ .

$$\text{thus } \frac{V_m}{V_c} = 1$$

where  $K_{net}$  expresses the ratio of the two velocities. The velocity  $V_m$  is related to the current velocity normal to the barrier net ( $V_n$ ) by the expression:

$$V_m = \frac{V_n}{p}$$

where  $p$  = the coefficient of net perforation, *i.e.* the open mesh area ratio (Pavlov & Pakhorukov, 1973).  $V_{crit}$ , the critical velocity, can be related to the resistance velocity  $V_{res}$  by the factor 'k'; thus  $V_c = kV_{res}$ ;  $k \geq 1$ , where  $V_{res} = V_n [\sin (\alpha + \theta)]$ . It therefore follows that:

$$K_{net} = \frac{(V_n/p)}{k V_n \sin (\alpha + \theta)}$$

$$= \frac{1}{k \sin (\alpha + \theta)}$$

Kinematic data show that at the maximum permissible levels, in the bulk flow, where  $\theta = 1$ , when fish still enter the diversion device of their own volition, young *C. ...* at the end of an experimental screen, resist the current when  $V_{cr} = 0.95V_{cr}$  ( $\theta = 0.95$ ), and the angle  $\theta$  is equal to  $24.7 \pm 3.2$ . At a given value of  $\theta$ ; when  $\theta = 15$ .

$$\text{Thus } K_{net} = \frac{0.95 \cos(24.7 + 15)}{1} = 0.6061$$

In these conditions, to resist flow at the mesh, where  $\theta = 0.533$ ,

$$0.6061 = \frac{\cos(24.7 + 15)}{0.533}$$

$\theta = 0.51$ , and thus  $V_{res}$  should be  $\leq 0.51 V_{cr}$

In practice, as fish may change their orientation when touching the net, to align themselves directly against  $V$ , the ratio  $K_{net}$  may be nearer to 1 in value.

**B. The flow velocity in a diverting device.** Researchers usually correlate the velocity of the diverting flow with the velocity of the approach flow according to a relationship  $K_d = V_{div}/V_{appr}$  (T... , 1973). To develop a general basis for different relative indices, a new index, the velocity ratio of a fish-diverting flow, was proposed, and is given by:

$$K_{div} = \frac{V_{div}}{V_{cr}}$$

$$\text{As } V_{cr} = \frac{V_{res}}{K_{div}} \Rightarrow V_{div} = K_{div} V_{cr}$$

$$\text{As } V_{appr} = \frac{V_{res} \sin \gamma}{\theta} \quad K_{div} = \frac{V_{div} \sin \theta}{V_{res} \sin \gamma}$$

$$\text{Thus } K_{div} = K_d \sin \theta$$

Theoretically the diverting flow has to ensure the carry-over of young fish which have passed to the end of the net screen on their own; in this case the velocity of the fish-diverting flow must not be lower than the critical velocity for the fish under protection; and thus

$$V_{div} \geq V_{cr}; K_{div} \geq 1.$$

**C. The duration of swimming in front of the net screen.** As mentioned earlier, the greater the flow velocity, the shorter the period over which fish can maintain station against the current. Sharp changes of swimming speed, from burst to cruising speed, occur over comparatively small time intervals, say 20-30 sec. Bearing in mind that the critical speeds are equivalent to 0.5-0.7 of the burst speeds (Pavlov & S... - ... , 1974; S... , 1975; Pavlov, 1979) one can assume that when faced with flows near  $V_{cr}$ , young fish will seldom be able to resist the drift towards the net for more than 20-30 sec. Hence it is necessary to calculate the duration for which the fish will be in the zone of the net screen under different hydraulic regimes. An index was proposed to help in determining this duration, the 'relative duration of drift along the screen in fish avoiding being pressed against the screen' =  $T_{dr}$  (Pavlov & K... , 1978). This index is calculated as follows:-



$$T_{dr} = \frac{L}{V_{dr}} = \frac{L}{V \sqrt{V^2 + V_{app}^2} - 2V_{rea} V_{app} \cos a}$$

where  $L$  is the length of the net screen;  $V_{dr}$  is the displacement velocity of the fish (see Fig.42) and  $a$  is the angle of the fish's long axis relative to that of the flow.

D. Experimental values of hydraulic indices. These were calculated by A.M.Pakhorukov, for the situation when the efficiency of fish protection is high, using data from tests of models of protection screens. For an efficiency of  $98.2 \pm 0.4\%$  the ratio  $K_{net}$  in the bulk stream =  $0.88 \pm 0.05$ ; the ratio  $K_{div}$  in the fish-diverting device =  $2.74 \pm 0.29$ ; the drift duration  $T_{dr}$  varied between  $4.2 \pm 0.5$  to  $18.4 \pm 1.7$  sec, depending upon screen sizes. At an efficiency level of  $89.1 \pm 1.1\%$  the value of  $K_{div}$  was  $2.42 \pm 0.15$ , and the value of  $K_{net}$  was  $1.17 \pm 0.07$ . A statistical analysis of experimental data indicated a high level of reliability for the indices  $K_{net}$  and  $K$ . Their values are significant at probability levels of 95% and above. Thus the proposed hydraulic indices  $K_{net}$  and  $K_{div}$  and  $T_{dr}$  connect behavioural characteristics with the hydraulic characteristics of the protection devices. The use of the maximum permissible values for these indices ensures efficiency, with a high level of fish protection. These indices also allow working efficiency to be forecast according to the indices of current reaction which can be determined in simple field experiments.

#### 4.5.5.5 FISH-PROTECTION DEVICES WITH AND WITHOUT DIVERSION

The decision as to which particular type of protection device to use is made largely on the capacity of the fish to resist the filtering flow and the presence or absence of a transit flow in the device under consideration.

A. Protection devices without diversion. These devices can be considered when there are natural transit flows. There is a great difference between water-bodies with rapid and slow flows (Fig.39). In water bodies with a slow outflow, e.g. lakes and reservoirs, the natural conditions for the diversion of fish under protection are absent. The fish tend to remain in a water-intake current for a long time and may become fatigued and pressed against the protective screen. They then have to make their own way off the screen and away from the water-intake zone. Because of this, the intake velocities have to correspond with the lower cruising speeds of the fish. It has to be remembered that the upper limit of cruising speed, which can be sustained for about an hour, is only 1-4 lengths/sec. Hence, in order to create conditions in which a fish can swim away, an enormous area of filtration screen is required, to permit the necessary volume intake in unit time, and this can be done only in a very limited number of cases.

The choice of permissible filtration velocities depends not only on the swimming performance of the fish, but also on the correlation between the transit flow and the water-intake flow. In most cases the filtration (intake) velocities may not exceed the cruising speed of the fish, and the transit ones have to exceed the critical velocities of the fish. In these circumstances the distance from the net screen to the transit flow should not exceed 20cm in general. Because of these considerations, protection devices without fish diversion can be used successfully only where transit flows occur in the vicinity of the water-intake zone, and where intake velocities correspond to the cruising speeds of the fish. In practice it is extremely difficult to find these conditions, hence the application of this type of device is limited.

B. Protection devices with diversion facilities. These devices can be used in a range of water-bodies. The protective screen in these devices can be placed either perpendicularly or at an acute angle to the water flow (Fig.39). Placing the screen perpendicular to the flow makes it difficult for the fish to get into the diversion device. They are confronted by the filtration screen for a long time, and because of this the filtration velocities should not exceed the cruising speeds of the fish. However, decreasing the angle of the barrier screen relative to the axis of the water flow improves conditions for diversion. In this situation the

behaviour of the fish tends to remove them from the screen and into the transit flow. In addition it becomes possible to wash off any trapped fish from the screen. The angle at which the screen is set is of great importance for correlating the velocity of the approaching flow velocity and that of the filtration flow. In the interest of economics it is usually desirable to remove water at high velocities, but with a filtration barrier set at 90 this is impracticable. By decreasing the angle of the net screen relative to the water flow, without changing the filtration velocity, one can increase the velocity of the approach flow.

Table 3 compares the uses of these two groups of protection devices. It is clear that protection devices using a protective screen and incorporating a diversion facility are the most effective and are of wide-spread application.

TABLE 3. CONDITIONS FOR USING FISH PROTECTION DEVICES WITH AND WITHOUT DIVERSION

Design of FPD device	Character of transit flow: $V_{tr}$	Type of water body body	Conditions for FPD use	
			$V_m$	$V_{appr}$
Without diversion	Natural: $V_{tr} > V$	Reservoirs, lakes, river banks, bays	none	none
	Natural: $V_{tr} > V_{cr}$	Rivers	$V_{crit}$	
With diversion screen at 90° to flow	Artificial: $V > V_{cr}$	Any type	$V_{crit}$	
Screen at angle less than 90°	Artificial	Any type	$< 1V$ ,	0.7-3V,

At present three different schemes for the arrangement of the net screen are used. The screen may be horizontal with flat or rotating screens, it may be vertical with plane or rotating nets, or it may be three dimensional, *e.g.* having conical nets. The three-dimensional type allows shortening of both the screen length and the protection device, and permits the section, of the diverting channel to be significantly reduced. While decrease in the length of the protective screen is important, it also has biological significance, since with a long screen the time the fish spend in front of it is increased, *i.e.*  $T_{ar}$  is large. Further with a large protective screen the structure of the transit flow deteriorates.

A flat screen is made up of sections in frames, which are placed one after another in the grooves of a supporting structure. With an increase of screen length the sections of the frame and supporting structures need to be increased, and these often protrude in front of the screens by 1-5cm. With an increase in size of the supporting elements, adjacent hydraulic conditions are altered, and the conditions for the lateral movement of fish along the screen deteriorate. By contrast, rotating belt screens lack grooved protruding supports, and the amount of metal used in them is small. Rotating belt screens offer other advantages as well. Higher approach flow velocities are permissible because if fish become trapped on the screen this occurs only briefly, before the trapped fish are carried along to the diverting device.

In summary, devices with three-dimensional screen arrangements are the best, followed by those with rotating belt screens. Flat screens suffer from the greatest limitations.

#### 4.6 THE SUITABILITY OF DIFFERENT FISH-PROTECTION METHODS

Successful fish protection depends upon a thorough knowledge of fish ecology and behaviour. Measures based on such knowledge should be applied, especially at water-intakes involved in large scale abstraction, while protection devices based solely on physical principles may only be applied on intakes with low flow rates. Devices based on behavioural principles are the most widely used, and depend upon the control of fish behaviour by means of stimuli to divert fish away from the water-intakes.

Methods based upon the use of repellent stimuli are common and the search for optimum operating regimes for barriers providing repellent stimuli could help to reveal some general principles for controlling fish movement in flowing water. In overall terms the efficiency of operation depends upon flow velocity ( $V_5$ ), the optimum value for which is determined by the quantitative indices of the current reaction ( $R_6$ ), the angle of the barrier ( $\theta$ ), and by the strength of the fish's overall response ( $R_b$ ) to the stimulus received from the barrier, such that:

$$V_n = f R_{th}; \quad ; R_b$$

A high level of fish protection can be achieved with any angle of barrier disposition, but with a decrease of  $\theta$  down to certain limits, the conditions for the consecutive concentration and diversion of the fish are improved, and the **permissible** velocity of the approach flow is increased. Flow velocities normal to a barrier ( $V_n$ ) must be constant, independent of the angle  $\theta$ .

The action of different barriers is determined by the strength of response to the stimulus offered. Barriers may be either permeable or impermeable but in both cases the defensive reaction, whereby fishes seek to avoid contact with the barrier, is combined with both the search (for a safe place) reaction and the reaction to current:-

$$R_b = f R_w; R_m; R_s$$

where  $R_b$  is the resultant strength of the combined response to the barrier stimulus,  $R$  is the strength of the avoidance reaction and  $R_s$  is the strength of the search reaction.

The regular way in which these indices change in relation to changes in flow velocities are indicated in Fig.46.  $R_s$  has a **definite** initial level. When there is no current there are no limitations in space for the manifestation of this reaction. When the current velocity exceeds the threshold velocity ( $V_{thr}$ ), the search reaction against the current becomes limited. A velocity increase, up to the cruising speed ( $V_c$ ), in the limited space of an intake-chamber, leads to an increase in discomfort and in consequence to an increase in the strength of the search reaction,  $R_s$ . At the same time, when the current velocities exceed  $V_{thr}$  the reaction to current increases in strength and its mobilising action, manifested as a movement against the current, begins to suppress the search reaction. When current velocities are close to the critical ones,  $R_s$  approaches zero, and  $R_{th}$  reaches its maximum. The search reaction may lead to a completed passage through a barrier, but the frequency of this depends upon barrier permeability and naturally falls to zero when the value of  $N_{perm}$  reaches unity in an impermeable barrier. The strength of the avoidance reaction  $R_{av}$  depends upon the strength of the stimulus and reaches its maximum in front of an impermeable barrier.

The values of these indices influence the efficiency of different kinds of barriers (Fig.47) outside the zone in which the current velocity is close to  $V_c$ . In the zone below  $V_c$  the fish can pass through permeable barriers by virtue of the search reaction, and in the zone above  $V_{cr}$  they can also do this because the flow velocity exceeds the fish's swimming speed. When impermeable barriers are used the fish seek to avoid being trapped against the barrier and the strength of their response in this extreme situation is

maximum. Therefore, under such conditions, a higher velocity normal to the barrier ( $V_n$ ) is permitted. At impermeable barriers its optimum values are  $V_n = 0.5V_{cr}$ , whereas for the permeable barriers tested  $V_n = 0.14-0.33 V$ . This indicates that in the first case a more rigid regime of fish control is admissible.

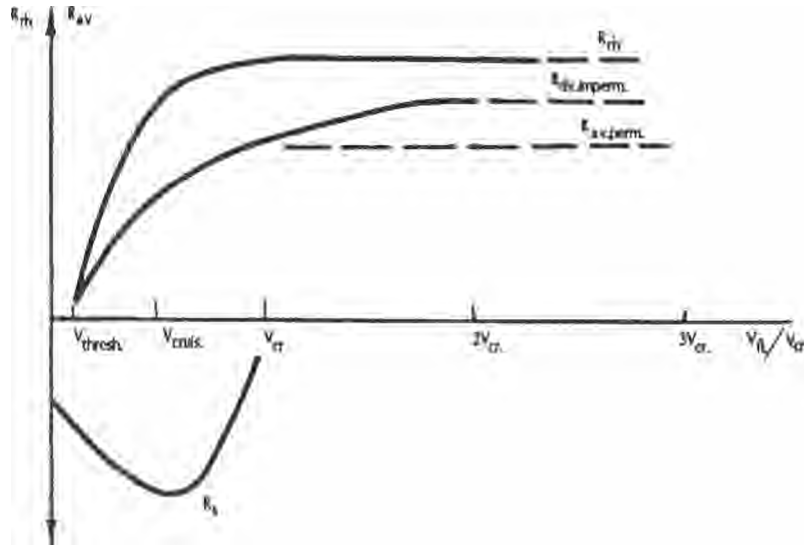

Figure 46.— The influence of water flow on the main behavioural reactions of fish in front of a **barrier**.  $R_{av}$  = avoidance reaction,  $R_{av,perm}$  = avoidance of permeable barrier reaction,  $R_{av,imper}$  = avoidance of impermeable barrier reaction,  $R_{th}$  = reaction to current,  $R_s$  = search reaction,  $V_{thresh}$  = threshold current velocity,  $V_{crit}$  = fish cruising speed,  $V_{cr}$  = critical current velocity,  $V_n$  = flow velocity, N.B. where there is a lack of experimental data on fish behaviour, velocities are shown by broken lines.

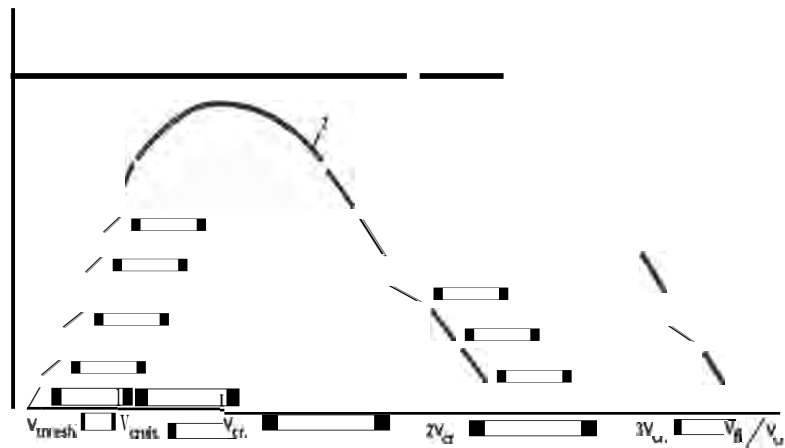

Figure 47.— Model of the dependence of fish-diversion on flow **velocity**, 1. protective device with impermeable barrier, 2. protective device with permeable barrier,  $n$  = diversion efficiency,  $V_{th}$  = threshold current velocity,  $V_{crit}$  = fish's cruising speed,  $V_{cr}$  = critical current velocity,  $V_n$  = flow velocity, N.B. the velocities for which there is a lack of data on fish diversion are shown by broken lines.

The functional relationships described will become more precise following future investigations, particularly as permeable barriers will be improved. At the present time impermeable barriers are highly reliable in controlling drifting fish and have no limitations in the lower current velocity ranges, but with permeable barriers, increases in flow velocity increase the probability of fish entering water-intakes.

The other parameters of protection devices apparently have similar quantitative values. For example, the velocity,  $V_{div}$  in fish-diverting devices at impermeable barriers is about 5V., while at permeable barriers it is about 4.9-7.8 V. In both cases the barrier length should not exceed 20-30m, and also in both cases, the equalisation of velocities along the length of the barrier is desirable. The method of achieving this latter end is normally to use curvilinear barriers (*Fig.41c*). The types of devices recommended for different rates of water abstraction are given in Table 4.

The problem of choosing a method for diverting the fish out of water-intake zones can be resolved according to the design of the system and the character of the water-body. However, in general, if early fry have to be diverted, the entrance to the diverting (transit) flow has to be placed in the diverter operating zone. The velocity of the diverting flow has to exceed the critical current velocity for the fish under protection ( $V_{div} >$  In the absence of a natural transit flow, *e.g.* in reservoirs, lakes and on stretches of rivers with slow currents, it is necessary to use diverters with **artificial** fish diversion flows; ejectors, centrifugal pumps, air-lift pumps, vacuum pumps and rotor pumps are used for this. These are selected with a view to ensuring the maximum viability of the fish (Pavlov & Pakhorukov, 1983; Malevanchik & Nikonorov, 1984).

TABLE 4. RECOMMENDED TYPES OF DIVERTER FOR WATER INTAKES OF DIFFERENT CAPACITIES

Type of FPD	Water Intake Capacity in m <sup>3</sup> /sec					Length of fishes protected
	<0.5	0.5-1.5	15-5.0	5-10	10-300	
Net drum in transit flow	+	-	-	-	-	>10mm
Washed fish protection head in transit flow	+	-	-	-	-	>10mm
<b>Self-rotating</b> drum with blades in transit flow	+	+	-	-	-	<b>&gt;10mm</b>
Umbrella-shaped head	+	+	-	-	-	>5mm
Vortex diverter with central fish diverting device	+	+	-	-	-	<b>&gt;10mm</b>
Cone net diverter	+	+	+	+	+	<b>&gt;10mm</b>
Vertical fish <b>concentrator</b>	+	+	+	+	+	<b>&gt;10mm</b>
Vertical plane net	+	+	+	+	+	230-40mm

## 5. CONCLUSION

The first stage in ensuring natural reproduction in diadromous and semi-diadromous fish is the provision of a pathway for them, through dams, to the spawning grounds. This requires the construction of fish-passes, satisfactory designs of which are available, and those constructed in the USSR during the past 15 years have proved effective.

The next, and no less important stage, is to preserve spawning activity *per se*. To this end, in the USSR, natural spawning zones have been protected by structures which control water level, mainly for the semi-diadromous species. Artificial spawning grounds have also been built in suitable areas. By spreading pebbles and maintaining a suitable current velocity and water depth, these can attract Acipenseridae, and have been constructed *e.g.*, on the Volga and Kuban' Rivers. Artificial panels with surfaces which mimic those of natural spawning grounds are also being tested. Such panels are placed at selected sites, and removed and cleaned after each spawning (Malevanchik, 1980; Nikonorov & Malevanchik, 1982).

The next important stage is to ensure the success of the seaward drift migration of young fish. To protect farm reared Acipenseridae from predators, the young are carried in special vessels directly to the estuaries. Young Salmonidae, by contrast, are released directly into the rivers and make their own way to the sea. Special techniques are employed at the hatcheries to imprint the defensive reaction (Nikonorov, 1984; Zhuykov, 1986).

The tasks of ensuring the seaward drift through dams, and of preventing the young fish from being drawn into water-intakes, still prove difficult. In the USA and many other countries the devices and measures employed to these ends are directed mainly at protecting drifting Salmonidae. These are 10-30 times larger than the young fish which require protection in the USSR, where specimens just 5-20mm long undergo drift migrations. Significant progress has been made with devices which afford high levels of protection at intakes removing water at rates of 10-30m<sup>3</sup>/sec. Where intake rates are higher, effective protection is still only available for specimens more than 30-40mm long.

Over several decades researchers have concentrated their efforts on screening devices, because impermeable barriers are too cumbersome and expensive for intakes of high capacity. Thus results from the first industrial vertical fish concentrators are eagerly awaited, as is the further development of screen devices, and of methods not using barriers at all.

Since even the most effective protection devices are of little use in protecting fish less than 10-12mm long, protection of the earliest stages can be achieved only by engineering manipulations based on knowledge of the ecology of individual species. In some cases these measures may be effective even for the protection of fish eggs, but protection methods founded upon an ecological basis are not yet widely employed. Ideally, the search for a fish-protection system at a water intake should begin with a consideration of devices of this type. For the best protection of later developmental stages it is envisaged that future measures will be founded upon both ecological and behavioural principles.

Ensuring the safe passage of drifting fish through reservoirs and dams is another problem, and involves not only those species which migrate to the sea, but also several species which spend their entire lives in rivers. In order to help choose strategies which will ensure that healthy fish stocks are maintained in rivers and lakes, where impoundments have retarded water flow, one needs to know more about downstream migrations in different systems. Drift migrations occur in all water bodies with controlled water-exchange so far studied. Usually, the length of the drifting fish does not exceed 120mm. Differences in the species composition of migrating communities, and of their size, and that of the individuals they comprise, are connected with the morphology of the bed of the system, and with the quantities of water removed from it.

Migrations are governed by the distributions of fish in water-bodies, and by seasonal variations in current velocities, with some water-bodies changing seasonally from lentic to lotic and *vice versa*. In water-bodies with strong surface flow, migrations usually occur in early summer, while in water-bodies with near-bottom flow (e.g. the Volga Reservoirs) migrations occur all year round and are typical of fish inhabiting the bottom of the open water zone (Coregonidae, Osmeridae & Percidae). Fish move to lower water levels as they grow bigger, and also with the advent of cold weather, which helps explain the seasonal variations in their migration patterns and distribution by size.

The largest migratory populations belong to species living in the pelagic zones of reservoirs, e.g. *Morpha spirinchus* and *Osmerus eperlanus*, and these provide the bulk of the migrating fish each year. These are followed by species inhabiting the sub-littoral and benthic zones, *Abramis brama*, *Acerina cernua*, *Alburnus alburnus* and *Perca fluviatilis*. The smallest populations are those of species inhabiting the near-bank vegetated areas, e.g. *Blicca bjoerkna*, *Esox lucius*, *Rutilus rutilus*, *Scardinius erythrophthalmus* and *Tinca tinca*. These specific distributions are influenced by a decreasing gradient in the influence of run-off currents and a corresponding improvement of conditions for orientation towards the banks. The pelagic fish have the highest migratory coefficients ( $K = 0.15-0.24$ ) which explains why their stocking in reservoirs, to increase fish yield, has generally been unsuccessful.

It should be noted that the large plankton-eating food fish are almost absent from reservoirs, while in large lakes in the same regions, these species comprise up to 43.3% of the total annual catch (Kuderskiy, 1970; Shimanovskaya *et al.*, 1983). Analyses of catches on 10 reservoirs on the Volga, Kama and Don Rivers, showed that the number of pelagic species in catches was significant only in the Tsimlyanskoye (*Abramis ballerus*, *Pelecus cultratus* and *Stizostedion lucioperca*), Rybinskoye (*Abramis ballerus* and *Stizostedion lucioperca*) and Verkhnevolzhskoye (*Stizostedion lucioperca*) Reservoirs. These were distinguished from the other reservoirs by having comparatively slow throughputs, with respective water-body turnovers of 1.0, 1.3 and 2.6 times a year. These are the reservoirs where water has the longest residence times, and the ones in which the process of drift migration is most retarded (Pavlov *et al.*, 1981; Pavlov, 1986).

Unlike the situation in most lakes, the open water zones of reservoirs, with their high rates of water exchange, are best exploited by small short-lived pelagic species. In many reservoirs of the European USSR these are *Clupeonella delicatula* and *Osmerus eperlanus eperlanus*. The high migratory coefficients of pelagic species in the USSR lead to mass mortalities during their passage through the turbines of hydro-electric power stations, and this, coupled with the irreversible character of their migrations, quickly leads to the depletion of their resident populations in reservoirs with near-bottom run-off. The degree of this influence is largely determined by the residence time of water in the reservoir.

Most rivers of significance for fisheries purposes are already regulated and suffer from multiple-user impacts. What then are the chances of preserving fish migrations under such circumstances, and what are the possibilities of utilising inland water-bodies for fisheries in the future?

In order to maintain populations of diadromous and semi-diadromous fish we are obliged to conserve at least a part of their spawning grounds, as well as ensuring their migrations up and downstream. From an ecological, and indeed an economic point of view, the advisability of such action is beyond question. Further, an appropriate technology for this already exists. However, the construction of dams should not be permitted in the lower reaches of rivers since in such positions they have greater ecological consequences for migratory fish than if placed farther upstream. Hydrological projects do not in general threaten the existence of those species which spend all their lives in rivers; nevertheless they do not promote the development of maximum population sizes in some species in reservoirs. Therefore the restoration of full migratory cycles in such cases is dictated by the interests of fisheries, but is only one of several possible strategies for increasing reservoir fish yield. Other strategies include attempts to make the throughflow

conditions of reservoirs approach those of a natural lake; attempting to prevent fish drift by the use of fish-protecting devices; and, regular stocking with large fingerling (10-15cm) of pelagic species.

The development of these strategies is an important and urgent scientific and technical task. It is only by identifying, developing and applying measures to support fish migration and reproduction that inland fisheries reserves can be fully preserved.



## REFERENCES

- Arnold, G.P, Rheotropism in fishes. *Biol. Rev. Camb. Philos. Soc.*, 49(0515-76).  
1974
- Avakyan, A.B., V.B. Saltankin and V.A. Sharapov, Reservoirs. Moscow, Mysl', 325p. (in Russian).  
1987
- Balyk, M.G., and D.V. Radakov, Experience of underwater observations on fish at the dam of the  
1969 Volgogradskiy hydraulic project. *In Marine underwater investigations*. Moscow, Nauka,  
pp.33-9 (in Russian).
- Baranyuk, G.V., and O.B. Tikhomirov, Observations on the water-intake and wasteway devices of the  
1969 Ali-Bayramlinskiy hydroelectric power station as related questions of fish-protection.  
*Izv. Gos. Nauchno-Issled. Inst. Ozem. Rechn. Rybn. Khoz.*, 65:299-317 (in Russian).
- Barekryan, A.Sh., Hydraulic calculations on fish-passes. A manual for students. Erevan (in Russian).  
1980
- ..... Ways to increase the efficiency of fish-passes. *In Hydraulics and engineering hydrology*,  
1981 Kalinin, Kalinin Polytechnical Institute, Kalinin State University (in Russian).
- Barekryan**, A.Sh., and A.I. Lupandin, The pattern of the attracting flow in the tailwater of a dam and the  
1985 calculation of its parameters for the location of fish-passes. *Sb. Nauchn. Trud. Gidroproek.*,  
(99):116-26 (in Russian).
- Barekryan, A.Sh., and M.A. Skorobogatov, The investigation of hydraulic operating conditions for  
1982 mechanical fish-lifts of medium height dams. *Sb. Nauchn. Trud. Gidroproek.*, (8086-90  
(in Russian).
- ..... Determination of flow structure in the fish attraction zone at the mouth of the  
1985 collection gallery. *Sb. Nauchn. Trud. Gidroproek.*, (99):135-40 (in Russian).
- Barus, V., *et al.*, Downstream fish migration from two Czechoslovakian reservoirs in winter conditions.  
1984 *Folia Zool.* 33(2):167-81.
- Bates, D.W., Diversion and collection of juvenile fish with travelling screen. *Fish. Leaflet. U.S. Fish Wildl.*  
1970 *Serv.* (633): 6p.
- Bates, D.W., E.W. Murphey and M.G. Beam, Travelling screen for removal of debris from rivers. *NOAA*  
1971 *Tech. Rep. NMFS (Spec. Scl Rep. Fish.)* (645): 6p.
- Bates, D.W., E.W. Murphey and E.F. Prentice, Preliminary designs of travelling screens to collect juvenile  
1970 fish. Design and operation of a cantilevered travelling fish screen (model V). *Spec. Scl*  
*Rep. U.S. Fish. Wildl. Serv. (Fish)*, (608):6-15.
- Bates, D.W., and J.G. Vanderwalker, Preliminary designs of travelling screens to collect juvenile fish.  
1970 Travelling screens for collection of juvenile salmon (models I and II). *Spec. Scl Rep. U.S.*  
*Fish. Wildl. Serv. (Fish)*, (608):1-5.

- Bates, D.W., and R. Vinsonhaler, Use of louvres for guiding fish. *Trans. Am. Fish. Soc.*, 86:38-57.  
1957
- Birknek, O.A., and Z.I. Kipper, Fish-passes. Moscow, Pishchevaya Promyshlennost 53p. (in Russian) .  
1960
- Bolshov, A.M., Experience with fish-protecting structures in use at irrigation pump stations. Moscow,  
1967 12p. (in Russian) .
- Brett, J.R., and D.F. Alderdice, Research on guiding young salmon at two British Columbia field stations.  
1958 *Bull. Fish. Res. Board Can.*, (117): 75p.
- Burns, J.W., Fish screens. *Inland Fish. Manag.*, Sacramento, Calif. Dept. Fish and Game, pp.156-61.  
1966
- Chikova, V.M., The species and age composition of fishes in the tailwater of the Volzhskaya V.I.Lenin  
1968 hydroelectric power station. *Tr. Inst. Biol. Vnutr. Vod. ANSSR*, 16(19):135-40  
(in Russian).
- Clay, C., Design of fishways and other fish facilities. *Department of Fisheries*, Ottawa, 301p.  
1961
- Collins, G.B., and C.H. Elling, Fishway research at the fisheries engineering research laboratory. *Circ.*  
1960 *U.S. Fish. Wildl. Serv.* (98):17p.
- Collins, G.B., et al., Effect of fishway slope on performance and biochemistry of salmonids. *Fish. Bull.*  
1962 *U.S. Fish. Wildl. Serv.*, 63(1):221-53.
- Demchenko, M.F., On the quantity and species composition of young fish drawn into the water-intake of  
1973 the Kremenchugskiy hatchery, Kiev, pp.101-5 (in Russian).
- Denisov, P.A., Fish-protection devices at the water-intake and spillways of thermal power stations. *Tr.*  
1965 *Koordinat. Soveshch. Hidrotekh.*, 24:25-38 (in Russian) .
- Derzhavin, A.N., Fisheries and agriculture of the Trans-caucasian region. Materialy k poznaniyu russkogo  
1915 rybolovstva. Petrograd, 4(12):38-62 (in Russian)
- Dyuzhikov A.T., On the expediency of fish passage into the headwaters of the Volga River hydraulic  
1958 projects. *Rybn. Khoz.* (10):33-8 (in Russian) .
- Ebel, W.J., Review of effects of environmental degradation on the freshwater stages of anadromous fish.  
1985 *In* Habitat modification and freshwater fisheries. Proceedings of a symposium of EIFAC,  
edited by J.S.Alabaster. London, Butterworths, pp.62-79 .
- Filchagov, L.P., The scientific bases for choosing fish protective devices at the large water-intakes of  
1980 irrigation systems. *In* Synopsis of theses of diss. cand. biol. sci., 24p. (in Russian).
- Filchagov, L.P., and A.M. Bolshov, The 'hood' type of fish-protection device. *In* Raspredelenie i  
1980 ekologicheskie sposoby zashchity molodi ryb. Moscow, pp.174-90 (in Russian).
- Filchagov, L.P. et al., On the problem of fisheries use of irrigational systems. *Rybn. Khoz.*, Kiev, 39:57-63  
1985 (in Russian).

- Flick, W.A., Effectiveness of three types of barrier panels in preventing upstream migration of fish. *Progr. Fish-Cult.*, 30(2):100-3.  
1968
- Friez, G., and F.W. Tesch, Aufenthalt der Fische im Bereich von Stauwehren. *Schweiz. J. Hydrol.*, 27:257-72.  
1965
- Gasanov, G.I., Studies of fish-protecting devices used at water-intakes in the Azerbaijan Soviet Socialist Republic. In Fish-protecting devices at water-intakes. *Zb. Nauchn. Trud. YuzhNIIGIM, Novocherkassk 1981*, 59-93.  
1981
- Glamazda, V.V., and V.A. Glazunov, The young fish carry-over into the Ushakovskaya irrigation bypass system on the lower Volga River. *Tr. Volgogr. Otd Geo. Nauchno-Issled Inst. Ozem. Rechn. Rybn. Khoz.*, 10(2):75-86 (in Russian) .  
1976
- Gorodnitchiy, A.E., Characteristics of the biology of young Acipenseridae in the Don River under conditions of regulated run-off. *Zool. Zh.*, 6:1326-37 (in Russian) .  
1955
- Haddingh, R.H., Experimental reduction of fish impingement by artificial illumination at Bergum Power Station. *Int. Rev. Gesamt. Hydrobiol.*, 67(6):887-900.  
1982
- Harden-Jones, F.R., Fish migrations. London, Arnold, 325p.  
1968
- Ivanov, P.V., and S.A. Nebozhenko, Hydraulic and biological investigations of the effects of varying the location of a fish-pass at a weir. Tezisy dokladov II oblastnoy konferentsii molodykh uchenykh. Issledovaniya rybopropusknykh i rybozashchitnykh sooruzheniy. Novocherkassk, NIMI, pp.10-11 (in Russian).  
1984
- Issaev, A.I., and E.I. Karpova, The fisheries of reservoirs. Reference-book. Moscow, Pishchevaya promyshlennost', 304p. (in Russian) .  
1980
- Izvol'skiy, I.S., and A.L. Ersler, On the question of calculating the efficiency of fish-passes. In *Primenenie rybozashchitnykh i rybopropusknykh sooruzheniy*. Moscow (in Russian).  
1978
- Karpova, E.K., and B.S. Malevanchik, On the operation of the hydraulic fish-lift of the Volgogradskiy hydraulic project. *Gidrotekhn. Stroitel'stvo*, (2):8-12 (in Russian).  
1969
- Kashinsev, M.L., E.I. Karpova and Zh.A. Ivanova, Water problems and fisheries. *Rybn. Khoz.*, (063-6 (in Russian).  
1984
- Khamidov, I., The entrapment of young fish by pump stations on the Kairakkumskoye reservoir. In *Zoologicheskiy sbornik. Part 1*. Dushanbe, pp.246-50 (in Russian)  
1975
- Kharchev, G.K., Fish-passing and fish-barring devices. Moscow, Gosstrojizdat, 212p. (in Russian) .  
1940
- Kipper, Z.M., Hydro-engineering and fish-passes. *Rybn. Khoz.*, (6):15-22 (in Russian).  
1959
- Kipper, Z.M., and I.V. Mileiko, Fish-passes in the Soviet Union. *Rybn. Khoz.*, 1962: 73 (in Russian).  
1962

- Kiselev, **O.N.**, The use of echo-sounding in searching for fish. *Rybn. Khoz.*, (in Russian).  
1965
- Kiselev-Tsetskladze**, V.N., Recommendations for the design of fish-protective devices with inclined moving screens. In *Sbornik nauchnykh trudov YuzhNIIGIM. Rybozashchitnye ustroystva na vodozabornykh sooruzheniyakh*. Novocherkassk, pp.90-103 (in Russian).  
1981
- Kobetz, V.N., and V.N. Shkura, On the possible use of model fish in hydraulic-biological investigations.  
1975 *Tr. Novocherk. Inzhen.-Meliorativ. Inst.* 16(b):10-5 (in Russian).
- Kolesnikova, T.V., Characteristics of air-water screens as fish protection devices. In *Vodozabory dlya promyshlennogo stroitel'stva s rybozashchitnymi ustroystvami*. Moscow, pp.35-41.  
1985 (in Russian).
- Koval', **N.V.**, On the ecology of young food fish of the Kremenchugskoye reservoir. *Gidrobiol. Zh.*,  
1978 15(5):44-8 (in Russian) .
- Koval'N.V., I.E. Dyachuk and Ju.A. Volnenko, On fish carry-over into the Desnyanskiy water conduit.  
1979 *Gidrobiol. Zh.*, 15(4):58-62 (in Russian) .
- Kuderskiy**, L.A., On the 'self-settling' of some fish species. *Rybokhozyaistvennoye izuchenie vnutrennikh vodoemov*. Leningrad, GOSNIORKH, N2 (in Russian).  
1970
- Lazarev, **S.I.** and A.A. Schmidt, The results of studies on the determination of the optimum hydraulic conditions in forced action fish-passes. Tezisy **dokladov** II oblastnoy konferentsii molodykh uchenykh, Issledovaniya rybopropusknykh i rybozashchitnykh sooruzheniy. Novocherkassk, Tr. Novocherk. Inzhe. Meliorativ. Inst., pp.15-6 (in Russian).  
1984
- Letichevskiy, MA., Observations on the behaviour of fish in the tailwater of the Kuibyshevskaya dam.  
1957 *Rybn. Khoz.*, (8):65-7 (in Russian).
- Malevanchik, B.S., Artificial spawning grounds at reservoirs of hydroelectric power stations. Moscow,  
1980 **INFORMELECTRO**, 48p. (in Russian).
- Malevanchik, B.S., and I.V. Nikonorov, Fish passing and protecting structures: design problems. Moscow,  
1984 *Legkaya i pishchevaya promyshlennost'*, 256p (in Russian).
- Malikova, E.M., Biochemical changes occurring in vimba spawners during their ascent of the **Kegumskiy** fish-pass. Tr. *Latviisk. Otd. Vses. Nauchno-Issled. Inst. Morsk. Rybn. Khoz.*, Riga. 43:473-77  
1961 (in Russian).
- Marti**, Yu.S., Migrations of marine fish. Moscow, *Pishchevaya promyshlennost'*, 248p. (in Russian).  
1980
- Mel'nikova**, M.B., Protection of young fish at water-intakes. *Rybn. Khoz.*, (4):67-9 (in Russian).  
1984
- Mikheev, P.A., V.M. Slyusarev and V.N. Shkura, Calculation of the attracting flow of fish-passes.  
1982 *Zb. Nauchn. Trudov Gidroproek.*, 80:105-7 (in Russian).
- Moisseev, P.A., and V.G. Dubinina, On the possible ecological consequences of the construction of the  
1987 Volga-Tchogray canal. *Rybn. Khoz.*, (5):19-21 (in Russian).

- Mokryak, G.S., Observations on fish-passage in the Tsimlyanskiy *Nauchno-Tekhn. Byull. Vses.*  
1958 *Nauchno-Issled. Ozem. Rybn. Khoz.*, (6-7):13 (in Russian).
- Muravenko, G.S., The application of experimental planning methods to the study of fish interaction with  
1979 the elements of fish-protection devices. *In Gidrotekhnicheskie sooruzheniya v meliorativnom stroitel'stve.* Moscow, vyp. 12:149-67 (in Russian).
- Mussaenko, B.A., A.V. Podlasov and L.P. Filchagov, The water intakes of irrigational systems and nature  
1982 conservation. Kiev, Budivel'nik Publishers, **116p.** (in Russian).
- Nezdoliy, V.K., Downstream migration of young fishes during the initial period of flow regulation  
1984 of the Ili River. *Vopr. Ikhtiol.*, 24(2):212-24 (in Russian).
- Nikonorov, I.V., The fiftieth anniversary of Glavrybvod. *Rybn. Khoz.*, (4):8-14 (in Russian).  
1984
- Nikonorov, I.V., and M.B. Mel'nikova, On the problems of founding fish-protection at water-intakes on  
1974 technical and biological knowledge. *Rybn. Khoz.*, (2):14-7 (in Russian).
- Nikonorov, I.V., and L.G. Kutyanina, Fish-passes in the USSR. *Rybn. Khoz.*, (7):26-32 (in Russian).  
1976
- Nikonorov, I.V., and B.S. Malevanchik, Engineering-ecological fish-protecting structures. *Rybn. Khoz.*,  
1987 (2):35-9 (in Russian).
- Nikonorov, **S.I.**, M.Yu. Pichugin and L.V. Vitvitskaya, The molecular-genetic foundations of qualitative  
1984 behavioural differences between wild and reared young of Acipenseridae and Salmonidae. *In Mekhanizmi povedeniya. Materiali III Vsesoyuznoy konferentsii po povedeniyu zhivotnykh.* **Vol.1.** Moscow, Nauka, p.9 (in Russian).
- Northcote, T.G., Mechanisms of fish migration in rivers. *In Mechanisms of migration in fishes*, edited by  
1984 J.D. McLeave, et al. *NATO Conf. Ser. 94 Mar. Sci.*, 14:317-65.
- Nussenbaum, L.M., On fish behaviour near dams in relation to the location of fish-passes and fish-  
1961 protecting devices. *Tr.Sov. Ikhtiol. Kom. AN SSSR*, 10 (in Russian).
- ..... Fish behaviour; the breaking of migratory paths. *In Biologicheskoye znachenie i funktsionenaya determinatsiya migratsionnogo povedeniya zhivotnykh.* Leningrad, Nauka.  
1965 (in Russian).
- ..... The scientific basis for using fish-passes and fish-protective devices, and related aspects  
1967 of fish behaviour. *In Povedenie ryb v zone gidrotekhnicheskikh sooruzheniy.* Moscow, Nauka, pp.25-42 (in Russian).
- ..... On experiments using living fish and models of hydraulic projects, in relation to the  
1978 design of fish-passes. *In Biologicheskie osnovy primeneniya rybozashchitnykh i rybopropusknykh sooruzheniy.* Moscow, pp.191-208 (in Russian).
- Nussenbaum, L.M., and L.N. Lapitskaya, The first results of the fish-lift operation at the Volzhskaya  
1961 XXII Congress of the PCUS, Hydroelectric power station. *Rybn. Khoz.*, (1) (in Russian).

- Ozinkovskaya, S.P., T.D. Bondarenko and G.N. Golovko, Observations on the entrapment of fish by the water-intakes of thermal power station No.5. *Rybn Khoz.*, 19: 101-4 (in Russian).
- Pakhorukov, A.M., Trials of air-screen fish protection devices which produce surface flow. *In Povedenie i raspredelenie molodi ryb.* Moscow, IEMEZh AN SSSR, pp.122-36 (in Russian).
- Pakhorukov, A.M., A.N. Chernousov and S.D. Dzhakupov, The ecological protection of young fish at the Gur'evskiy water-intake on the Ural River. *In Vodozabory dlya promyshlennogo stroitel'stva s rybozashchitnymi ustroystvami.* Moscow, pp.26-34 (in Russian).
- Pakhorukov, A.M., and G.N. Kuragina, Biological investigation of some fish-protecting devices which incorporate fish-diverters. *In Biologicheskie osnovy primeneniya rybozashchitnykh i rybopropusknykh sooruzheniy.* Moscow, pp.98-112 (in Russian).
- Pavlov, D.S., For fish protection. *Rybovod. Rybolov.*, (4) (in Russian).  
1966
- ..... The optomotor reaction and peculiarities of fish orientation in a water flow. Moscow, 1970 Nauka, 148p. (in Russian).
- ..... The biological bases of fish behaviour control in a water flow. Moscow, Nauka, 319p. (in Russian).  
1979
- ..... Migration of fish in inland water bodies and their relation to flow. *Zh. Obsh. Biol.*, 1986 11(2):179-81 (in Russian).
- Pavlov, D.S., and V.N. Kobets, Bio-hydraulic studies on young fish. *Trudy NIMI*, Vol. 11 (in Russian).  
1974
- Pavlov, D.S., and A.M. Pakhorukov, The biological bases of preventing fish from entering water-intake devices. Moscow, Pishchevaya Promyshlennost', 208p. (in Russian).
- ..... The biological bases of preventing fish from entering water-intake devices. Moscow, 1983 Legkaya i Pishchevaya Promyshlennost', 264p. (in Russian).
- Pavlov, D.S., and E.N. Saburenkov, The speeds and peculiarities of fish movement. *In Osnovnye osobennosti povedeniya i orientatsii ryb.* Moscow, pp.155-86 (in Russian).  
1974
- Pavlov, D.S., E.A. Shepvalov and I.I. Ripinskiy, The influence of dark adaptation on the distribution of young minnows in rheogradients subject to artificial illumination. *In Raspredelenie i migratsii molodi ryb vo vnutrennikh vodoemakh.* Moscow, IEMEZh AN SSSR, pp.141-51 (in Russian).  
1986
- Pavlov, D.S., and L.G. Shtaf, The distribution of young drifting fish in a rheogradient. *Dokl Akad. Nauk SSSR*, 260 (2):509-12 (in Russian).  
1981
- Pavlov, D.S., MA. Skorobogatov and L.G. Shtaf, The threshold velocities of rheoreaction in roach in water flows with differing degrees of turbulence. *Dokl Akad. Nauk SSSR*, 268 (2):510-2 (in Russian).  
1982

- ..... The influence of turbulent flow on the critical current velocity of fish. *Dokl Akad. Nauk SSSR*, 267(4):1019-21 (in Russian).  
1982a
- Pavlov, D.S., and S.N. Tyuryukov, The hydrodynamic mechanism of orientation in fish in flowing water. 1986 *Rybovodstvo*, (2):32-9 (in Russian).
- Pavlov, D.S., and B.Ya. **Vilenkin**, The present state of the environment, biota and fisheries of the Volga in press River. *In Proc. Intemtl. Large River Symp.*, Canada.
- Pavlov, D.S. *et al.*, The downstream migration of young fish in the Volga and Ili Rivers. Moscow, Nauka, 1981 **320p.** (in Russian).
- ..... Ecological fish-protection at outflows. Moscow, Nauka, **112p.** (in Russian) .  
1982
- ..... The characteristics of hydraulic flows which create fish movement paths. *Dokl Akad. Nauk SSSR*, 270(6):1513-6 (in Russian).  
1983
- ..... Downstream fish migration from the Ivan'kovskoye reservoir. *In Povedenie i raspredelenie molodi ryb.* Moscow, IEMEZh AN SSSR, pp.4-46 (in Russian).  
1984
- ..... The swimming duration of some fish at different speeds. *Dokl Akad Nauk SSSR*, 278(5):1277-80 (in Russian).  
1984
- ..... Downstream fish migration from water-bodies with reduced water exchange. Moscow, IEMEZh AN SSSR, **137p.** (in Russian).  
1985
- Petrashkevich, V.V., Analysis of the operation of fish protection devices incorporating filters. *Gidrotekhn. Stroitel'stvo*, (6):28-33 (in Russian).  
1986
- Poddubniy, A.G., The ecology of fish populations in reservoirs. Leningrad, Nauka, 309p. (in Russian) .  
1971
- Poddubniy, A.G., L.K. Malinin and Yu.S. Spektor, Biotelemetry in fish breeding science and practice. 1979 Moscow, Pishchevaya promyshlennost', **191p.** (in Russian).
- Poddubniy, A.G. *et al.*, Peculiarities of the passage of spawners through typical river sites, dam tailwaters and reservoirs. *In Biologicheskie osnovy primemeniya rybozashchitnykh i rybopropusknykh sooruzheniy.* Moscow, pp.209-17 (in Russian).  
1978
- Protasov, V.R., and A.G. Gusar, On the influence of navigated pathways on the distribution of some fish species. *Dokl Akad. Nauk SSSR*, 262(1):255-6 (in Russian).  
1982
- Sakun, **O.F.**, The analysis of genital gland condition in vimba specimens passing through the Kegumskiy fishway. *Uch. Zap. Leningr. Gos. Univ. (Ser. Biol. Nauk)*, 44(228) (in Russian).  
1957
- Schiemenz, T., Ersatz des Instinktmassigen Wanderns der Fische in Fischtreppen durch das reflektorische Wandern als Grundlage **zum** Bau von Fischtreppen, sowie Orientierung und das Verhalten der Fische in Fischtreppen. *Z. Fischerei*, 6(1-7):64-84.  
1957

- Shimanovskaya, L.N., *et al.*, The fishery use of USSR lakes, rivers and reservoirs. *In Rybnoe khozyaistvo vnutrennikh vodoemov i perspektivy ego razvitiya. Zb. Nauchn. Dud., Leningrad,* 1983 193:3-92 (in Russian).
- Shkura, V.N., Fish-passes of projects with low hydraulic head. Novocherkassk, 1979, 100p. (in Russian) .
- ..... Fish-passes of projects with low and medium hydraulic heads. *Gidrotekhn. Melioratsiya,* 1986 (9):9-13 (in Russian).
- Shmidt, P.Yu, Fish migrations. Moscow & Leningrad, Gosizdat biologicheskoy i meditsinskoy literatury, 1936 326p. (in Russian).
- Skorobogatov, MA., *et al.*, How to chose fish-pass location. *Dokl. Akad Nauk SSSR,* 272(1):250-3 1983 (in Russian).
- Strakhov, V.A., The electric fish barrier ERZU-1, choice and calculation of parameters. *Tr. Koordin. Sov. Gidrotekhn.,* 24:67-8- (in Russian). 1965
- Strakhov, V.A., and L.M. Nussenbaum, The testing and adoption of electrical barriers for fish. 1959 *Rybn. Khoz.,* (5):35-42 (in Russian).
- Sukalo, G.M., and V.N. Shkura, On the use of the bottom bulkhead as a fish guiding device. *Zb. Nauchn. Tr. Vses. Proekt. Nauchno-Issled. Inst. Gidroproekt.,* (80):70-2 (in Russian). 1982
- Tikhiy, M.V., and P.V. Viktorov, Fish stocks and hydro-construction. Moscow, Pishchepromizdat, 200p. 1940 (in Russian).
- Trefethen, P., Fish-passage research: review of progress. *Circ. U.S. Fish. Wildl. Serv.,* (254):23p. 1968
- Trusov, V.Z., The behaviour of sturgeon and stellate sturgeon in the tailwater of the dam of the Volzhskaya XXII Congress of PCUS hydroelectric power station. *Tr. Tsent. Nauchno-Issled. Inst. Osetrov. Khoz.,* 2:167-79 (in Russian). 1970
- Tsyplyaev, A.S., Screen fish-protective devices with diverter. Moscow, Pishchevaya promyshlennost', 1973, 160p. (in Russian).
- Umanets, U.K., and A.A. Bykov, The optimization of fish-passage under conditions of irregular water distribution at a weir. Tezisy dokladov oblastnoy konferentsii molodykh uchenykh Issledovaniya rybopropusknykh i rybozashchitnykh sooruzheniy. Novocherkassk, pp.41-3 (in Russian). 1982
- Vatshinnikov, A.E., Behaviour and distribution of young fish adjacent to river-bed water-intakes. *In Raspredelenie i migratsii ryb vo vnutrennikh vodoemakh.* Moscow, IEMEZH AN SSSR, pp.91-105 (in Russian). 1986
- Verzin, Yu.N., and Glamazda V.V., The dynamics of the entrapment of young fish from the Tsymlyanskoye reservoir by water-intakes of the Generalovskaya irrigation system. *In Biologicheskiye osnovy ispol'zovaniya rybozashchitnykh i rybopropusknykh sooruzheniy.* Moscow, Nauka, pp.89-93 (in Russian). 1978



- Vibert, R., General report of the Working Party on the applications of electricity to inland fishery biology and management. In Fishing with electricity; its application to biology and management. Contributions to a Symposium, edited by R. Vibert. London, Fishing News Books, pp. 3-51. 1967
- Weaver, C.R., Influence of water velocity upon orientation and performance of adult migrating salmonids. Fish. Bull. U.S. Fish. *Wildl.* Ser v., 63(1):97-121. 1962
- Zhidovinov, V.I., The influence of water-intakes and water-discharge pipes on the entrapment of young fish by pumping stations. In Zbornik Okhrana i vosproizvodstvo rybnikh zapasov basseina Kaspiyskogo morya. Moscow, ONTI VNIRO, pp.82-9 (in Russian). 1986
- Zhuykov, A.Yu., The peculiarities of conditioned reaction in young Atlantic salmon in reproduction. 1986 Thesis of diss. cand. biol. sci., Moscow, IEMEZh AN SSSR (in Russian).

## GLOSSARY OF SYMBOLS AND NOTATIONS

$H_f$  The mid-section area of a fish's body.

The intensity of turbulence ( $= d/V$ , where  $d$  = standard deviation of pulse velocity and  $V$  = velocity).

$K_d$  The velocity ratio in a fish diverting device, relative to  $V_{appr} = V_d/V_{appr}$ .

$K_{dw}$  The velocity ratio in a fish diverting device ( $= V_{div}/V_m$ ).

$K_{irr}$  Coefficient of irregularity (defines the velocity distribution across a section of fish collector).

$K_{net}$  The velocity ratio in the meshes of a net screen ( $=$

$K_r$  Redistribution coefficient ( $= C_1/C_2$ , where  $C_1$  = fish concentration in fish divertor and  $C_2$  = fish concentration in main intake).

Clear space size or area in permeable barriers.

$N$  The quantitative index of barrier permeability to fish.

The coefficient of net perforation.

$R_{av}$  The avoidance reaction of a fish.

$R_b$  The strength of the fish's overall response to the stimulus received from the barrier.

$R_{rh}$  The fish's reaction to a current (i.e. rheoreaction).

$R_s$  The strength of the search reaction.

$T_{dr}$  The duration of a fish's drift along a barrier.

Swimming performance of fishes. The duration of active swimming as a function of a fish's speed.

$V_s$  The absolute swimming speed of a fish.

$V_{appr}$  The velocity of the approach flow.

$V_{attr}$  The attracting flow velocity.

$V_{av}$  The average flow velocity.

$V_c$  Critical current velocity. The minimum current velocity at which fish begin to be carried away by the water flow.

$V_c$  A fish's cruising speed

$V_{dis}$  The velocity of displacement or transit of a fish.

$V_{div}$  The velocity of the fish-diverting flow.

The velocity of the flow.

$V_{fv}$  The average filtration velocity in filter intakes.

$V_m$  The velocity of flow through the meshes of a net.

$V_{cr}$  The critical speed of model fish.

- $V^m_i$  The flow velocity in a model.
- $V^c_{cr}$  The critical speed of spawners in nature.
- $V^n_i$  The flow velocity in natural conditions.
- $V_{norm}$  The relative current velocity normal to the barrier ( $= VO$ ).  
The optimum attracting flow velocity.
- $V_i$  The fish's speed relative to fixed cues.
- $V_{res}$  The resistance velocity of a fish.
- $V_{sel}$  The current velocity selected by a fish.
- $V_{th}$  Threshold current velocity. The minimum current velocity which provokes an orientation reaction against the current.
- $V_{tr}$  The velocity of the transit or fish diverting flow (which diverts fish in the absence of a fish-diverting device).
- The angle of the barrier relative to the axis of water flow

## APPENDIX 1

### LIST OF SPECIES CITED IN TEXT

<i>Abramis ballerus</i>	blue bream
<i>Abram is brama</i>	common bream
<i>Acerina cernua</i>	ruff
<i>Acipenser güldenstädti</i>	Russian sturgeon
<i>Acipenser nudiventris</i>	bastard sturgeon
<i>Acipenser stellatus</i>	stellate sturgeon
<i>Acipenser ruthenus</i>	sterlet
<i>Alburnus alburnus</i>	bleak
<i>Anguilla anguilla</i>	common eel
<i>Aspius aspius</i>	asp
<i>Barbus brachycephalus</i>	Aral barbel
<i>Blicca bjoerkna</i>	silver bream
<i>Carassius carassius</i>	Crucian carp
<i>Chakalburnus chakoides</i>	shemaya
<i>Clupea harengus</i>	herring
<i>Clupeonella delicatula</i>	tyulka
<i>Cobitis taenia</i>	spined loach
<i>Coregonus lavaretus baeri</i>	whitefish
<i>Cottus gobio</i>	bullhead
<i>Cyprinus carpio</i>	common carp
<i>Esox lucius</i>	pike
<i>Huso huso</i>	giant sturgeon
<i>Leuciscus idus</i>	orfe or ide
<i>Nemacheilus barbatulus</i>	stone loach
<i>Onchorhynchus gorbuscha</i>	pink salmon
<i>Osmerus eperlanus eperlanus</i>	European smelt
<i>Pelecus cultratus</i>	sabrefish
<i>Perca fluviatilis</i>	perch
<i>Rhodeus sericeus</i>	bitterling
<i>Rutilus rutilus</i>	roach
<i>Rutilus rutilus caspius</i>	vobla
<i>Salmo gairdneri</i>	rainbow trout
<i>Salmo salar</i>	Atlantic salmon
<i>Salmo trutta aralensis</i>	Aral trout
<i>Scardinius erythrophthalmus</i>	rudd
<i>Silurus glanis</i>	sheatfish
<i>Stenodus leucichthys leucichthys</i>	Caspian inconnu
<i>Stizostedion lucioperca</i>	pike-perch or zander
<i>Stizostedion volgensis</i>	Volga zander
<i>Tinca tinca</i>	tench
<i>Kmba vimba</i>	vimba

## **APPENDIX 2**

### **PLATES**

1. Fish retention grid of the Krasnodarskiy fish-lift on the Kuban' River.
2. Fish-pass sluice of the Kochetovskiy hydraulic scheme on the Don River.
3. Fish protection screens with movable screen elements.
4. Drum screen with blade.
5. Placing the drum screen with blade at the water-intake head.
6. Fish-protection intake with a flow-former.
7. A horizontal panel screen with a fish diverting device
8. Vertical panel V-screens with a fish-diverting device in each section.
9. Conical fish-barriers with fish-diverting devices.

Photographs 3,7,8 & 9 by A.O.Kuchis.



Plate 1. Fish retention grid of the Krasnodarskiy fish-lift on the Kuban' River.



Plate 2. Fish-pass sluice of the Kochetovskiy hydraulic scheme on the Don River.



Plate 3. Fish protection screens with movable screen elements.



Plate 4. Drum screen with blade.



Plate 5. Placing the drum screen with blade at the water-intake head.





Plate 6. Fish-protection intake with a flow-former



Plate 7. A horizontal panel screen with a fish diverting device



Plate 8. Vertical panel V-screens with a fish-diverting device in each section.



Plate 9. Conical fish-barriers with fish-diverting devices.





