

FIRST SIDE PLANK

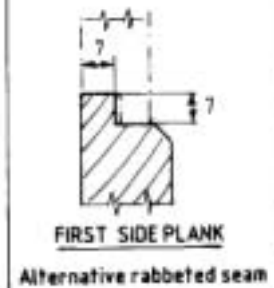

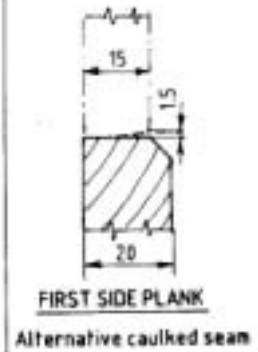

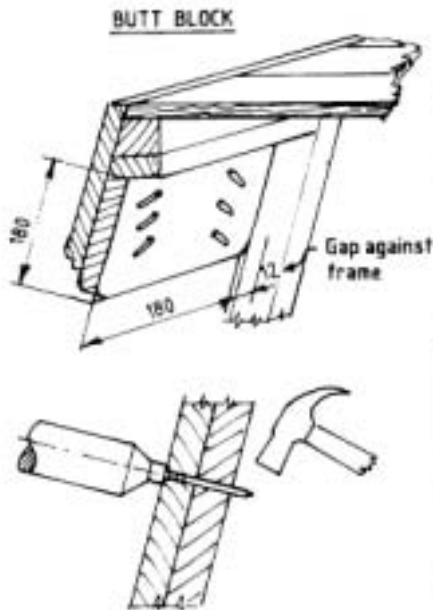

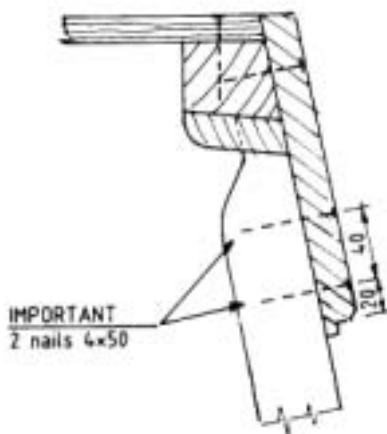
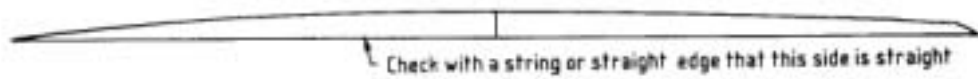
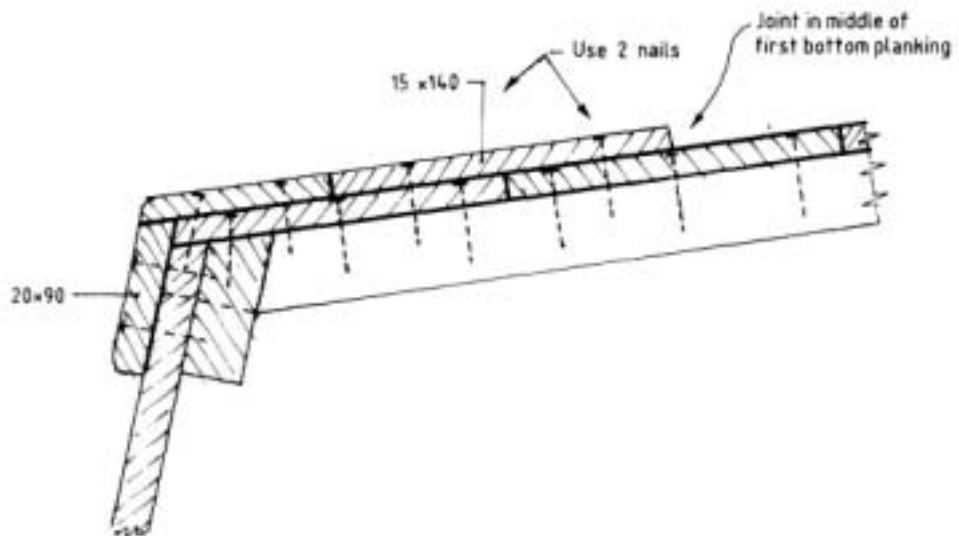
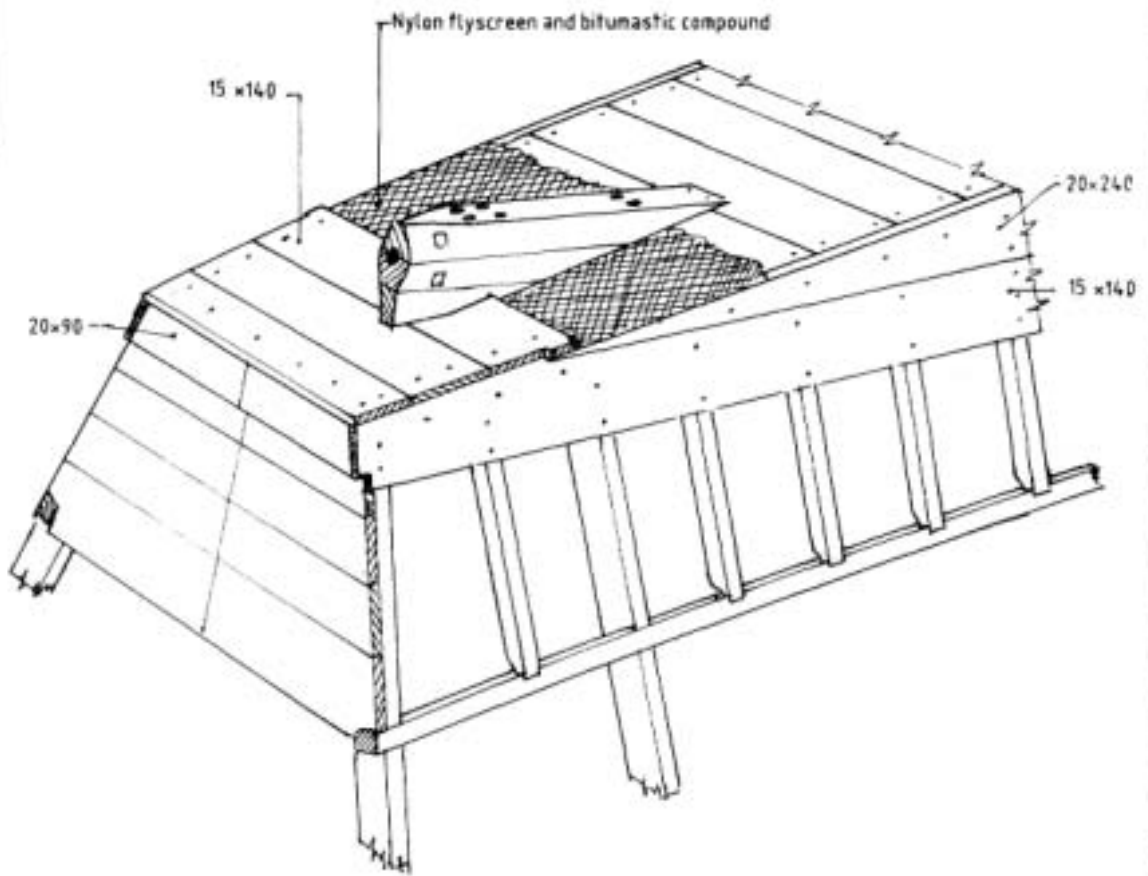
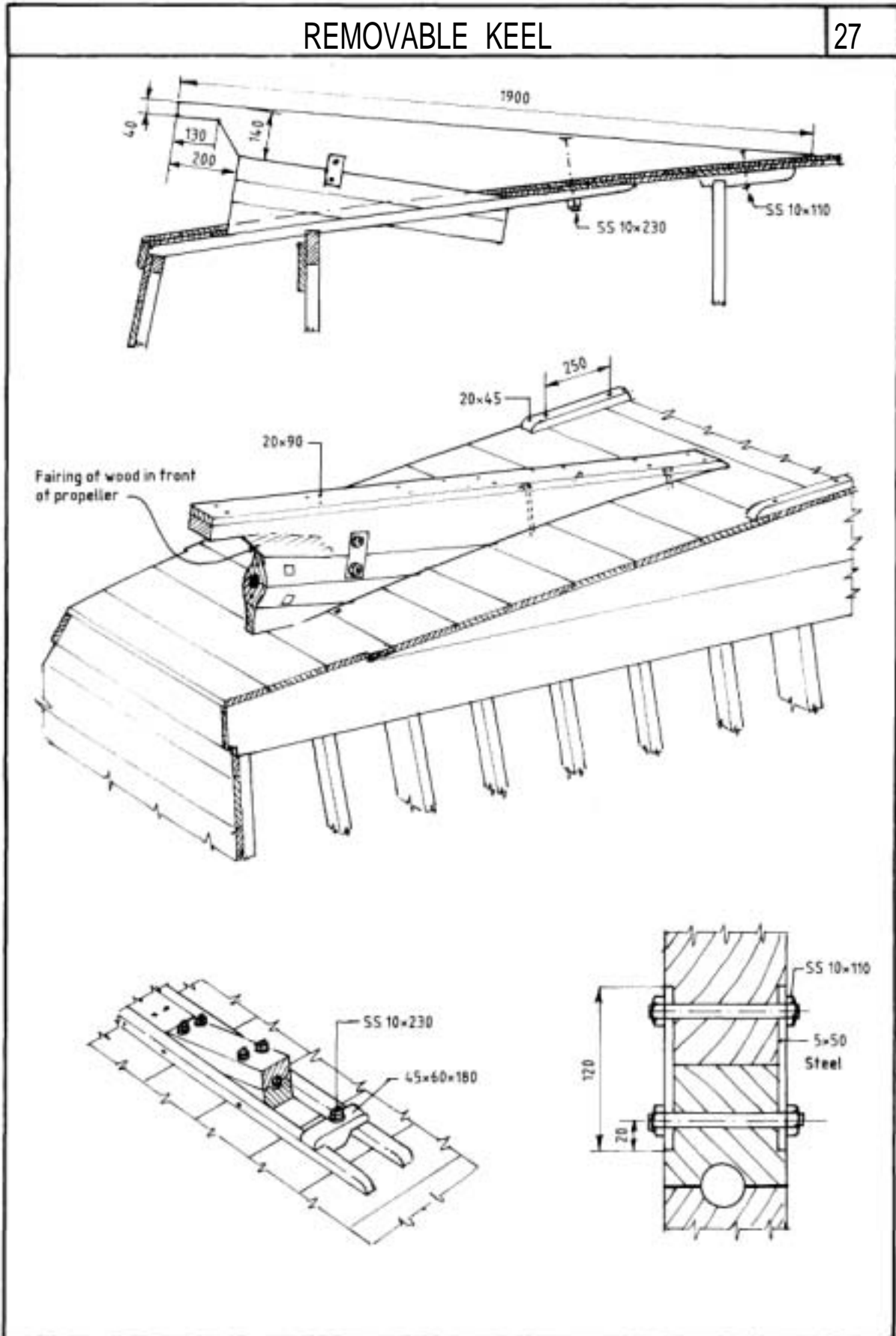
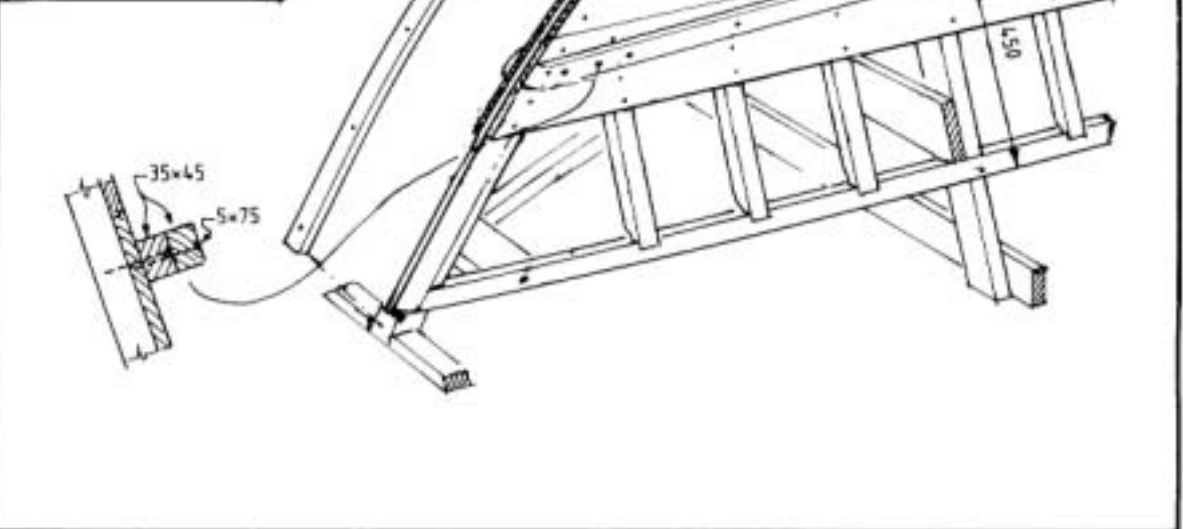
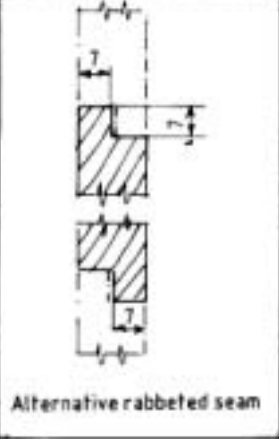
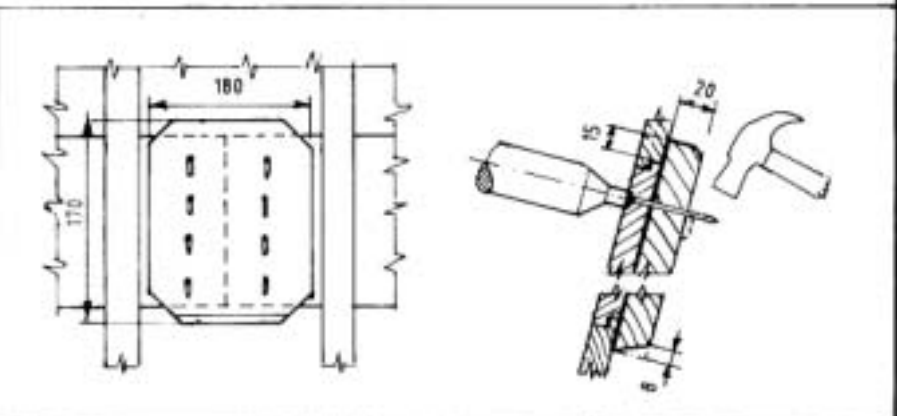
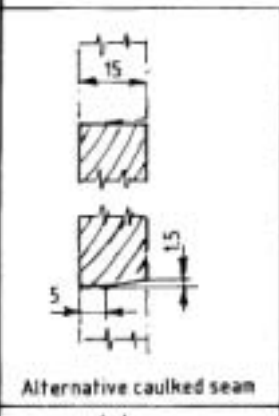
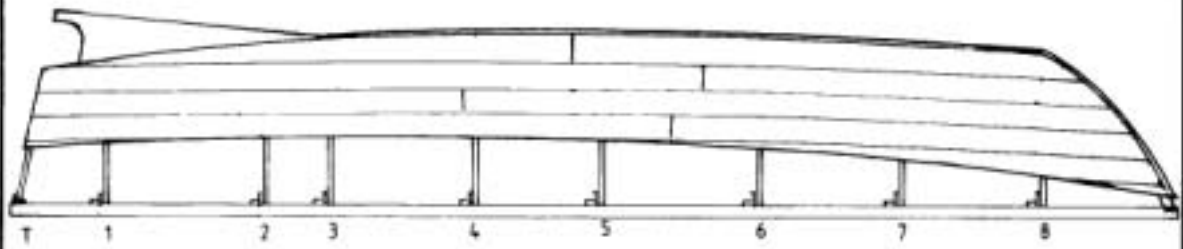

ALTERNATIVE : RABBETED JOINT WITH BITUMASTIC COMPOUND

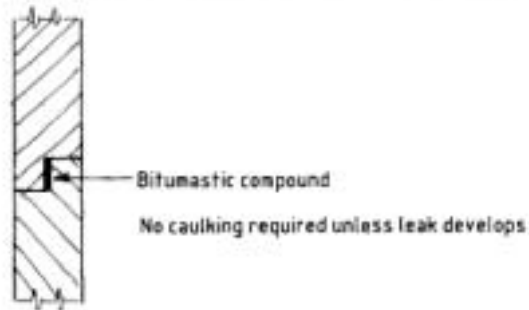

ALTERNATIVE : CAULKED JOINT

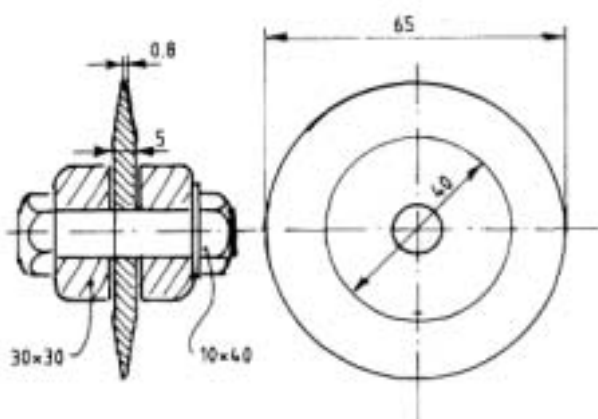
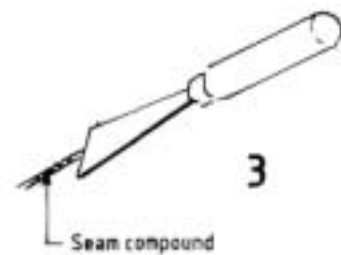
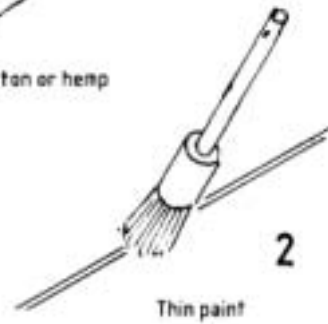
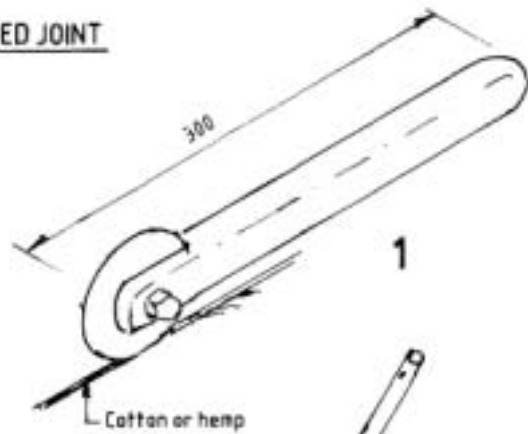
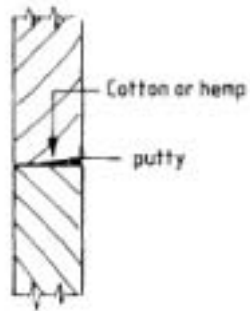

CAULKING WHEEL

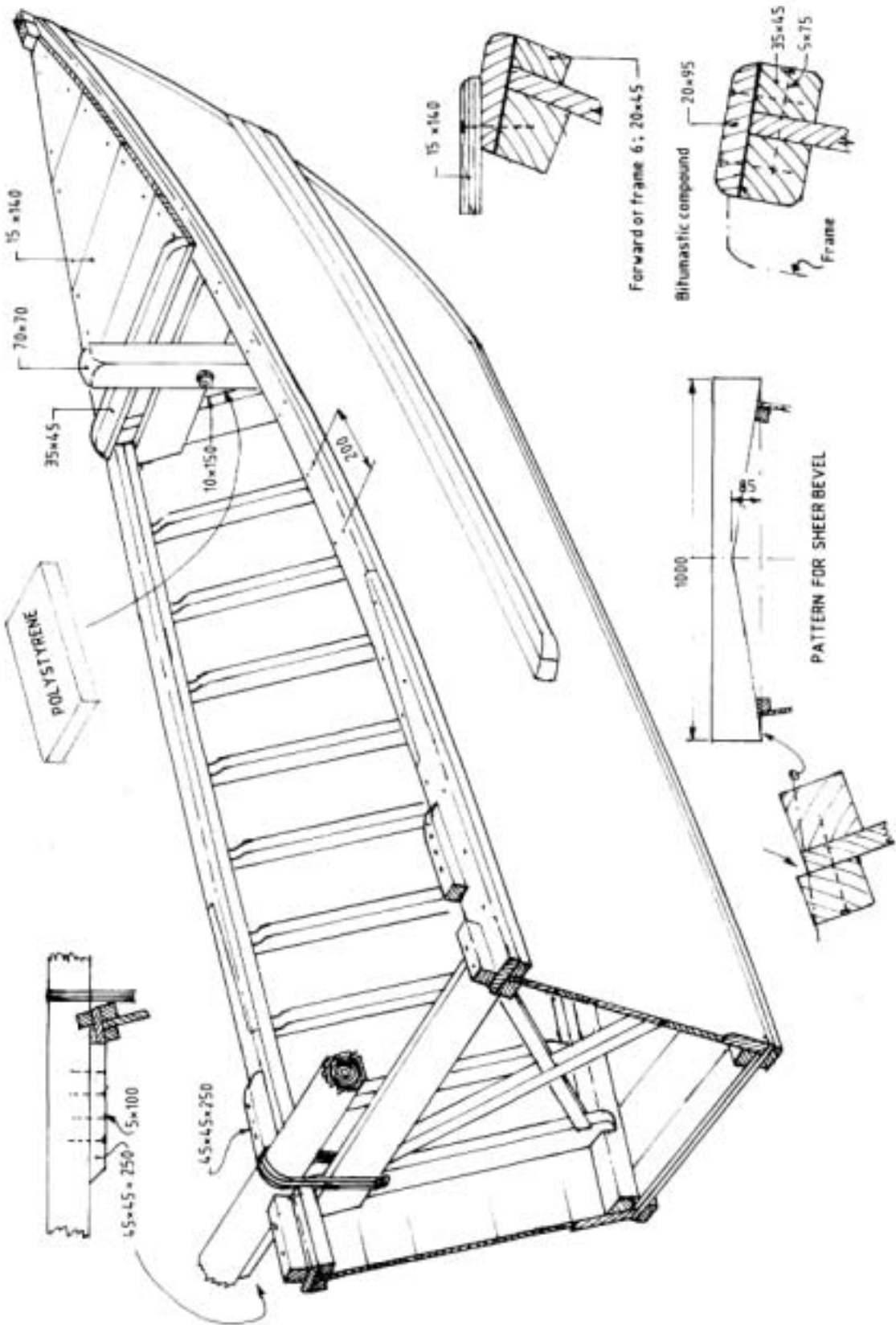

# ENGINE BED

31

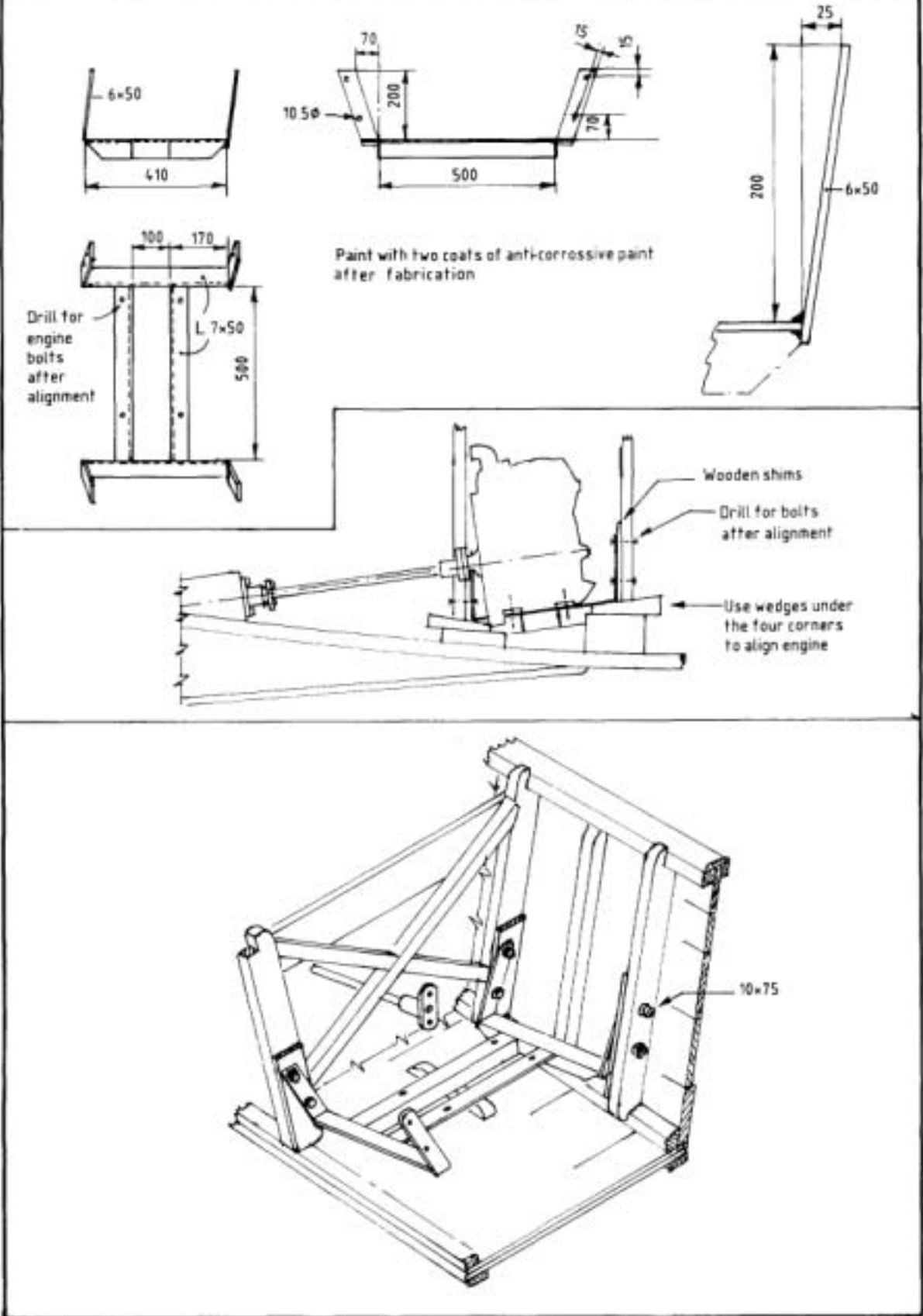

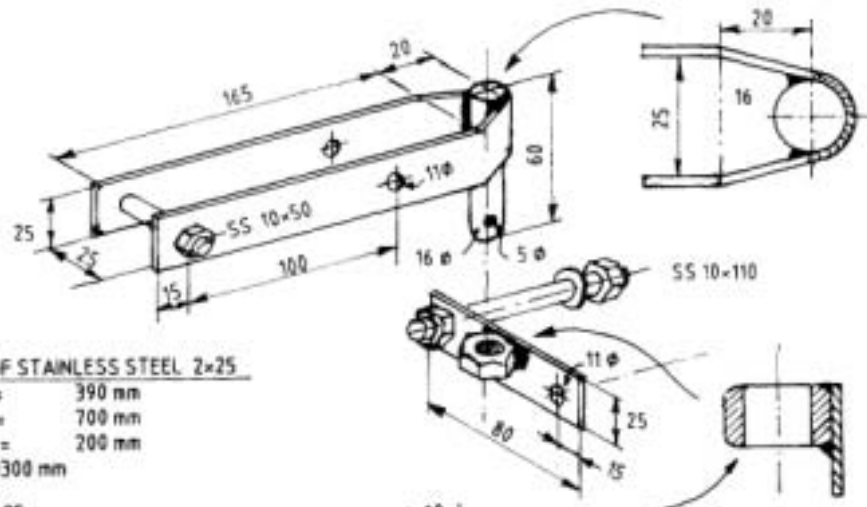

**RUDDER FITTINGS MADE OF STAINLESS STEEL 2x25**

Upper fork total length = 390 mm  
 Lower fork total length = 700 mm  
 Two plates total length = 200 mm  
 TOTAL LENGTH 2x25 = 1300 mm

**ALTERNATIVE: STEEL 5x25**

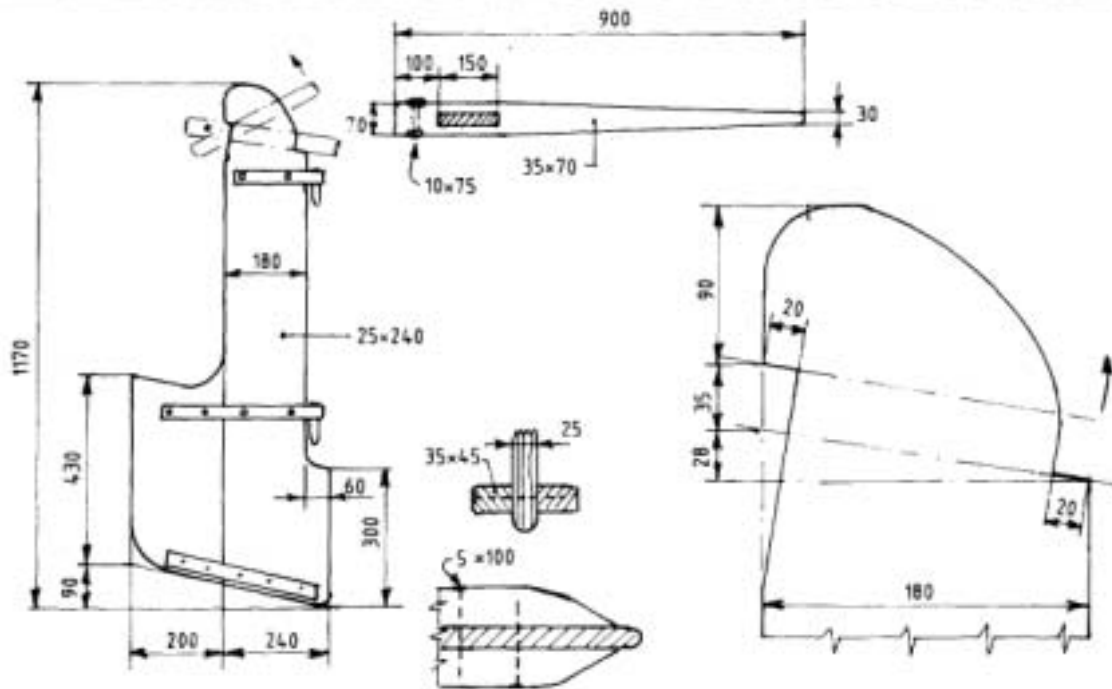
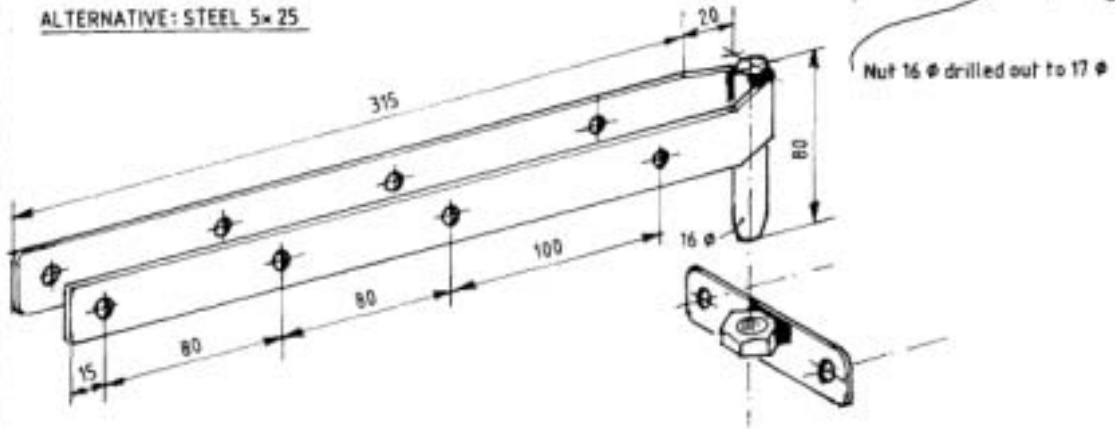



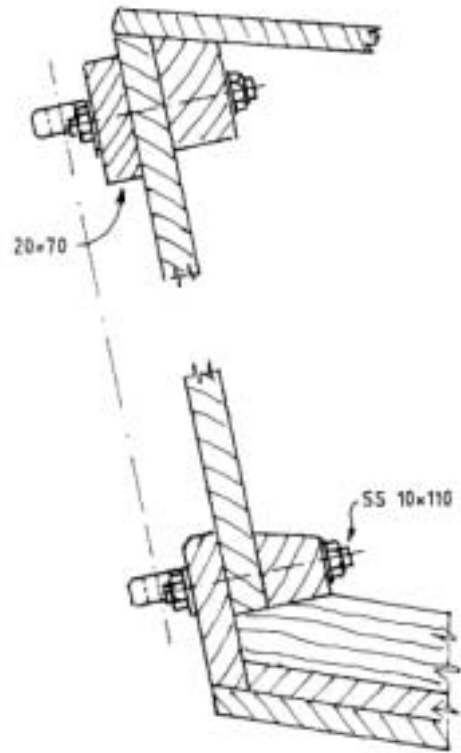
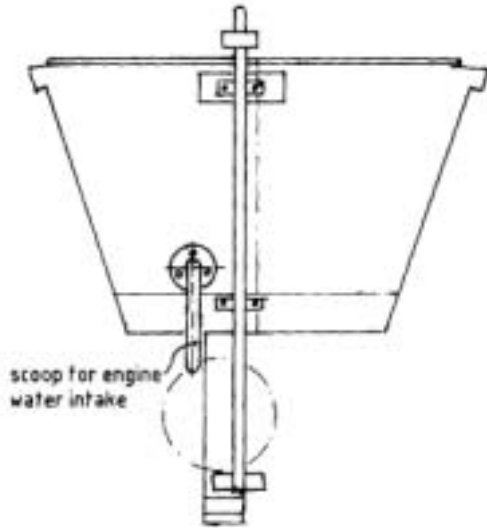

Fill up void spaces under aft deck and foredeck with polystyrene

