



TCP/MDV/4452
Field Document 1

**INCEPTION REPORT ON
SEA CUCUMBER CULTURE IN LAAMU ATOLL**

MALDIVES

based on the work of

Dr. D.B. James

FAO Consultant

FOOD AND AGRICULTURE ORGANIZATION OF THE UNITED NATIONS

Bangkok, 1996



TCP/MDV/4452
Field Document 1

**INCEPTION REPORT ON
SEA CUCUMBER CULTURE IN LAAMU ATOLL**

MALDIVES

based on the work of

Dr. D.B. James

FAO Consultant

FOOD AND AGRICULTURE ORGANIZATION OF THE UNITED NATIONS

Bangkok, 1996

The designations employed and the presentation of the material in this document do not imply the expression of any opinion whatsoever on the part of the Food and Agriculture Organization of the United Nations concerning the legal status of any country, territory, city or area or of its authorities, or concerning the delimitation of its frontiers or boundaries.

The Food and Agriculture Organization is greatly indebted to the organizations and individuals who assisted in the implementation of the project by providing information, advice and facilities.

TABLE OF CONTENTS

	<u>Page</u>
1. INTRODUCTION	1
2. FINDINGS AND RECOMMENDATIONS	
2.1 Spawning, Larval Rearing and Production of Seedstock for Commercial Tropical Sea Cucumbers	2
2.2 Culturing Techniques of Commercial Tropical Sea Cucumbers	3
2.3 Procurement and Culture of Food Organisms for Larval Stages of Commercial Tropical Sea Cucumbers	3
2.4 Procurement of Pertinent Literature on the Culture, Biology and Ecology of Commercial Tropical Sea Cucumber	3
3. GENERAL LAYOUT FOR THE HATCHERY	4
4. CULTURE	5
4.1 Isolation of <i>Phytoflagellates</i>	5
4.2 Stock Culture	5
4.3 Mass Culture	6
4.4 Mixed Algal Culture	6
5. PLAN OF WORK AND EQUIPMENT	6
FIGURE 1 - 10 Plan for Hatchery and Related Specifications	8
ANNEX 1 Budget Details and Summary	14
ANNEX 2 List of Additional Equipment Required	18
APPENDIX 1 Publications on Taxonomy, Anatomy, Biology, Ecology, Hatchery and Culture of Commercial Tropical Sea Cucumbers	21

1. INTRODUCTION

Within the scale of the TCP Project "Laamu Atoll Mariculture", the consultant was recruited on a when-actually-employed basis with the following terms of reference:

- Make an initial visit to the mariculture site in Laamu Atoll, to provide written recommendations on spawning, larval rearing and production of seedstock for commercial tropical sea cucumbers.
- Provide subsequent technical backstopping via telephone, facsimile and/or electronic mail consultations, with regard to culturing techniques of commercial tropical sea cucumbers.
- Provide assistance in procurement and culture of food organisms for larval stages of commercial tropical sea cucumbers.
- Provide assistance in the procurement of pertinent literature on the culture, biology and ecology of commercial tropical sea cucumbers.
- Make a follow-up on site visit, to troubleshoot problems, and monitor progress and a final visit to complete the project in good order and draft the Terminal Statement.

The consultant reached the Maldives on 12/12/95 and stayed in Male upto 15/12/95. During his stay in Male, he met the Director General of Fisheries the Ministry of Fisheries and Agriculture, the Director of Fisheries and the Fisheries Resources Officer of the Ministry of Fisheries responsible for the sea cucumber project in Laamu Atoll. The Director, Oceanographic Society of Maldives (OSM) furnished further background information for the project. On 15/12/95, the consultant left for Kadhdhoo Island situated on the Laamu Atoll. The project site is on Gamu Island and it is 12 km. from the Kadhdhoo Island. The consultant visited the site daily and had detailed discussion with an American scientist stationed at Gamu Island and working on seaweeds. The FAO Representative for Sri Lanka and Maldives paid a visit to the project site and briefed the consultant on the plan of work to be conducted. He also furnished details on the budget for the project.

The Oceanographic Society of Maldives, a Non-Government Organisation (NGO) in the Maldives, have constructed a building with the help of the Canadian Government in Gamu Island on Laamu Atoll. The building consists of two rooms and is situated about 150 m from the sea. They have also constructed two small rooms for a generator and the other to be used as store room. The Oceanographic Society of Maldives is contributing the services of one American Scientist to work on sea cucumbers. He is at present working on the asexual reproduction of some of the commercially important sea cucumbers and also making studies on the movements and feed requirements of sea cucumbers by constructing pens in shallow waters. Once the sea cucumber hatchery becomes fully operational, time should be devoted to the production of sea cucumber seed.

2. FINDINGS AND RECOMMENDATIONS

2.1 Spawning, Larval Rearing and Production of Seedstock for Commercial Tropical Sea Cucumbers

- Seed production of *Holothuria fuscogilva* and *Thelenota ananas* which are found to be distributed in 30 to 40 m. depth can be taken up in the first instance. These two species of sea cucumbers have good economic value.

- The breeding season for the above two species is from December to March in the Maldives. Therefore, the seed production experiments can be taken up during this period.
- The two rooms constructed at Gamu Island by the Oceanographic Society of Maldives can be converted into a mini sea cucumber hatchery with suitable modifications.
- Always brood stock has to be maintained in the hatchery in brood stock tanks in healthy condition for thermal stimulation whenever required.
- The larger room constructed by the project can be used as a wet laboratory for larval rearing. A small portion of this laboratory is set apart for the examination of larvae, preparation of algal extract etc.
- The smaller room can be partitioned and the toilet should be shifted outside. This would allow space for stock culture and for mass culture. The temperature in this room should be maintained at 20-22°C for the optimum growth of micro-algae.
- The basic plan for the hatchery is given in Fig. 1. The sea water can be drawn directly from the sea by PVC pipe (90 mm. diameter) by gravitation to a well sunk near the shore.
- At Gamu Island, fresh water is available at a depth of 1 m. Therefore before sinking the well near the shore, the salinity of the sub-soil water has to be tested. During the high tide, sea water flows into the well by gravitation.
- If the water in the well becomes less saline due to fresh water influx, then the sea water can be directly pumped to the sedimentation tank. For the development of the sea cucumber larvae, the salinity of the sea water used should be around 33 to 35 ppt.
- The filter bed is used as a biological filter. Inside the filter bed at the bottom gravel in the middle coal and at the top river, sand is provided to a thickness of 30 to 45 cm. The river sand has to be changed once in 15 days and the filter bed has to be cleaned with bleaching powder once in three months.
- Despite the biological filter and the UV filter if bacteria are found in the sea water leading to heavy mortality of the larvae, then de-chlorinated sea water has to be used. Chlorination up to 6 ppm. will kill all the pathogens.
- A proper drainage has to be arranged in the hatchery to remove the waste water. The water so removed should be let out at the other end.
- A separate store room may be constructed to keep all the diving and other equipment of the laboratory.
- All the pipes used in the hatchery should be made of PVC material and no metal pipes should be used to avoid corrosion,
- The two small rooms already constructed a little away from the main building can be used as compressor room and generator room.

2.2 Culturing Techniques of Commercial Tropical Sea Cucumbers

The Consultant is in touch with the Director of Oceanographic Society, the Director of Fisheries and other officials of Maldives regarding the seed production of sea

cucumbers to provide any required advice on culture techniques of commercial tropical sea cucumbers.

2.3 Procurement and Culture of Food Organisms for Larval Stages of Commercial Tropical Sea Cucumbers

The Consultant has already provided a sample of *Isochrysis galbana* which is the chief feed used for rearing sea cucumber larvae. The larvae of sea cucumbers are known to feed well on this microalgal. The growth is good and also the mortality rate is low when fed on this food. This culture is now maintained in a refrigerator at the Marine Research Section in Male. The isolation method for the micro-algae and the Conway or Walne's medium used in the stock culture are also given in Section 4.

2.4 Procurement of Pertinent Literature on the Culture, Biology and Ecology of Commercial Tropical Sea Cucumber

The Consultant has already supplied twenty-one publications on taxonomy, anatomy, biology, ecology, hatchery and culture of commercial tropical sea cucumbers (Appendix I). He will continue to publish papers.

Subject to the clearance by the Government of India, the consultant will be available for further missions as provided for in the work plan.

3 GENERAL LAYOUT FOR THE HATCHERY

A brief description of the layout of the hatchery is given here. As stated earlier, the sea water is drawn into a well by gravitation. If the salinity of the sub-soil water is low, the sea water is directly drawn into a sedimentation tank (3.5 x 2.5 x 1 m.) by using 1 hp motor. The sea water is allowed to settle down. The water in the storage tank overflows and goes to a filter bed (2 x 1 x 1 m.). This filtered sea water is then let to storage pump (4 x 4 x 1.5 m.). From the pump, this water is taken to an overhead tank by using 7 hp. motor. The overhead tank should be higher to give sufficient pressure for the circulation of sea water in the hatchery. Sea water from the overhead tank on entering the hatchery passes through UV filter. This water is drawn through pipes at various points. In the wet laboratory four one-ton tanks (Fig. 2) are kept on cement blocks (Fig. 6). The cement blocks are arranged in 2 tiers to give sufficient height for siphoning out the water. Under each tank, 12 cement blocks are arranged and over the cement blocks a wooden frame (Fig. 5) is placed. The one-ton tank is kept over this wooden frame to distribute the weight of the tank uniformly. If the wooden frame is not used, the tank will develop cracks due to unequal distribution of weight. Two one-ton tanks are kept outside to maintain the broodstock. When the broodstock and larvae are present in one ton tank, the water is changed daily by siphoning it out. The tanks are covered with black cloth. The water in the wet laboratory is let out into the drainage. The drainage water should not come in contact with the intake water. In the wet laboratory, there is a platform on which a microscope, larval counting chamber, mixie and other equipment can be kept.

The second room is set apart for the micro-algal culture. One fourth of the room is partitioned and used for the stock culture and in this room, one air-conditioner is installed. Four racks (Fig. 7) can be installed in this room. In each shelf of the rack, seven Haufkin's culture flasks (Fig. 8) of 4 litres capacity can be placed. These flasks are arranged in the upper and middle shelves of the racks. Out of four, only in three racks Haufkin's flasks are arranged. In the fourth rack, cultures can be maintained in the test tubes sand conical flasks of different capacities. In each shelf of the rack, four tube lights (40 watts) are installed as shown in the figure. It is better to keep all the chokes of the

tubelight outside the stock culture room to avoid excess of heat. All the tube lights should be connected to a timer switch to provide 12 hours light (0600-1800 hrs.). Six racks (Fig. 9) can be installed in the mass culture room. In one rack, four perspex tanks (Fig. 10) can be arranged with two in each shelf. In one shelf at the bottom, three glass carboys (Fig. 11) of 20 litre capacity are arranged. Four tube lights for each shelf have to be arranged. Here also the light may be provided for 12 hours and the choke should be kept outside the mass culture room. For mass culture, vigorous aeration should be provided.

4. CULTURE

Isolation, stock culture, mass culture and mixed algal culture can be done in the following manner.

4.1 Isolation of *Phytoplankton*

For the isolation of the required species of *phytoplankton*, the serial dilution culture technique is employed. In this method mainly 5 dilution steps (the inocula corresponding to 1, 10^{-1} , 10^{-2} , 10^{-3} and 10^{-4} ml) are employed. After filtering the sea water through 10 micron sieve, the filtrate has to be inoculated to 5 series of culture tubes in various concentrations. These are kept under sufficient light and with uniform temperature (25°C) conditions. After 15-20 days, discoloration of the tubes can be observed. On examination, the growth of unialgal species can be observed. Purification of these organisms can be done by sub-culturing the same in 250 ml, 500 ml, 1 l. and finally 3 or 4 7. Haufkin culture flasks as stock culture.

4.2 Stock Culture

Conway medium is used for the stock culture of the above algal. Cultures are maintained in 5 / Haufkin flasks. Nutrients are added along with 10 ml of inoculum and this is kept under illumination (1000 lux) in an air-conditioned room. When the exponential growth phase is reached in 8-10 days, the light intensity is reduced to half. The flagellates will enter into stationary phase after 15 days and it can be maintained for about 2 months with or without aeration. Before it enters into death phase, these cultures should be used as inoculum for carrying out mass production.

Solution A-Chemicals

Potassium nitrate	100 g.
Sodium orthophosphate	20 g.
Sodium EDTA	45 g.
Boric acid	33.4 g.
Ferric chloride	1.3 g.
Manganese chloride	0.36 g.
Distilled water	1000 ml.

Solution B-Trace metals

Zinc chloride	4.2 g.
Cobalt chloride	4.0 g.
Copper sulphate	4.0 g.
Ammonium molybdate	1.8 g.

Distilled water 1000 ml.
Acidify with HC1 to obtain a clear solution.

Solution C-Vitamins

Vitamin B (Thiamin) 200 mg.
Vitamin B₁₂ (cyanocobalamine) 10 mg.

Each vitamin is dissolved separately in 100 ml. distilled water and stored in a refrigerator.

Solutions A, B and C are prepared in different re-agent bottles. 1 ml. of A., 0.5 ml. of B, and 0.1 ml. of C each are added to 1000 ml. of filtered and sterilized sea water.

4.3 Mass Culture

Persepex tanks of 100 /. capacity are used for mass culture. Two litre inoculum is added per 100 /. of sea water Maximum algal bloom is obtained in 5-6 days. Vigorous aeration is provided.

4.4 Mixed Algal Culture

Mixed algae are produced in 1t. FRP tanks in the sunlight using filtered sea water. Algale from the indoor mass culture is used as inoculum. The mixed algae in the open may bloom in 3-4 days. This may contain a mixture of diatoms along with the *Isochrysis*. Chemicals used for open culture in 1000 /. of sea water are given below:

Potassium nitrate 13.2 g.
EDTA 6.6 g.
Sodium orthophosphate 6.6 g.
Sodium silicate 6.6 g.

Initially the stocks were maintained in test tubes. When we have sufficient test tubes of pure culture we have to sub-culture them in 500 ml. and in one litre conical flask. Then we have to sub-culture them into four-litre Haufkin's culture flasks. Twenty litres of sterilized sea water is taken in glass carbouys and enrich them with Walne's medium and to this 500 ml. of inoculum is added from Haufkins culture flask. Within four days a good bloom will be developed. This can be used as inoculum for the presepex tanks. For mass culture we take 60 litres of sterilized sea water and enrich the same with Walney's Conway's medium. For one litre of sterilized sea water 1 ml. of A and 0.5 ml of B are taken. We can harvest micro-algale within four days. When golden yellow colour develops, it indicates that it is a good bloom. Normally, cell concentration is around 1.2 to 2 million cells per ml. The cell concentration can be estimated with the help of haemocytometer.

5. PLAN OF WORK AND EQUIPMENT

The plan of work for the production of sea cucumber seed can be divided into three phases.

- i) Installation of equipment in the hatchery as per recommendations given in this report. All the additional equipment suggested may be procured. Sea water connection and aeration may be installed. The microalgal culture

laboratory may be made operational. All these works should be finished before the end of May'96.

- ii) The full fledged hatchery can be inspected in June 1996 to check and see whether everything is in order to make it fully operational.
- iii) Seed production of *Holothuria fuscogilva* can be first attempted in January 1997. This species seems to spawn without thermal stimulation. When specimens are collected from a depth of 30 to 40 m. and brought to the laboratory, due to the change in the environmental conditions, they spawn. When once the seed production of *Holothuria fuscogilva* is successful, the seed production in *Thelenota ananas*, another commercially important species, can also be taken up.

The consultant was provided with a list of equipment (Annex 1) drawn by the government and to be imported. He advised on the requirements for equipment and chemicals necessary for the sea cucumber hatchery (Annexes 2 and 3).

- W WELL
- ST SEDIMENTATION TANK
- FB FILTER BED
- SS STORAGE SUMP
- OT OVERHEAD TANK
- LT LARVAL TANK
- BT BROODSTOCK TANK
- UV U-V CHAMBER
- DC DRAINAGE CAN
- P PLATFORM
- SR STORE ROOM
- MCR MASS CULTURE ROOM
- SCR STOCK CULTURE ROOM
- GR GENERATOR ROOM
- CR COMPRESSOR ROOM

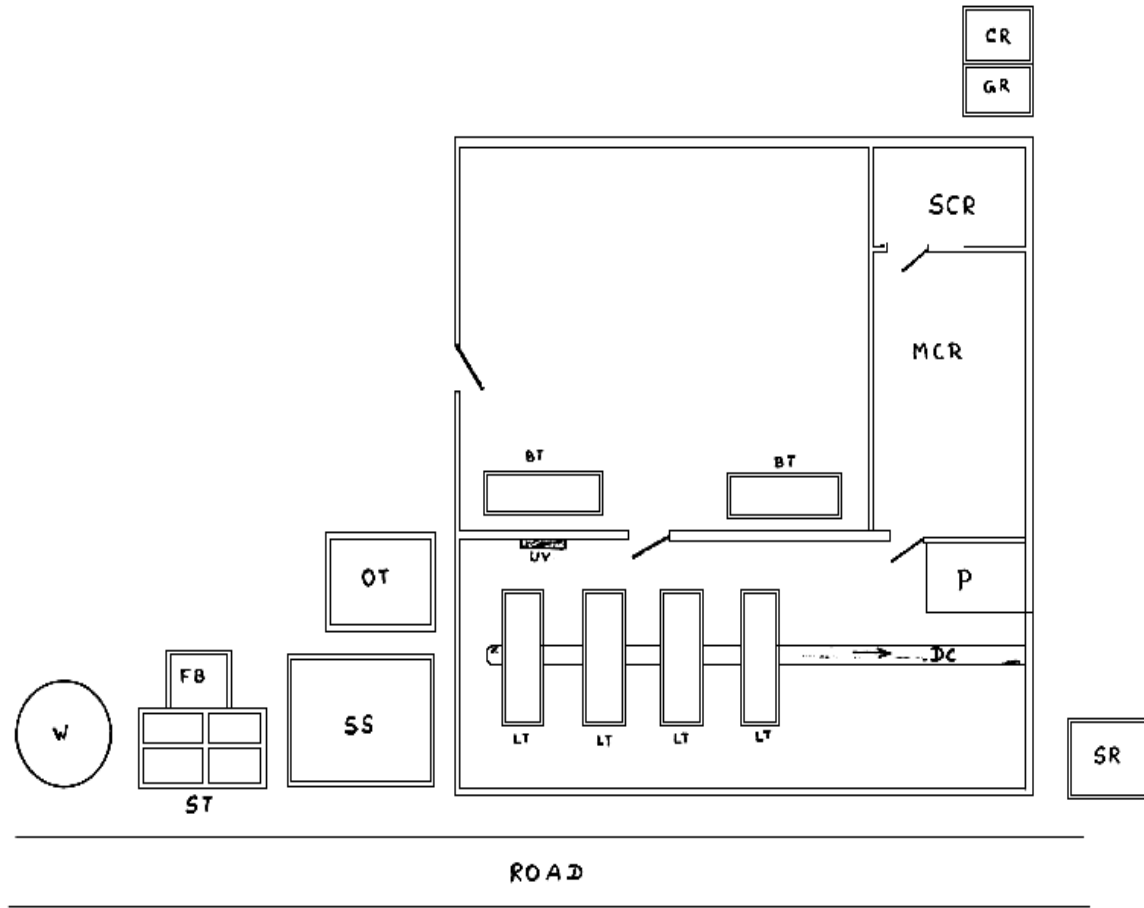

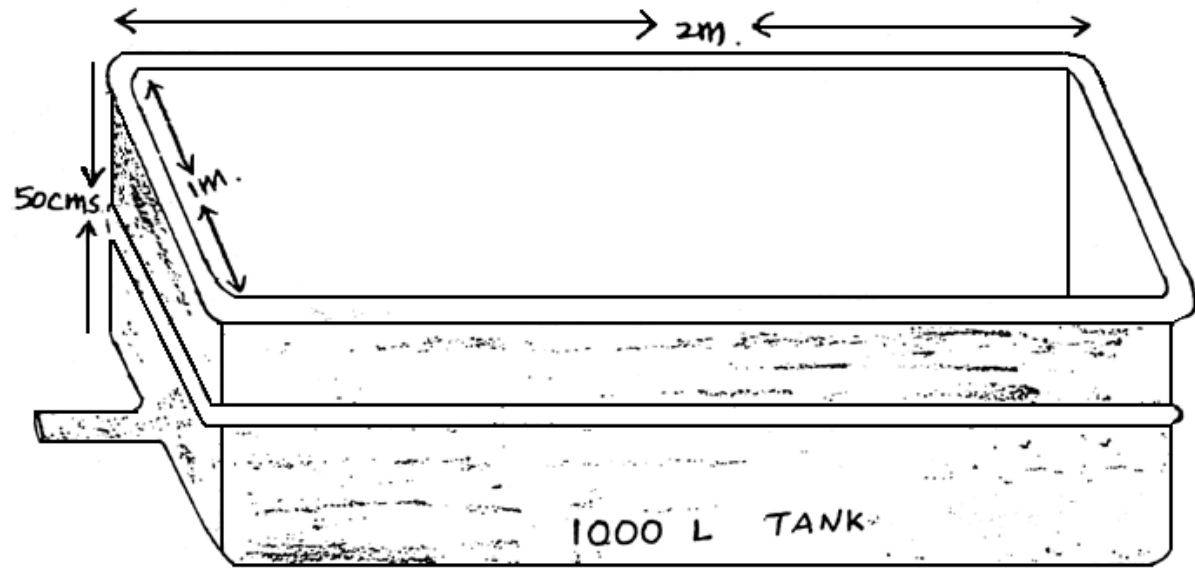

FIG - 2

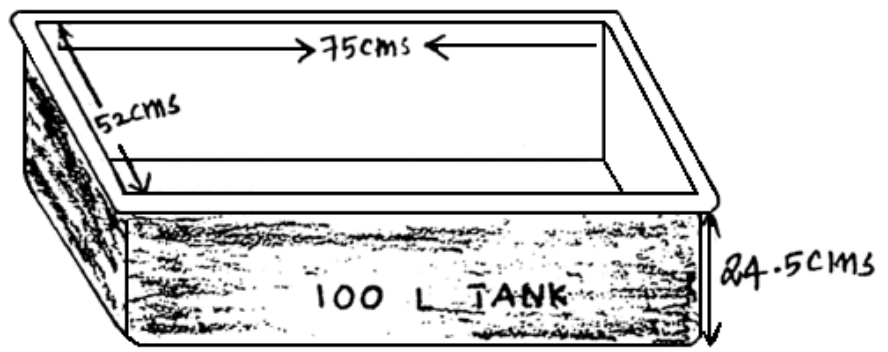

FIG 3

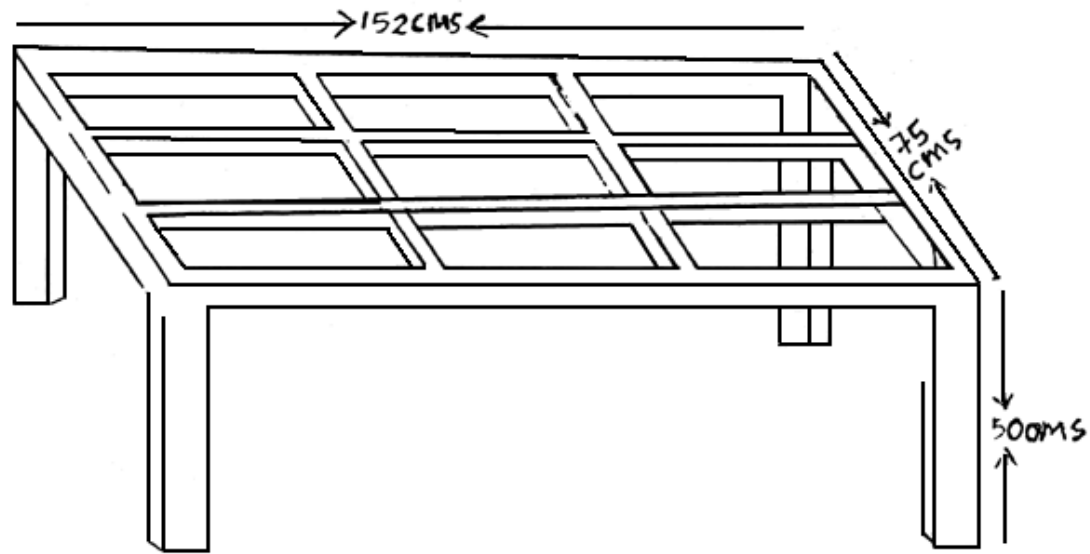

FIG. 4
WOODEN STAND FOR 100L. TANKS

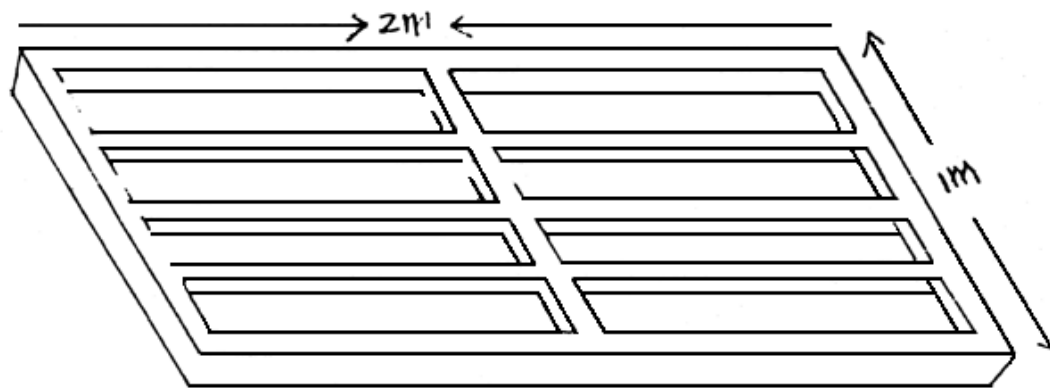

FIG. 5
WOODEN FRAME FOR 1000L. TANKS

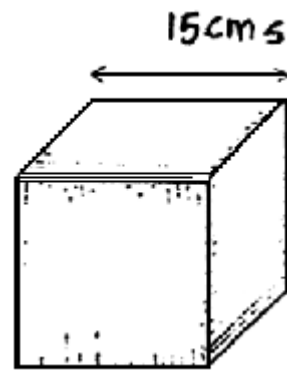

Fig - 6

STOCK CULTURE RACK

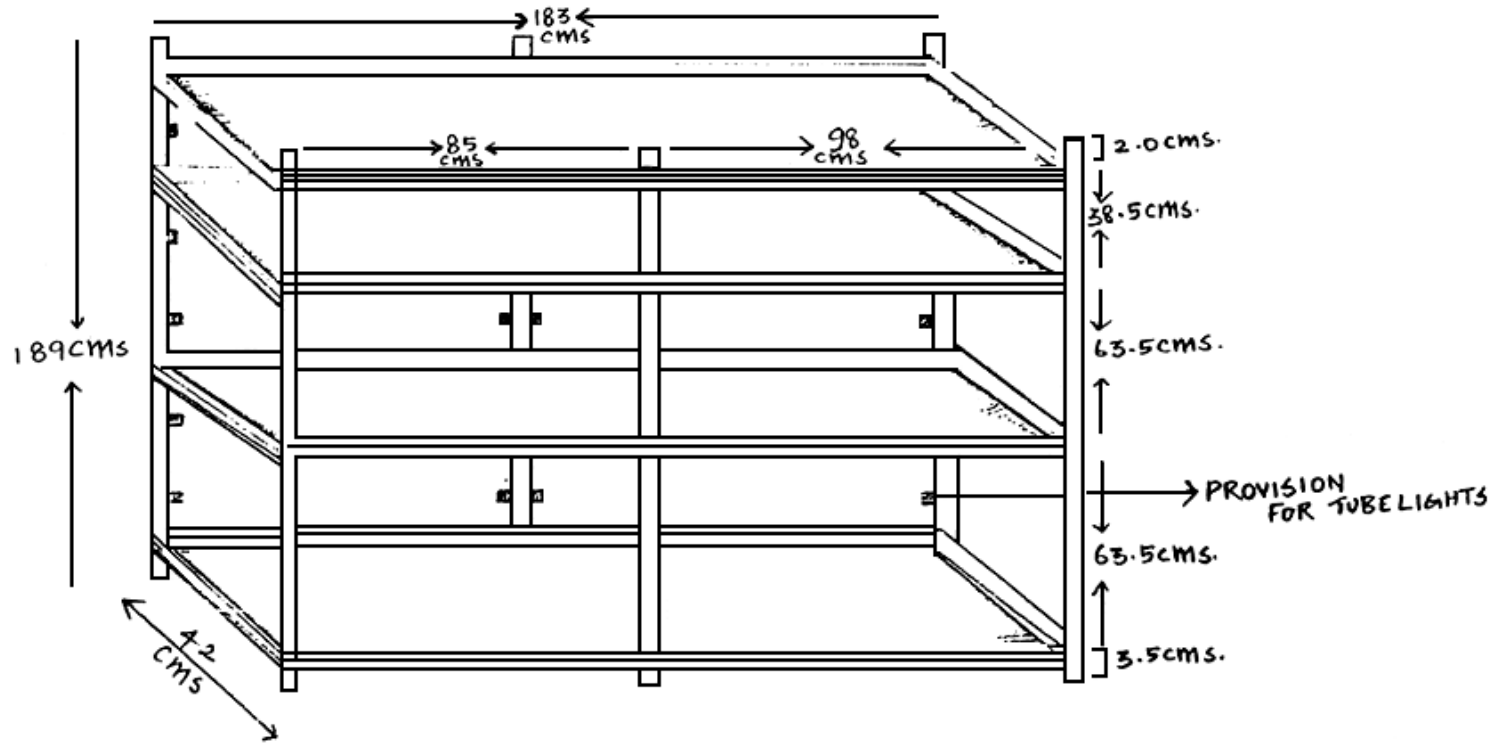
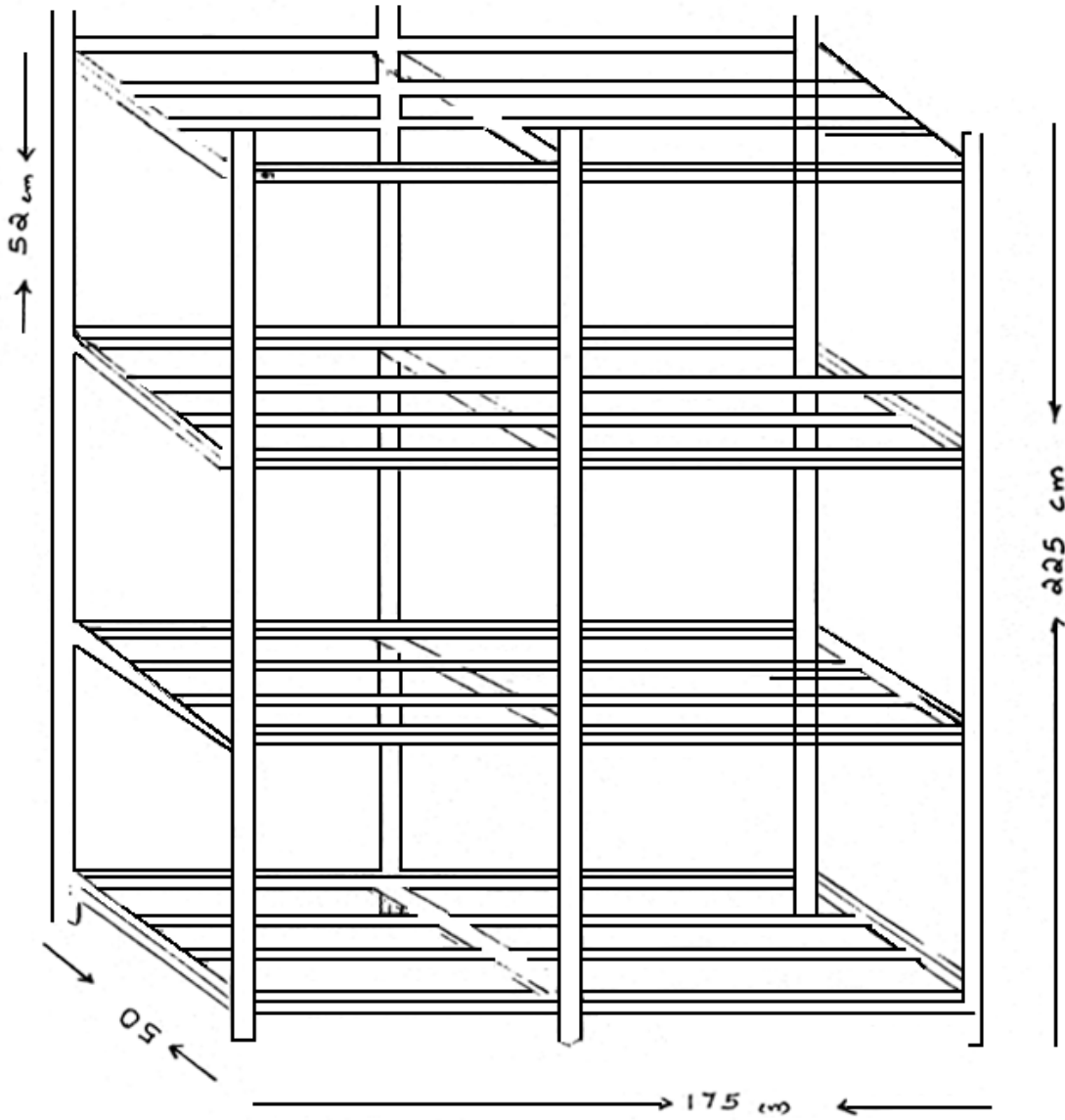

FIG -7



RACK FOR MASS CULTURE

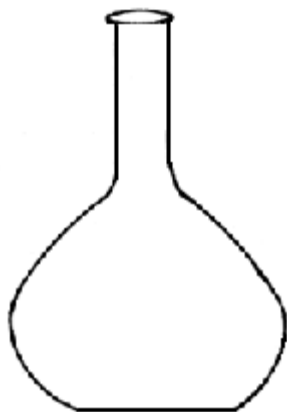

FIG. 8
HAUFKIN FLASK (4L)

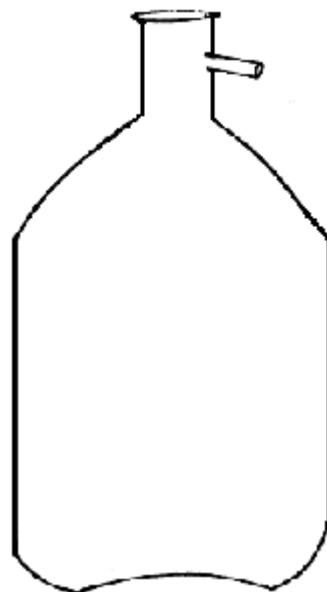

FIG. 11
GLASS CARBOUY (20L)

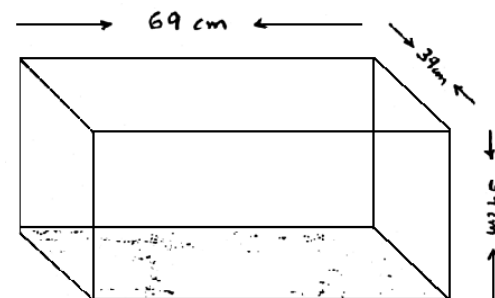

FIG. 10
PERSEPEX TANK (100L)

BUDGET DETAILS AND SUMMARY

ANNEX 1

SUMMARY BUDGET

<u>Component</u>	<u>Jan/Jun'95</u>	<u>Jul/Dec'95</u>	<u>Jan/Jun'96</u>	<u>Total</u>
Sea Cucumber:				
Equipment	23,000.00	0.00	0.00	23,000.00
Materials & Supplies	4,146.00	1,927.00	1,927.00	8,000.00
General Operating Costs	4,960.00	3,020.00	3,020.00	11,000.00
Personnel	7,200.00	10,400.00	10,400.00	28,000.00
Travel	1,500.00	750.00	750.00	3,000.00
Sub Total Sea Cucumber	40,806.00	16,097.00	16,097.00	73,000.00
Seaweed:				
Equipment	4,907.00	92.69	0.00	5,000.00
Materials & Supplies	0.00	2,000.00	2,000.00	4,000.00
General Operating Costs	0.00	1,000.00	1,000.00	2,000.00
Personnel	0.00	2,500.00	2,500.00	5,000.00
Travel	0.00	2,500.00	2,500.00	5,000.00
Sub Total Seaweed	4,907.00	8,092.69	8,000.00	21,000.00
COMBINED TOTAL	45,713.31	24,189.69	24,097.00	94,000.00

BUDGET DETAILS

	Allocation	Requires	Balance
PERSONNEL			
TCP (Sea Cucumber) Budget	28,000.00		
TCP Addendum (Seaweed) Budget	5,000.00		
Budget Line Total	33,000.00		
Salaries		5,700.00	
Food & Lodging for Local Staff		1,500.00	
Total for January to June		7,200.00	<u>25,800.00</u>

TRAVEL

TCP (Sea Cucumber) Budget	3,000.00
TCP Addendum (Seaweed) Budget	5,000.00

Budget Line Total	8,000.00
--------------------------	-----------------

Local Travel January to June	1,500.00	<u>6.500.00</u>
------------------------------	-----------------	------------------------

Equipment Imports	QTY	Unit Cost	US\$ Total
1. Reference Books	1	75.00	75.00
2. Dissecting Microscope	1	695.00	695.00
3. Compound Microscope	1	1,450.00	1,450.00
4. Beakers 1,000 ml.	12	3.06	36.72
5. Beakers 500 ml.	12	1.80	21.60
6. Beakers 600 ml.	12	0.85	10.20
7. Hand Counter	2	16.00	32.00
8. Graduated Cylinder 100 ml.	1	2.95	2.95
9. Graduated Cylinder 500 ml.	1	5.50	5.50
10. Hemocytometer	1	73.00	73.00
11. Top Loader Balance	1	185.00	185.00
12. Motor Cycle (50 to 90 cc.)	2	1,500.00	3,000.00
13. Kerosene Freezer	1	1,500.00	1,500.00
14. Aerators + Repair Kits	2	175.00	350.00
15. Dive Computer	1	300.00	300.00
16. Wet Suits (1 small, 1 large)	2	60.00	120.00
17. BOD Bottle, Clear Glass	4	8.15	32.60
18. BOD Bottle, Black Glass	1	11.75	11.75
19. CB Antenna	1	150.00	150.00
20. Hydrofoil	1	29.99	29.99
21. Desktop Computer	1	1,500.00	1,500.00
22. Laptop Computer	1	2,500.00	2,500.00
23. Printer	2	500.00	1,000.00
24. Solar Panels	9	369.00	3,321.00
25. Charge Controller for above	2	123.00	246.00
26. DO Meter	1	562.00	562.00

27. BOD Probe	1	445.00	445.00
28. Cap Membrane Kit	1	37.00	37.00
29. Outboard Motor (5 h.p.)	1	1,000.00	1,000.00
30. Mechanical Flow Meter	1	275.00	275.00
31. Autoclave	1	515.00	515.00
32. Sand Filter	1	65.00	65.00
33. Magnetic Stirrer	1	60.00	60.00
34. Fibreglass tanks	6	75.00	450.00
35. Light Meter	1	130.00	130.00
36. Battery Bank	1	1,000.00	1,000.00
37. Pumps	2	200.00	400.00

Total Imports (equipment)

21,587.31

ANNEX 2

LIST OF ADDITIONAL EQUIPMENT REQUIRED

Equipment/Facility	Quantity Required
Generator (10 KVA)	1
Mixie	1
Jumbo Thermometer (0–50°C)	1
Silica cased immersion heater	1
Air-conditioner 2 t. capacity	2
pH meter	1
Salino-refractometer (temperature compensated 0–50°C)	1
Thermometer (0–50°C)	3
Microscope with automatic exposure unit and 35 mm. camera	1
Microscope, stereo suitable for photo-micrography of larvae	1
Photographic films	as required
Spatula	10
Weighing boat	5
Scissors 10 cm.	5
Scissors 15 cm.	5
Forceps	5
Painting brush (0 size)	10

Laboratory Glassware:

Test tube 15 ml.		50
Test tube 30 ml.		12
Beaker 10,000 ml.		6
Beaker 5,000 ml.		6
Beaker 3,000 ml.		4
Beaker 250 ml.		6
Conical flask 250 ml.		17
Conical flask 500 ml.		12
Conical flask 1,000 ml.		12
Haufkin's culture flask 4,000 ml.		100
Glass carbouys 20 l.		10
Persepex tanks 100 l.		20
Volumetric pipettes (assorted sizes)		10
Burettes (10 ml.)		2
Burettes (50 ml.)		2
Embryo cups (50 × 50 mm.)		6
Micro-slides with cavity		2
Micro-slides		6 boxes
Cover slips		6 boxes

Plastic Ware:

Plastic buckets (15 l.)		6
Plastic buckets (5 l.)		6
Plastic buckets (3 l.)		6
Basins (20 l.) capacity		6
Poly ethylene flexible hoses (20 mm. dia)		50 m.
PVC pipes (150 mm. dia for sieves)		6
Polythene sheets (for mixed algal culture)		10 m.
Bolting silk cloth	40 microns	1 m.
	80 microns	1 m.
	140 microns	1 m.
	180 microns	1 m.
	200 microns	1 m.
Velong screen	1 mm. mesh	30 m.
	4 mm. mesh	30 m.

Tank cover cloth (black)	30 m.
Nylon rope (2 mm.)	10 kg.
Nylon rope (5 mm.)	20 kg.
Wooden pole (3 m. length)	50 nos.
Sea water drawing distribution grid made of 50 mm. and 25 mm. grid PVC pipelines and valves	as required
Aeration gride made of 25 mm. rigid PVC pipelines with copper nozzles, 5 mm. polythene tubes, plastic "T" joints and regulators and diffuser stones	as required

ANNEX 3

CHEMICALS REQUIRED FOR ONE YEAR

Equipment/Facility	Quantity Required
1. Potassium Nitrate	15 kg.
2. EDTA (Sodium)	8 kg.
3. Sodium dihydrogen orthophosphate	4 kg.
4. Boric acid	4 kg.
5. Ferric chloride	250 g.
6. Manganese chloride	100 g.
7. Sodium silicate	1 kg.
8. Thiamin hydrochloride	25 g. × 4
9. Cyanocobalamine	100mg. × 10

APPENDIX 1

**PUBLICATIONS ON TAXONOMY, ANATOMY, BIOLOGY
ECOLOGY, HATCHERY AND CULTURE OF COMMERCIAL
TROPICAL SEA CUCUMBERS**

1. Anonymous 1976. A study of the artificial breeding and cultivation of *Stichopus japonicus* (Selenka). Stud. Mar. Sinica., 11: 173-181.
2. Anonymous 1977. Raising sea cucumbers. China Pictoral, 6: 2.
3. Anonymous 1983. Takarao morise Kasamura namako (Artificial Production of Holothurian Larvae). Rep., 12: 200-204 (in Japanese).
4. Chang, F. and Others 1957. A preliminary report on the artificial rearing and propagation of *Stichopus japonicus* Selenka. Zoo 1. Mag., 2 (2): 65-73.
5. Chen, C.P. AND C.S. Chian 1990. Larval development of the sea cucumber *Actinopyga echinites* (Echinodermata : Holothuroidea). Bull. Inst. Zoo 1. Academic Sinica, 29(2): 127-133.
6. Inaba, D. 1937. Artificial rearing of sea cucumbers. Susan Kenkyushi, 35(2): 241-246 (in Japanese).
7. Ishida, M. 1979. Studies on production of juvenile sea cucumbers. Susan Shikenjo, pp. 1-17, 1977 (in Japanese).
8. James, D.B., M.E. Rajapandian, B.K. Baskar and C.P. Gopinathan, 1988. Successful induced spawning and rearing of the *Holothurian Holothuria (Metriatyla) scabra jaeger* at Tuticorin. Mar. Fish, Infor, Ser. T&E Ser. No. 87: 30-33.
9. James, P.S.B.R. and D.B. James 1993. Ecology, breeding, seed production and prospects for farming of sea cucumbers from the seas around India. Fishing Chimes 13 (3): 24-34.
10. James, D.B. 1994. An annotated bibliography on sea cucumbers. CMFRI Spl. Pub., No. 58: 1-80.
11. Anonymous, A.D. Gandhi, N. Palaniswamy and J.X. Rodrigo 1994. Hatchery techniques and culture of the sea cucumber *Holothuria scabra*. Ibid., No. 57: 1-32.
12. Anonymous and P.S.B.R. James 1994. Handbook on Indian sea cucumbers. Ibid., No. 59: 1-46.
13. Anonymous 1994. Seed production in sea cucumbers. Aqua International. 1(9): 15-26.
14. Anonymous 1995. Toxonomic studies on the species of *Holothuria* (Linnaeus 1767) from the seas around India. Part 1. J. Bombay Nat. Hist. Sci. 92(1): 43-62.
15. Anonymous 1995. Toxonomic studies on the species of *Holothuria* Linnaeus, 1767 from the seas around India. Part 2. J. Bombay Nat. Hist. Soc. 92(2): 190-204.
16. Shui X. and Other 1984. A study on artificial culturing of sea cucumber seed. The effect of artificially prepared feed for larval sea cucumber. Fish. Sci. 3(3): 18-23 (in Chinese).
17. Shigeaki Yanagibashi, Toyoshige Yanagisawa and Ken Kawasaki 1984. A study on the rearing procedures for the newly settled young of a sea cucumber, *Stichopus japonicus*, with special reference to the supplied food items. The aquaculture.

18. Shui X., Q. Hu and Y. Chen 1986. A study on technology for rearing of postlarvae and juveniles of sea cucumbers in high density tanks. *Ocean 1. Limnol. Sin.* 17(6): 513-520.
19. Shuxu X. and G. Gongchao 1981. Experiments on Southward Transplantation and Artificial Breeding of the Sea Cucumber (*Stichopus japonicus*) *J. Fish. China* 5(2): 147-155 (in Chinese).
20. Shui X.L. and Others 1985. Preliminary report on artificial ripening of parental sea cucumber. *Fish. Sci.* 4(3): 28-32 (in Chinese).
21. Takeo Imai, Denzaburo Inaba, Ryuthei Sato and Masayoshi Hatanaka 1950. On the artificial breeding of Japanese sea cucumber, *Stichopus japonicus* Selenka. *Bulletin of the institute for Agricultural Research, Tohoku University* 2.2.