



Food and Agriculture Organization
of the United Nations

Emergency Centre for Transboundary Animal Diseases



Questions & Answers handbook for **good management practices and biosecurity** in small and medium-scale poultry hatcheries

**QUESTIONS & ANSWERS HANDBOOK FOR
GOOD MANAGEMENT PRACTICES AND BIOSECURITY
IN SMALL AND MEDIUM-SCALE
POULTRY HATCHERIES**

Food and Agriculture Organization of the United Nations
Ha Noi, 2017

Contributors

Compiling team: Hoàng Thị Lan, Tạ Ngọc Sinh, Nguyễn Thị Tuyết Minh, Võ Ngân Giang

Technical consultation team: Scott Newman, Astrid Tripodi, Trần Thanh Vân, Bạch Thanh Dân, Trần Anh Tuấn, Nguyễn Duy Điều, John B. Carey

English editor: Laurie Gleeson, Scott Newman

Designer: Ki Jung Min

Cover photo © FAO

The designations employed and the presentation of material in this information product do not imply the expression of any opinion whatsoever on the part of the Food and Agriculture Organization of the United Nations (FAO) concerning the legal or development status of any country, territory, city or area or of its authorities, or concerning the delimitation of its frontiers or boundaries. The mention of specific companies or products of manufacturers, whether or not these have been patented, does not imply that these have been endorsed or recommended by FAO in preference to others of a similar nature that are not mentioned.

The views expressed in this information product are those of the author(s) and do not necessarily reflect the views or policies of FAO.

ISBN 978-92-5-109813-4

© FAO, 2017

FAO encourages the use, reproduction and dissemination of material in this information product. Except where otherwise indicated, material may be copied, downloaded and printed for private study, research and teaching purposes, or for use in non-commercial products or services, provided that appropriate acknowledgement of FAO as the source and copyright holder is given and that FAO's endorsement of users' views, products or services is not implied in any way.

All requests for translation and adaptation rights, and for resale and other commercial use rights should be made via www.fao.org/contact-us/licence-request or addressed to copyright@fao.org.

FAO information products are available on the FAO website (www.fao.org/publications) and can be purchased through publicationssales@fao.org

CONTENTS

1. What are the problems we often encounter in a poultry hatchery?	1
2. What are the reasons for a low rate of embryos in eggs?	2
3. What are the reasons for dead embryos at an early incubation stage?	3
4. What are the reasons for rotten, exploded eggs during incubation?	4
5. What are the reasons for a high rate of piped eggs that do not hatch?	5
6. What are the reasons for a prolonged hatching time?	6
7. What are the reasons for complete hatch failure?	7
8. What are the reasons for crippled and malformed chicks and rough or unhealed navels upon hatching?	8
9. What are the reasons for dirty chicks upon hatching?	9
10. Reasons for high chick mortality during the first week	10
11. What is a standard egg for hatching?	11
12. It is said that an overweight parent flock will lead to a low hatching rate. Is that true?	12
13. How does one ensure collection of clean eggs?	13
14. Why should we avoid setting dirty eggs for incubation?	14
15. Why should the bigger end of the eggs be up when placed in incubation trays?	15
16. Why should we exclude eggs with big air cells, slanting air cells and detached, mobile air cells for incubation	16
17. How to recognize eggs that have been stored for too long	17
18. What is necessary to store eggs properly?	18
19. Why eggs stored in cold or air-conditioned rooms should not be placed in incubators right away?	19
20. How can eggs be stored for incubation if there are no storage rooms?	20
21. Why should eggs not be stored below 12 ^o C?	21
22. What are the optimal incubation parameters for duck eggs?	22
23. What are the optimal incubation parameters for Muscovy duck eggs?	23

24. Why do waterfowl eggs (ducks, Muscovy ducks, geese...) need cooling during incubation?	24
25. What should be done to cool waterfowl eggs during incubation?	25
26. What are the optimal incubation parameters for chicken eggs?	26
27. Why is the temperature in the early incubation stage higher than later stages?	27
28. What happens if eggs are not turned regularly?	28
29. Is there a different hatchability if different chicken egg batches from different farms are set in the same incubator with the same incubation parameters?	29
30. Can examining hatched eggs give an indication of the humidity level during incubation?	30
31. During incubation and hatching, which phase needs more ventilation?	31
32. Why do the hatchery houses, the incubators and hatchers need to be ventilated?	32
33. Which are the major pathogens contaminating hatcheries?	33
34. How do pathogens penetrate into hatcheries?	34
35. What is the anatomy of a poultry egg?	35
36. How do pathogens penetrate into eggs?	36
37. How do chicks contract diseases at hatcheries?	37
38. Why do we have to implement good biosecurity practices and in hatcheries?	38
39. What are the benefits of good biosecurity practices and in hatcheries?	39
40. What are the main bio-security principles?	40
41. Why do we have to implement the principle of segregation and movement control?	41
42. Why do we have to implement the principle of cleaning?	42
43. Why do we have to implement the principle of disinfection?	43
44. Why do we have to separate incubation and hatching areas from people's living areas?	44

45. Why do we have to separate incubation and hatching areas?	45
46. Why do we have to separate incubators and hatchers?	46
47. Can people bring pathogens into hatcheries?	47
48. Why do we want to keep rodents out of hatcheries?	48
49. Why do we always have to keep hatcheries clean?	49
50. How should you arrange incubating and hatching areas?	50
51. What are some best management practices for the egg arrival area?	51
52. How should an incubation area be cleaned and disinfected ?	52
53. How should a hatching area be cleaned and disinfected ?	53
54. Why should the hatching shelves be raised above the ground?	54
55. How should a chick delivery area be cleaned and disinfected?	55
56. What are the benefits of disinfection?	56
57. What leads to disinfection failure?	57
58. What are the recommended egg cleaning and disinfection methods?	58
59. When is the best time to disinfect eggs?	59
60. What should be noted when eggs are fumigated?	60
61. What should be noted if eggs are disinfected by washing or spraying	61
62. How should detergents and soap in hatcheries be used?	62
63. How should Ammonium Quaternary Compound (Quats) disinfectants be used in hatcheries?	63
64. How should Phenolic disinfectants be used in hatcheries?	64
65. How should Iodophors disinfectants be used in hatcheries?	65
66. How should Glutheraldehyde disinfectants be used in hatcheries?	66
67. How to use a combination of Glutheraldehyde and Ammonium Quaternary disinfectants in hatcheries?	67
68. What protective clothing should we wear when using disinfectants, in order to ensure our safety?	68
69. How can we ensure that spraying disinfectants in the hatchery is effective?	69
70. How to calculate the correct amount of disinfectant?	70

71. An example of calculating the correct amount of disinfectant	71
72. What are the principles for the correct spraying of disinfectants?	72
73. What to pay attention to when spraying disinfectants in hatcheries	73
74. How should Formalin with Potassium permanganate be used for fumigation? What should we note before using it?	74
75. What are the requirements for a fumigation cabinet?	75
76. What are the proper egg fumigation procedures when using formalin and potassium permanganate?	78
77. Are the chemicals used in hatcheries dangerous for humans?	79
78. What is it important to properly clean and disinfect the hatchery?	80
79. How should eggshells and dead chicks be disposed?	81
80. What production data the hatchery need to record?	82

ACKNOWLEDGEMENTS

Special thanks to Yonathan Segal as much of the information in this handbook is based on his lectures on biosecurity, cleaning and disinfection.

Gratitude is extended to FAO technical consultants and staff members for their contribution in the handbook development.

This guide was made possible thanks to the financial support provided by the World Poultry Foundation (WPF).



1. What are the problems we often encounter in a poultry hatchery?

- Low hatching rate.
- Low rate of eggs with embryos.
- Many embryos dead at an early incubation stage.
- High rate of rotten eggs during incubation.
- Piped eggs, without hatching.
- Late hatching or chicks not hatching at the same time.
- Complete hatch failure
- Poor quality of day-old birds:
 - 1) Chicks hatch with crippled and malformed legs.
 - 2) Chicks hatch with rough or unhealed navel, wet and dirty feathers.
 - 3) High mortality during the first week of life.



2. What are the reasons for a low rate of embryos in eggs?

Low rate of embryos in eggs is often caused by:

- The male-female rate of the parent flock is not suitable: insufficient or excessive number of roosters.
- Imbalance of maturity or size between males and females also affects mating success.
- Spurs are not trimmed causes severe scratching of hens and then hens will run from mating attempts or roosters have malformed toes making it difficult for them to keep balance on the back of the hens during mating.
- Improper design of the breeding house, affecting the roosters and drakes.
- The way from the shed to the duck pond should be smooth, not too inclined or steep, and should not have any stairs to avoid damaging the sexual organs of the drakes.
- The parent flock is diseased.
- Improper feeding practices of the parent flock leading to overweight or late sexual maturity (especially for roosters).
- Inadequate space – crowding also creates problems.
- Too much space can also reduce successful matings.
- Mite or ectoparasite infestations dramatically affect male fertility.



3. What are the reasons for dead embryos at an early incubation stage?

Dead embryos at early stage can be caused by:

- A diseased parent flock.
- Improper nutrition of breeders e.g. the use of mouldy feed or feed lacking micronutrients
- Eggs are cracked, dirty or wet.
- Improper egg cleaning and fumigation.
- Eggs stored improperly or for too long before incubation.
- Improper incubation parameters such as too high or too low temperature or humidity or insufficient egg turning during the incubation period. (See questions number 21, 22 and 25 for more details on proper temperature, humidity and turning rate)
- Inbreeding can cause early embryonic mortality.



4. What are the reasons for rotten, exploded eggs during incubation?

Eggs can become rotten or explode due to the following reasons:

- Eggs become infected with infectious diseases from the parent flock (Salmonella bacteria).
- Wet and dirty bedding or laying nests leads to infections of the egg with bacteria (e.g. Pseudomonas, E.coli, etc.).
- Eggs have been wet prior to setting.
- Improper egg cleaning procedures
 - a) Cleaning eggs in water which has a lower temperature than that of eggs
 - b) Cleaning eggs with a disinfection solution that has been prepared incorrectly not following the manufacturer recommendations.
- High air humidity during egg storage.(See proper humidity in the question No 17)
- Contamination during storage. Activities like sweeping or spraying water on the floor of the egg storage area can deposit large amounts of bacteria on the eggs.
- Failure to clean incubators following an egg explosion leaves bacteria in the chamber that can contaminate other eggs.



5. What are the reasons for a high rate of piped eggs that do not hatch?

Piped eggs might not hatch due to the following reasons:

- Eggs have been stored for too long or at too low or too high a temperature before incubation. (See proper time and temperature in the question No 17)
- Improper setting of eggs in incubation trays with the small end up.



Piped eggs might not hatch due to setting the smaller end of the eggs up

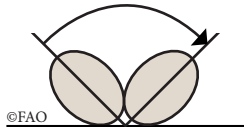

Proper turning angle of eggs in the incubator is 90°

- Wrong turning angle of the egg in the incubator
- Improper incubation parameters: too high or too low temperature or humidity or insufficient egg turning during the incubation period. (See questions number 21, 22 and 25 for more details on proper temperature, humidity and turning rate)
- Improper ventilation during any or all of the incubation period, and especially during hatching.
- Improper nutrition of breeders: the use of mouldy feed or feed lacking micronutrients
- Parent flock is diseased (Salmonellosis, Mycoplasmosis, Colibacillosis)
- Inbreeding can cause weak chicks resulting in higher pips.
- Rough handling when eggs are transferred from the incubator to the hatcher can cause mal-positioned embryos that will pip but not hatch. (Eggs should be put in one layer in hatching trays of not high density to allow the eggs to rotate during pipping).



6. What are the reasons for a prolonged hatching time?

Prolonged hatching time is caused by the following reasons:

- Eggs have been stored for different duration.
- Eggs have been stored for too long before setting (see details on proper egg storage duration in the question No 17).
- Different egg sizes and/or breeder ages.
- Embryos have already started developing during egg storage prior to setting.
- Low temperature at the initial stage of incubation (lower than 37.2°C).
- Uneven egg temperature at time of setting – some eggs warm others cool.
- Different genetics within the eggs set.



7. What are the reasons for complete hatch failure?

Causes could be power failure, low or high temperature, eggs stored incorrectly, old eggs and equipment failure (fans, ventilation, etc.)



8. What are the reasons for crippled and malformed chicks and rough or unhealed navels upon hatching?

The main reasons for crippled and malformed legs, and a rough or unhealed navel upon hatching are as follows:

- Improper incubation temperature, usually too high (higher than 38°C) during the second phase of incubation period and the hatching time.
- The eggs are placed with the small end up.
- Improper nutrition of breeders: feed lacks micronutrients and/or is mouldy or aflatoxin-contaminated.
- The parent flock has been improperly treated with veterinary drugs
 - a) Wrong medication, or
 - b) Higher doses than recommended by manufacturers
- Bacterial contamination of the yolk sac – omphalitis
- Vitamin deficiencies in the breeders
- Inbreeding
- Hatch tray surfaces are irritating chicks – no paper or wrong type of paper. Slick paper in hatch tray can cause spraddle-legged chicks, rough paper can irritate navels.



9. What are the reasons for dirty chicks upon hatching?

Main reasons for dirty chicks upon hatching are:

- The humidity in the incubators and hatchers was too high that adversely affected the embryo development leading to those eggs pipped but died without hatching and produced a fluid making other chicks dirty (see an illustration picture below).



- Rotten eggs are not removed when they explode in the hatching trays and other eggs and chicks get dirty.
- Rough handling during transfer of eggs from incubator to hatcher – broken, cracked and leaking eggs.
- Chicks left in hatcher too long.
- The parent flock is diseased (Salmonellosis, Mycoplasmosis, Colibacillosis).



10. Reasons for high chick mortality during the first week

In the first week, a high mortality rate of chicks is mainly due to:

- The temperature is too low (below 20°C) in the brooding house and they more easily get infections.
- Drafty/cold areas in the brooding pen.
- Brooding pen too large – chicks get away from heat and are not able to get back.
- Diseases are transmitted vertically from hens to chicks (Salmonellosis, Mycoplasmosis).
- Hatching of the whole batch of eggs takes too long. Those chicks that hatch early get dehydrated and become weak. (See question number 6 for more details)
- Chicks are given feed and drinking water too late after they arrive in the farm.
- Chicks are given feed before drinking water.
- Water temperature too cold – especially day one.
- Feeders and/or waterers are not adjusted properly – too high
- Brooding pen too crowded – inadequate brooder, drinker and feeder space
- Failure to start to drink and/or eat.
- Litter eating
- Transportation takes too long, or the temperature during transport is too hot or too low (Optimal temperature range for chick transport of 22-28°C).



11. What is a standard egg for hatching?

A hatchery standard egg is:

- An egg that comes from a parent flock that is bred properly according to good production practices including a proper male/female ratio according to the technical requirements of each species or breed including proper body weight and fed with a nutritionally appropriate feed – good quality.
- Proper weight, not too big, not too small (note that the weight depends on species and breed as some examples in the table below).

No	Poultry breed	Egg weight (g)
1	Ri chicken	45 - 48
2	Lương Phượng chicken	53 - 58
3	Hyline Brown chicken	60 - 65
4	Triết Giang duck	55 - 60
5	Bầu duck	75 - 80

- Typical (not malformed) shape and color
- Has never been dirty – scraping manure or dirt off the shell does not make the egg clean.
- The shell is not rough, not too thick and not too thin
- No blood stains or cracks in the egg



12. It is said that an overweight parent flock will lead to a low hatching rate. Is that true?

Yes!

Mating success of overweight males is much lower. Reproductive “season” of overweight males is much shorter.

Overweight females also have erratic laying patterns, affecting quality of the eggs.



13. How does one ensure collection of clean eggs?

In order to collect more clean eggs, it is necessary to:

- Keep the breeder house clean.
- Keep litter in the house dry and clean – remove and replace areas that get wet.
- Maintain sufficient laying nests in appropriate locations (quiet places; avoiding direct sunshine, easy-to-find locations).
- Train hens to lay eggs in nests, minimizing egg lay on the floor.
- The litter and bedding for the nests must be kept dry and clean.
- Nest should be kept clean from feces and dirt. Regularly collect eggs (average 4 times/ day) and arrange them in clean trays.
- Use only clean, undamaged trays or packing materials.
- Always place eggs in trays with the bigger end up
- Do not put the eggs in baskets as they can easily crack.
- Clean egg storage area only when there are no eggs present. Sweeping and/or spraying while eggs are present will increase egg contamination.
- Make sure hands of workers handling eggs are clean. Do not handle eggs after working with dead or diseased birds, manure or other contaminants without first washing your hands.



14. Why should we avoid setting dirty eggs for incubation?

Dirty eggs can get soiled with feces when hens have diarrhea, or from feces and dirt in wet litter or nests. Ectoparasite infestations also can cause dirty eggs.

These eggs should not be incubated because:

- Transmission of pathogens to clean eggs can occur in incubators.
- Dirty eggs may rot or explode, thus contaminating the incubator and affecting the hatching quality of the whole batch of eggs.
- Dirty eggs normally have a very low hatching rate.
- Bacteria on contaminated eggs can be passed to hatched chicks.



15. Why should the bigger end of the eggs be up when placed in incubation trays??

- Embryo will have the proper orientation within the shell.
- The air cell of the egg is at the bigger end of the eggs and having this end up facilitates the respiratory process of the embryos.

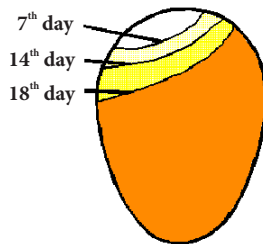

Size of air cell on 7th, 14th and 18th day of incubation

- Upon hatching, pipping will be easier as the eggshell at the bigger end is thinner than at the smaller end.

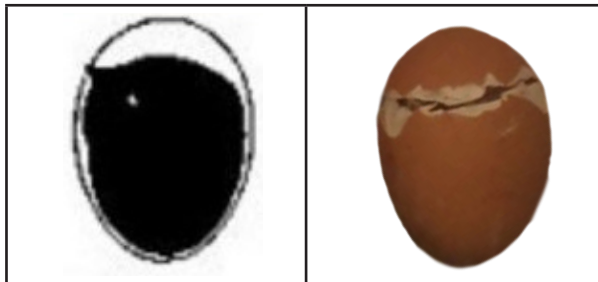

Proper pipping

- Eggs will crack less often during the turning process of incubation if the bigger end of the egg is up.



16. Why should we exclude eggs with big air cells, slanting air cells and detached, mobile air cells for incubation

When selecting eggs for incubation through candling, eggs with big air cells, slanting air cells and mobile air cells should be excluded because:

- Eggs with big air cells have been stored for a long time or under improper conditions (humidity is too low) and have poor hatching success.
- If the air cells are too slanted, the embryos can develop at the wrong location in the egg leading to low hatchability.
- Detached, mobile air cells mean that the outer and inner egg membrane has been separated and leads to low/no hatchability. This is often caused by transport on rough roads or rough handling during movement on and off transportation vehicles or if eggs are stored with the small end up.



17. How to recognize eggs that have been stored for too long

Eggs stored for a long time (more than 7 days) often have the following characteristics:

- The eggshells are glossy.
- Big air cells are seen upon candling.
- The yolks move quickly upon egg rotation.
- The yolk can stick to one end of the egg, which can be seen upon candling.



18. What is necessary to store eggs properly?

To ensure high hatchability and healthy chicks, eggs for incubation must be stored properly:

- Handle eggs carefully ever time they are moved.
- Eggs must be kept in a well ventilated, dry, clean area.
- The storage room must be maintained at a proper temperature and humidity so that egg will not be rotten and embryos will not die or develop too early.
- Avoid storing other items with the eggs – may increase contamination.

This table shows the most suitable temperature and humidity:

Storage duration	Temperature (°C)	Humidity (%)
7 days	15-18	75-80
4 days	18-24	75-80

- Do not store eggs in temperatures below 12°C and over 26°C.
- Store eggs as soon as possible to avoid early embryo development.
- Do not store eggs for more than 7 days



19. Why eggs stored in cold or air-conditioned rooms should not be placed in incubators right away?

- Eggs stored in cold or air-conditioned rooms should not be placed in incubators right away to avoid temperature shock that can lead to a high ratio of dead embryos.
- Eggs taken out of air-conditioned rooms can “sweat” and should be left outside to warm up until the shells are dry before setting them into the incubators.



Egg sweating



20. How can eggs be stored for incubation if there are no storage rooms?

If there are no storage rooms:

1. Move eggs directly to incubation – do not cool them down at this point.
2. Store eggs as follows:
 - Eggs must be kept in ventilated, dry, clean areas without direct sunlight.
 - Eggs should be set in trays, not placed on top of one another.
 - Eggs should not be stored for more than 3 days if the temperature is over 30°C.



21. Why should eggs not be stored below 12°C?

There will be greater potential for sweating problems at the time the eggs are set.

If egg storage is too cold, embryos will not “re-start” cell division at incubation and thus will not hatch.



22. What are the optimal incubation parameters for duck eggs?

The optimal incubation parameters for duck eggs are as follows:

Day	1-3	4-7	8-13	14-24	25	26-28
Temperature (°C)	37.6-37.8		37.3-37.5		37.2-37.4	
Humidity (%)	56-58		54-56		52	68-72
Egg turning	- For industrial incubators : Turning once every hour (machine turning) - For manual turning: at least once every 3 hours					
Cooling* (taking eggs out of the incubator for incubators without automatic cooling system)		Once per day	Once per day	Once or twice per day		



23. What are the optimal incubation parameters for Muscovy duck eggs?

The optimal incubation parameters of incubation for Muscovy duck eggs are as follows:

Day	1-3	4-7	8-15	16-30	31	32-34
Temperature (°C)	37.6-37.8		37.5-37.7		37.0-37.2	
Humidity (%)	56-58		54-56		52	68-72
Egg turning	- For industrial incubators : Turning once every hour (machine turning) - For manual turning: at least once every 3 hours					
Cooling* <i>(taking eggs out of the incubator for incubators without automatic cooling system)</i>		Once per day	Once per day	Twice per day		



24. Why do waterfowl eggs (ducks, Muscovy ducks, geese...) need cooling during incubation?

Waterfowl eggs need cooling during incubation due to waterfowl biology: while incubating eggs, the female birds leave the nest to search for food and then return to continue incubation. Waterfowl eggshells are adapted to this process and the change of temperature. Through evolution more recent domestication, some domestic ducks gradually lost this habit. However, the structural characteristics of the eggs remain the same: bigger weight, durable shell structure, hard to break upon hatching (different from chicken eggs and eggs from other avian species).

In artificial incubation, the cooling of waterfowl eggs (by spraying water on the surfaces of the eggs) is important as it will soften the membrane under the shell and make the shell crisp which makes it easier for the piping process before hatching.



25. What should be done to cool waterfowl eggs during incubation?

Implement the following steps (applying for locally made incubators):

1. Take the eggs out of incubators.
2. Turn the eggs 120° - 180°.
3. After turning eggs on each tray, spray gentle mist of water directly on the surface of the eggs.
4. The temperature of the cooling water depends on the weather, but should be between 30°C and 37°C
5. Cooling time is between 5 - 15 minutes.



26. What are the optimal incubation parameters for chicken eggs?

The optimal incubation parameters for chicken eggs in single stage locally made incubators are as follows:

Day	1 - 5	6 - 18	19 - 21
Temperature (°C)	37.8-38.0	37.5-37.7	37.2-37.0
Humidity (%) (broiler)	54-56	51-53	58-60
Humidity (%) (layers)	53-55	50-52	56-58
Egg turning	- For industrial incubators : Turning once every hour (machine turning) - For manual turning: at least once every 3 hours		



27. Why is the temperature in the early incubation stage higher than later stages?

During incubation, the temperature in the early stage should be higher than later stages. In the early stage, embryos need to absorb heat provided by incubators to develop properly. Low temperatures in this stage will result in the poor development of embryos. (Note that, the temperature should not be over 38°C as high temperatures will kill the embryo).

In the later stages, the embryos are actually producing heat so the main function of the incubator or hatcher is to provide uniform ventilation to evenly remove this heat. At times, the heating circuit will come on due to the low temperature of the outside air entering the incubator or hatcher.



28. What happens if eggs are not turned regularly?

If eggs are not turned regularly and sufficiently, embryos will stick to the outer membrane, resulting in dead embryos, poor hatching, or weak chicks. Yolks can also stick to the shell, which will result in embryos that cannot hatch due to inability to absorb the yolk sac and/or inability to extract adequate nutrients from the yolk sac.



29. Is there a different hatchability if different chicken egg batches from different farms are set in the same incubator with the same incubation parameters?

Yes! Egg batches from different farms can show different hatchability even if incubated together in the same incubators with the same incubation parameters. Different farms supply eggs of different quality due to:

- A different quality of the breeders, production management, or male/female ratio of the parent flock
- Different health status of the parent flocks.
- Different egg collection and storage conditions at farm level.
- Age of the breeders and/or egg size influence hatch rate. Genetics also can play a role.
- The amount of pre-incubation (early embryonic development prior to egg storage) will influence hatch time.



30. Can examining hatched eggs give an indication of the humidity level during incubation?

A proper humidity level in the incubator is reflected through good development of the embryo and proper hatching.

Through the observation of the pipping site, the correct incubator humidity can be evaluated. If most of chicks pip at a location on the egg between the bigger end and the equator, this means that evaporation during incubation was good and the humidity in the incubator is suitable.

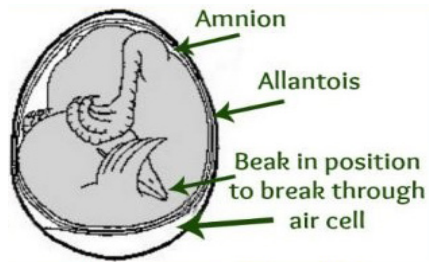

Proper pipping

- If chicks mostly pip at the top of the bigger end of the egg it indicates that evaporation was limited and the humidity in the incubator was too high and needs to be adjusted.
- If chicks mostly pip at a location on the egg between the equator and the smaller end, it indicates that evaporation was higher than normal and the humidity in the incubator is too low and needs to be adjusted.



31. During incubation and hatching, which phase needs more ventilation?

During the hatching period and especially during piping, more ventilation is required because the embryo starts to use its lungs to breathe. Therefore, they need more oxygen. Lack of oxygen during this period can lead to the death of chicks.

Therefore, it is particularly important to ensure that incubators and hatching rooms are well ventilated to ensure sufficient oxygen for chicks. Using exhaust and circulating fans will help.



32. Why do the hatchery houses, the incubators and hatchers need to be ventilated?

Be aware that there are literally hundreds if not thousands of living, breathing chicks in a relatively small space. Proper exchange of air assures adequate oxygen and removal of harmful gasses. Thus, if the hatchery is not well ventilated, this will have negative impacts to the development of embryos and result in low hatchability and poor quality of chicks. Ventilation will also create a healthy work environment in the hatchery.



33. Which are the major pathogens contaminating hatcheries?

- + Vertical transmission from the hens can cause Salmonellosis and Mycoplasmosis;
- + Horizontal transmission due to contamination in the hatchery can cause Bacterial Diseases; E. coli resulting in dead embryos and chicks, Pseudomonas resulting in rotten eggs, egg explosion, omphalitis, and Staphylococcus, etc.
- + Viral Diseases: Mareks disease, Newcastle disease, Duck Plague, etc.
- + Fungal Diseases: Aspergillus fumigatus



34. How do pathogens penetrate into hatcheries?

Pathogens can enter into hatcheries through the following ways:

- Eggs from diseased parent flocks.
- Dirty eggs (due to wet, dirty litter).
- Vehicles used for transportation are not clean or disinfected properly.
- Fumigation or incubation equipment and tools are not clean and disinfected properly.
- Items other than hatching eggs stored with the eggs. Do not store any other items with the eggs.
- Ventilation may bring in contamination. For example if the air inlets of the hatchery are near the feed mill, mold or other airborne contaminants can be drawn into the hatchery by the ventilation system.
- Water used for cleaning contains pathogens.
- People working at or visiting the hatcheries have not washed their hands, or clothing changed or disinfected footwear and has not used other protective clothing.
- Hatchery is not biosecure and animals, rodents or insects can enter and contaminate the hatchery



35. What is the anatomy of a poultry egg?

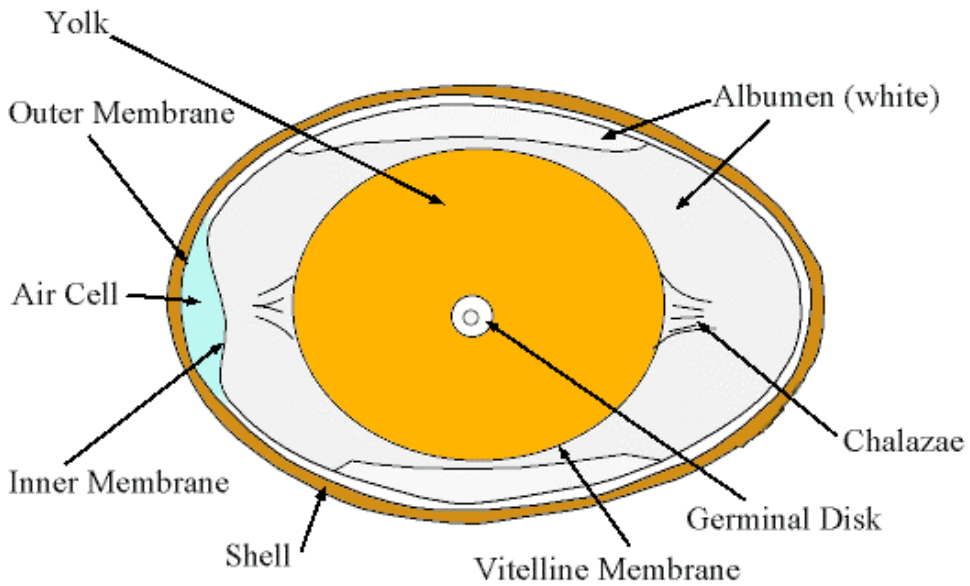

Anatomy and structure of a poultry egg



36. How do pathogens penetrate into eggs?

Pathogens penetrate into eggs through the following ways:

- Horizontal transmission (from the outside): pathogens can enter the egg through air pores or cracks in the shells.



- Vertical transmission (from hens to chicks): hens can infect chicks by vertical transmission.
- Improper washing can actually cause pathogens to enter the egg.
- Scraping manure or stains off the eggshell with a blade or sandpaper will increase pathogen entry into the egg.
- There may also be genetic characteristics that increase susceptibility in some breeds. Inbreeding reduces the ability of the chicks to fight off pathogen attacks.



37. How do chicks contract diseases at hatcheries?

Chicks contract diseases at hatcheries through the following routes:

- Through the respiratory route from inhaling pathogens and fungal spores in the air (Salmonella, Mycoplasma, Aspergillus).
- Through navels which have not yet closed.
- Vertically from parents to the chicks inside the eggs (Salmonella, Mycoplasma).
- Pathogens passing through egg shell pores or cracks due to:
 - 1) Improper washing can actually cause pathogens to enter the egg.
 - 2) Scraping manure or stains off the eggshell with a blade or sandpaper will increase pathogen entry into the egg.
 - 3) Items other than hatching eggs stored with the eggs.
- Cross-contamination in incubators and during hatching process through rotten eggs, exploded eggs, dirty eggshells or feather.
- Contaminated hatchery equipment, tools or workers



38. Why do we have to implement good biosecurity practices in hatcheries?

Good biosecurity practices and in hatcheries help:

- Minimize the level of pathogen contamination in hatcheries.
- Minimize cross contamination between clean areas (eggs storage and incubators) and dirty areas (hatching, packaging and chick delivery).
- Avoid pathogen transmission from hatcheries to poultry farms.
- Minimize the establishment of a pathogen reservoir in the hatchery.
- Reduce the smell and dust.



39. What are the benefits of good biosecurity practices in hatcheries?

Good biosecurity practices in hatcheries bring about the following benefits to hatchery owners, farmers and the community:

- Hatchability rate increased, dead embryos' reduced,
- Percent of chicks living past 1 week increased.
- Chicks hatched are healthy and of high quality.
- Improved environmental and working conditions for workers and less chance of workers getting sick.



40. What are the main bio-security principles?

There are three main bio-security principles:

1. Segregation and movement control of people and vehicles
2. Cleaning
3. Disinfection



41. Why do we have to implement the principle of segregation and movement control?

Segregation helps prevent disease agents from entering into poultry hatcheries and proper implementation of this principle will help prevent disease transmission.

In order to carry out segregation, we have to:

- Build and maintain a fence around the hatchery.
- Build a closed gate at the entrance to the hatchery.
- Set up movement regulations at the hatchery and ensure that these are respected.
- Conform to movement control regulations for workers, eggs, incubating and hatching equipment, tools, chicks and transport vehicles.
- Keep contacts from visitors, direct deliveries, guests and family members to a minimum – zero if practical.
- Keep cats, dogs and other animals out of the hatchery.
- Incorporate strict rodent and insect control programs.



42. Why do we have to implement the principle of cleaning?

Cleaning with brushes, brooms, water, soap and detergent helps remove dirt and organic material from the surfaces of tools, equipment, incubators, hatcheries, floors, walls and ceilings. Only after dirt is removed can disinfectants work efficiently.

Special attention should be made to tools, properly clean incubation and fumigation equipment and transport vehicles especially if they came from other farms, markets, traders or hatcheries.

Proper cleaning can remove up to 80% of potential disease pathogens. Prompt cleaning will prevent spread of the contamination throughout the hatchery.



43. Why do we have to implement the principle of disinfection?

Disinfection helps eliminate any remaining pathogens or disease agents after cleaning.

Disinfection is only effective after good cleaning. It is important to ensure the suitability of disinfectants, the correct dilution rate and the proper use. Make sure that contact time between disinfectants and surfaces that needs to be disinfected is at least 10 minutes.

It is advisable to rotate disinfectants every 4-6 months to prevent resistance and to keep attention on this important step.



44. Why do we have to separate incubation and hatching areas from people's living areas?

It is necessary to separate incubation and hatching areas with people's living area to avoid disease transmission to people, especially respiratory diseases. Dust, faeces, and feathers can contain pathogens including Salmonellosis, Colibacillosis and Avian influenza that can make people sick.

Movement of people other than hatchery personnel into and out of the hatchery compromises the principle of segregation and movement control.

Some fumigation and sanitation practices result in temporary conditions that are not appropriate for living areas.



45. Why do we have to separate incubation and hatching areas?

The incubation area is considered as the “clean area” while the hatching area is a “contaminated area”. In the hatching area, there can be a lot of waste material, dead chicks, dust, feathers, and body fluids. These create a good environment for pathogens to grow. If the incubation and hatching areas are not separated, contaminated materials from the hatching area may contaminate incubation area and negatively affect the development of the embryos. There are many airborne contaminants in the hatching area. We must be certain that the ventilation system does not move air from the hatching area to the incubation area.



46. Why do we have to separate incubators and hatchers?

If incubation and hatching takes place in one machine, there will be a very low rate of successful hatching because:

- Rotten eggs, broken eggs, eggshells in the machine will produce toxic gases such as H_2S that negatively impacts the embryo development.
- Temperature and humidity requirements differ between incubation and hatching periods and this will impact one on the other.
- Liquids, membranes, and rotten eggs in the hatching area create an ideal environment for pathogens to develop and if pathogens spread to incubating eggs, embryo development is at risk.



47. Can people bring pathogens into hatcheries?

People that have been in contact with unhealthy or diseased poultry or have visited live bird markets can bring pathogens to hatcheries on their vehicles, clothes, footwear, hands and other material they are carrying. Therefore, before entering hatcheries, vehicles should be disinfected and people should be requested to wash their hands, change footwear and clothing.



48. Why do we want to keep rodents out of hatcheries?

Rodents should be kept out of hatcheries because they can:

- Carry pathogens (plague, Salmonellosis, Colibacillosis...).
- Damage electric wires and incubator equipment.
- Eat eggs and chicks



49. Why do we always have to keep hatcheries clean?

Hatcheries must be kept clean in order to:

- Help embryos develop well.
- Produce healthy chicks.
- Minimize pathogen contamination of eggs and chicks.
- Minimize contamination of workers
- Maitain a health-working environment.



50. How should you arrange incubating and hatching areas?

The egg arrival area, incubation area, hatching area, and chick delivery area must be separated. They must be conceived in a way to be able one-directional movement from

egg arrival => incubation => hatching => chick delivery area
in order to avoid cross-contamination between areas.

This applies not only to egg, equipment and people movement but also to air movement.



51. What are some best management practices for the egg arrival area?

Egg delivery personnel should be allowed to enter the egg arrival area only. They should not be allowed to enter other areas of the hatchery.

The egg arrival area must be swept, cleaned and washed after all daily activities are finished. Do not sweep when eggs are present or contamination on the floor will be raised into the air and settle on the eggs. Also care when spraying should avoid getting water splashed from the floor to the eggs.

This area also needs to be disinfected with proper disinfectants twice a week.



52. How should an incubation area be cleaned and disinfected ?

- The floors of the incubation area must be swept daily, cleaned and disinfected weekly.
- The walls, ceiling and the humidifying trays must be cleaned and disinfected weekly.
- Blankets, mats or materials used to cover eggs must be fumigated or placed in sunlight for at least 4 hours once a week and must be washed with detergent at least once a month (if it is a manual hatchery).
- The tops and sides of the exterior of the incubator should be cleaned and disinfected frequently – every 2-3 weeks as appropriate.
- Footbaths should be checked daily to see that they have proper levels of clean disinfectant.



53. How should a hatching area be cleaned and disinfected ?

After each hatching, all chicks must be brought out of the hatching area. Use a broom to sweep and collect all solid waste from the hatchers, hatching area (eggshells, feathers, rotten eggs, dead chicks etc.), the tops of the hatchers and other exterior surfaces for disposal.

Then use water and detergent to remove any remaining dirt from the hatching area, hatchers, tools and equipment kept in this area.

When the hatchers and hatching area are dry, spray disinfectant on the whole hatching area and fumigate/disinfect hatchers and the equipment before placing the next batch of eggs into the hatchers.



54. Why should the hatching shelves be raised above the ground?

In hatcheries in the Central and Southern Regions of Viet Nam, hatching shelves are often used instead of hatching machines. The shelves should be raised above the ground to allow easy cleaning and washing of the floor, and to avoid dust accumulating and creating a favorable environment for mold and bacteria to grow, to avoid contact with the ground will cause the eggs to lose too much heat to the ground surface, reducing successful hatch rate.



Photo: Hatching shelves in a hatchery house are raised to avoid keeping eggs on the floor



55. How should a chick delivery area be cleaned and disinfected?

After all the chicks are sold, use a broom to sweep and collect all waste for disposal. Use water and detergents to remove remaining dirt in the chick delivery area.

Spray disinfectants over all surfaces that have been cleaned. Egg trays, containers for chicks and other tools must be washed with water and detergents before they are soaked in disinfectants, sprayed with disinfectants, or exposed under the sun.



56. What are the benefits of disinfection?

Disinfection eliminates any remaining bacteria (or disease causing agents) after cleaning. Disinfection is only effective when all dirt has been removed during the cleaning process because:

- Disinfectants are only effective on clean surfaces
- Many disinfectants are neutralized upon contacts with organic substances such as liquids, membranes, feathers, egg shells, etc.

Some disinfectant are also affected by minerals in the water, water hardness and pH.



57. What leads to disinfection failure?

- Disinfection would be failure if cleaning has not been done properly before disinfecting: dirt and organic matters (feces, waste, litter, broken eggs, dust, soil, etc.) remain on the surfaces and the disinfectant cannot act properly.
- Disinfection would be failure if using an unsuitable disinfectant, mixing an incorrect dilution of disinfectant, or inappropriate disinfectant application.
- Disinfection would be failure if using poor quality water (e.g. hard water, or water with a high level of iron, manganese, dirt or bacteria , or a pH below 8 for Quaternary Ammonia compounds,). A simple water filtration system with sand and activated carbon can help improve the water quality.



Photo: A simple water filtration system



58. What are the recommended egg cleaning and disinfection methods?

- Dry methods are more popular including fumigation with Formaldehyde or Ozone gas and UV light exposure. Of these, fumigation with Formaldehyde gas is the most popular and achieves good disinfection. Scraping or cleaning with sandpaper is not recommended, as it will actually increase contamination risks.
- In addition, washing and spraying using disinfectants can also be used. Be sure to follow egg washing-temperature guidelines and use approved egg washing compounds. Improper washing will actually increase egg contamination resulting in more exploding and unhatched eggs.



59. When is the best time to disinfect eggs?

When eggs are laid, they are wet and warm. The sudden reduction of temperature between the inside of the laying hen and the ambient temperature makes them more susceptible to contamination with bacteria and mould in the nest and environment. Thus, disinfection of fertile eggs must be done as soon as possible after collection to help reduce egg contamination levels.



60. What should be noted when eggs are fumigated?

1. Do not fumigate eggs when the eggshells are still wet because disinfectants can be absorbed into the eggs leading to dead embryos.
2. Do not fumigate eggs during the first 96 hours (4 days) of embryo development.
3. Do not fumigate eggs when chicks begin to pip out.



61. What should be noted if eggs are disinfected by washing or spraying

If eggs will be disinfected by washing or spraying disinfectants, the followings should be noted:

- Only use disinfectants approved for disinfecting eggs. These disinfectants do not react with the mucous membrane of the egg or stick to the eggshells (which may affect water and air exchange of the embryo).
- Always prepare the disinfectant concentration carefully according to the manufacturer's instructions.
- Disinfectant solution must be warmer than the eggs. This is very important. If egg temperature decreases during the soaking or washing process, contamination will increase rather than decrease.
- If eggs are washed and soaked, ensure the proper concentration of disinfectant mixture is used by making the disinfectant mixture with fresh disinfectant according to the manufacture's instructions.
- Dirty eggs need cleaning before disinfection.
- Be sure to change the disinfection solution frequently if soaking eggs as trying to disinfect dirty eggs will result in the disinfecting solution becoming overwhelmed by organic matter and will lead to an increase in comtamination rather than disinfection.



62. How should detergents and soap in hatcheries be used?

Detergents and soap are chemicals used for wet cleaning of surfaces to remove dirt, soil and organic matter. They are low-cost products but they can help eliminate 80% of contaminants. They provide an essential step in the cleaning and disinfection process. Disinfection can not occur if the surfaces are not cleaned first.



63. How should Ammonium Quaternary Compound (Quats) disinfectants be used in hatcheries?

These types of disinfectants are the number one choice for hatcheries. They have detergent and disinfectant properties that work well on cleaned and sealed concrete floors, as well as on other non-rusty, non-porous surfaces. They are relatively low cost and safe-to-use products. This only applies if they are used in the proper concentration due to their relatively low toxicity and irritation. Water pH should not be below 8 for maximum efficacy.



64. How should Phenolic disinfectants be used in hatcheries?

Phenolic disinfectants are specifically formulated to be used as a final treatment to kill a broad spectrum of bacteria, fungi and viruses known to be pathogenic to poultry. They also stop viral and bacterial growth when applied in the proper concentration. They have a good residual action and are helpful in disinfecting porous surfaces like wood.



65. How should Iodophors disinfectants be used in hatcheries?

Iodophor disinfectants are often used in rotation with Phenolics or Ammonium Quaternary Compounds Disinfectants to prevent resistance in micro-organisms. They work well on pre-cleaned surfaces and can be used in hard water. They have an activity indicator - the solution is no longer good when it loses its yellow color. They are inactivated by high organic levels and have no residual action. They tend to stain surfaces yellow-brownish which limit their use. They are primarily used at hatcheries as a foot-bath disinfectant and for disinfection of baskets, trays and other equipment.



66. How should Glutheraldehyde disinfectants be used in hatcheries?

Glutheraldehyde disinfectants are very effective against a wide range of pathogens and can be cost effective. However, being relatively toxic compounds, protective gear (PPE) is required for handling and application. These disinfectants are most toxic to the environment and using exact recommended concentration is essential to prevent toxicity.



67. How to use a combination of Glutheraldehyde and Ammonium Quaternary disinfectants in hatcheries?

A combination of Glutheraldehyde and Ammonium Quaternary disinfectants are effective against a wide range of pathogens. This combination is often used to clean and treat solid waste containers, solid waste stations and delivery areas.



68. What protective clothing should we wear when using disinfectants, in order to ensure our safety?

Most cleaning and disinfecting agents are poisonous and carry special warnings or residue precautions.. Therefore, upon using these chemicals, full personal protective equipment is recommended including:

- protective clothing including long pants and long-sleeved shirts,
- rubber boots,
- a respirator or mask,
- goggles or protective eye wear,
- a hat,
- rubber gloves

🗑️ Note: Remember to wash your hands, boots, and protective eye wear right after handling disinfectant chemicals.

Wash the rubber gloves if they are not disposable or throw them away.

Change out of chemical exposed clothes and wash them.

Dispose of excess disinfectant properly.

Carefully clean and rinse sprayers and other equipment used to mix and spray disinfectant.



69. How can we ensure that spraying disinfectants in the hatchery is effective?

- Remove all dirt during the cleaning process, before disinfection.
- Use proper disinfectants at the proper concentration.
- Prepare the disinfectant solution according to the manufacturer's instructions.
- Apply the correct volume of the disinfectant solution to coverage the entire surface of whatever is being disinfected.
- Ensure an effective contact time of at least 10 minutes for all types of disinfectants.
- Practice the concept of segregation and separation – do not re-introduce contaminants immediately after disinfection.



70. How to calculate the correct amount of disinfectant?

Using the proper concentration of disinfectant and appropriate contact time are important to ensure that the sprayed disinfectant is effective. Therefore, correctly calculating the amount of disinfectant and water required for the spraying solution is extremely important. For calculating this, you need to know:

- 1) The Area to be disinfected - in square meters (m²);
- 2) The quantity of mixed solution required
(Based on an average of 300ml (0.3 liters) per 1m²);
- 3) The amount of disinfectant required is calculated according to:
 - a) the correct percentage (%) or dilution rate (how much disinfectant and how much water)
 - b) the recommended concentration in the manufacturer's information sheet attached to the disinfectant container

How to calculate the correct amount of disinfectant:

STEP 1: Calculate the total area to be sprayed including all walls, floor, ceiling (m²), and equipment.

- **Calculate the floor area**

How long is the floor in meters (m) x How wide is the floor in meters (m) = floor area in m²

- **Calculate the room size including all walls, floor and ceiling**

Floor area x 2.5 = total room area to be sprayed in m² + any extra for equipment = total area to be sprayed

STEP 2: Calculate the quantity of mixed solution required

Quantity of mixed solution required (liters) = total area to be sprayed x 0.3

STEP 3: Calculate the amount of the disinfectant required according to the correct dilution rate (%) recommended by the manufacturer (how much disinfectant and how much water)



71. An example of calculating the correct amount of disinfectant

Excercise: How much disinfectant powder is required for spraying a hatchery that is 10m long and 4m wide knowing that the correct dilution rate of the disinfectant is 1% and the correct volume of the disinfection solution is 300 ml (0.3 liter)/ 1 m².

Calculation:

STEP 1: Calculate the total area to be sprayed

- Calculate the floor area = 10m x 4m = 40 m²
- Calculate the room (including all walls, floor and ceiling) = 40 m² x 2.5 = 100 m²

STEP 2: Calculate the quantity of the mixed solution required = 100 m² x 0.3liter/ m² = 30 liters

STEP 3: Calculate the amount of disinfectant powder required

Dilution rate of 1% means 1g disinfectant powder to be mixed with 100 ml water or 10g disinfectant powder to be mixed in 1 liter of water

Thus, the amount of the disinfectant required = ***30 liters of required mixed solution x 10g = 300 grams of disinfectant powder.***



72. What are the principles for the correct spraying of disinfectants?

- 1) Spray in the same direction of the wind,
- 2) Spray downwards on the wall,
- 3) Spray from the inside to outside of the ceiling and floor,
- 4) Spray starting at farthest point from the exterior door and end spraying at the exterior door.
- 5) Spray in a zigzag shape, so that the next spray overlaps with a part of the previous area sprayed and the disinfectants is applied to the entire surface that needs to be disinfected.



73. What to pay attention to when spraying disinfectants in hatcheries

When spraying disinfectants in hatcheries, pay attention to the following:

- Wear all necessary personal protective clothing.
- Read the labels on the disinfectant container carefully.
- Use a balance, measurement cup or syringe to ensure correct measurement and prepare the disinfectant solution in the correct concentration according to instructions recommended by the manufacturer.
- Apply the disinfectant solution in the correct volume and ensure that the contact time between the solution and the disinfected surface is at least 10 minutes.
- Avoid contaminating the eggs during the sweeping and spraying process – best done with no eggs or chicks in the area.
- Also best done when most workers are gone.
- It is better to spray disinfectants in the early morning or late afternoon to avoid the hot time of the day.



74. How should Formalin with Potassium permanganate be used for fumigation? What should we note before using it?

Formaldehyde gas has been used in poultry hatcheries as an effective disinfectant for fumigation of eggs and hatchery equipment to reduce contaminant levels caused by bacteria, viruses and moulds.

Mixing Formalin with Potassium permanganate will produce Formaldehyde gas which fumigates eggs, hatchery tools, and equipment in an air-tight fumigation cabinet. Each cubic metre (m³) of the fumigation cabinet needs 40 ml of Formalin and 20 grams of Potassium permanganate.

When using the chemicals, please note:

- Both Formalin and Formaldehyde gas are VERY toxic. Thus there is a need to wear full protective equipment (see required PPE on question No 67) and be cautious when handling them.
- Always pour Formalin into Potassium permanganate to avoid accidents; never do the reverse.
- Close the chamber and leave it closed for extended period.
- Leave the room if you can smell the formaldehyde gas.
- The reaction creates heat – use in small vessels that will not melt or burn. Do not use large quantities in large containers.
- Liquid Formalin must be stored in an air tight and leak proof container in a dry, well ventilated area. It should be protected from extreme heat or fire, and away from other chemicals.



75. What are the requirements for a fumigation cabinet?

The fumigation cabinet must have an air tight seal to prevent any gas from escaping during fumigation and should be constructed with the following in mind:

- Cabinets can be made of bricks and cement with tile flooring inside, or made of an inox frame and inox or galvanized metal sheets.
- The door can be made of inox or galvanized metal sheets with rubber seals on the inside to ensure that the cabinet is sufficiently air tight to avoid gas escaping during fumigation.
- The cabinet must be equipped with an earthenware (or enamelware) bowl for potassium permanganate and a funnel for pouring formalin (37.5%) into the bowl from the outside. The bowl must have a capacity of at least 10 times the volume of the total chemicals to be added.
- If the cabinet volume is more than 1m³, the cabinet should be equipped with an air circulation fan so the fumigation gas can evenly circulate in the cabinet.
- The cabinet must be equipped with an extraction fan to ensure total venting of formaldehyde gas before the cabinet is opened.
- Formaldehyde gas must be removed using an external exhaust pipe with a height reaching 3-4 meters above the top of the house roof to prevent people from being exposed to vented gas. An exhaust valve must be inserted to the exhaust pipe and a venting flap should be attached to the side of the cabinet.

See the photos and diagram in the next page for further details.

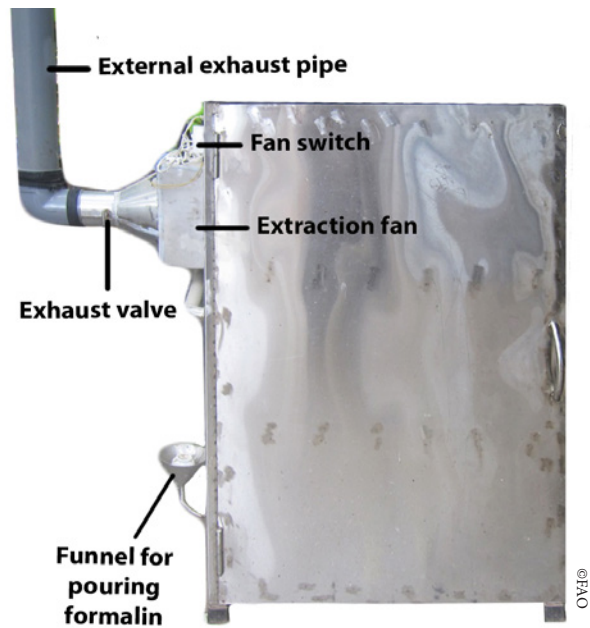

The outside of a fumigation cabinet (volume 1m³)

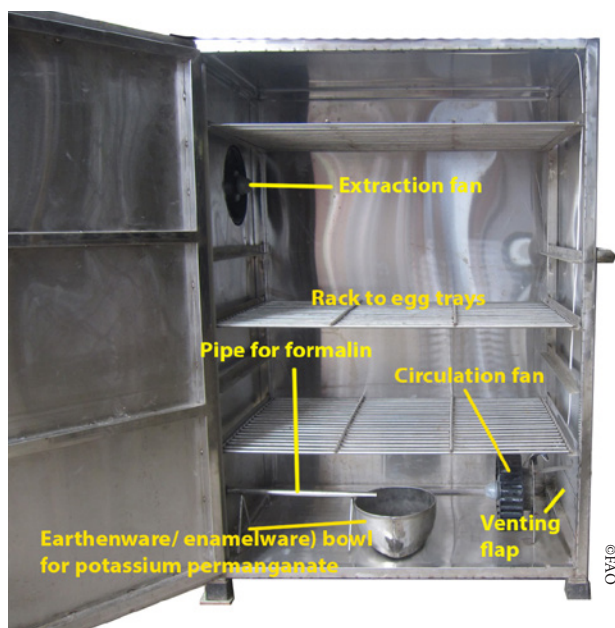

The inside of the fumigation cabinet

THIẾT KẾ TỦ XÔNG TRƯỞNG INOX 1m3 - TỶ LỆ 1/25
INOX FUMIGATION CABINET DESIGN 1m3 - SCALE: 1/25

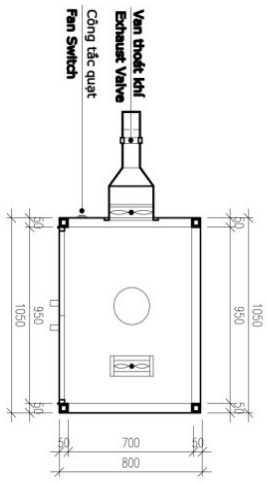

MẶT BẰNG
PLAN

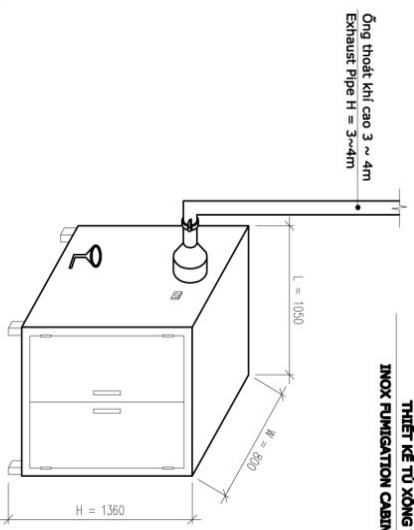

MẶT CẢNH
PERSPECTIVE VIEW

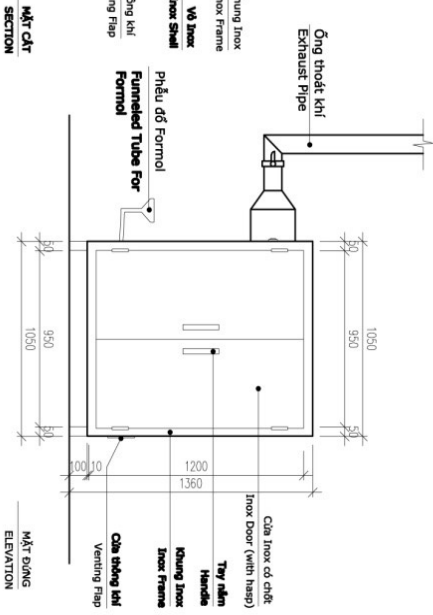
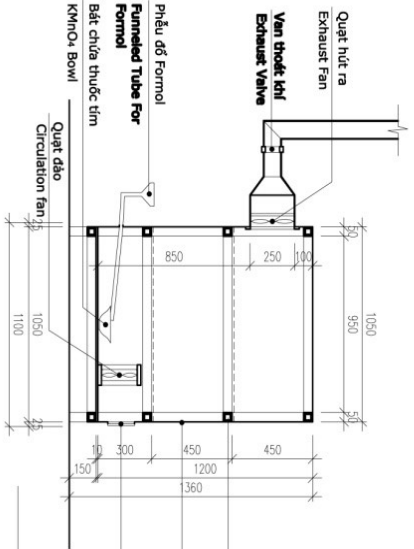

©FAO

Fumigation cabinet design (volume 1m³)



76. What are the proper egg fumigation procedures when using formalin and potassium permanganate?

The steps required for proper egg fumigation using formalin and potassium permanganate in a 1 m³ fumigation cabinet are:

1. Put on proper personal protective equipment: respirator/mask, goggles, rubber gloves, and protective clothing;
2. Place egg trays on the shelves inside the fumigation cabinet;
3. Place 20g of Potassium permanganate into ceramic or enamel metal bowl at the bottom of the fumigation cabinet, below the funnel. The bowl should have a capacity of at least 600 ml;
4. Close the cabinet and hang a warning sign on the fumigation cabinet door stating: “Do not open the door, the cabinet is in operation”;
5. Measure 40ml of formalin and pour into the funnel;
6. Turn on the circulation fan;
7. Let the cabinet operate for 20 minutes;
8. Turn on the exhaust valve and fan, open the venting flap, and let venting take place for 20 minutes; and
9. Open the cabinet door, remove the warning sign and move the eggs into a clean storage area inside the hatchery.



77. Are the chemicals used in hatcheries dangerous for humans?

Currently, there are many chemicals used in livestock production and hatcheries. It should be noted that all chemical disinfectants can be harmful and toxic to humans if they are not used properly.

Disinfectants will be more dangerous if they are used under hot sunlight as at this time, chemicals will be absorbed more rapidly and can easily cause poisoning for users.

People can potentially be harmed by contacting or inhaling the chemicals or fumes. As well, some chemicals are highly flammable. Proper precautions should be taken to prevent exposure and work in properly ventilated room.



78. What is it important to properly clean and disinfect the hatchery?

Improper disinfection results in:

- Bacteria and other potential pathogens grow and put the production and health of the chicks and hatchery workers at risk.
- If cleaning is not done properly, using disinfectants is a waste of time, money, and labor costs.
- Unnecessary use of disinfectant also contributes to an additional input into the environment, and one that may damage the health of the environment and ecosystem.



79. How should eggshells and dead chicks be disposed?

- Eggshells and dead chicks must be transported to public or private designated areas far from hatcheries.
- Disposal of egg shells and dead chicks should be carried out by burning, deep burial or composting.
- This should be done in a place where no poultry are being raised or reared.



80. What production data the hatchery need to record?

The hatchery need to record the following production data:

- Origin of hatching eggs (from what parent flock, age of the parent flock etc.)
- Number of setting eggs
- Egg quality (clean level, eggshell quality etc.)
- Results of candlings (number of non-embryo, dead-embryo eggs etc.)
- Hatchability
- Number of the 1st grade chicks hatched
- Problems occurred during egg incubation and hatching
- Cleaning and disinfection plan

Here a recording table for reference

Date	Egg origin	No. of setting eggs	Number of culling eggs (1st candling)		No. of culling eggs (2nd candling)	No. of un-hatched eggs	No. of 1st grade chicks	Note
			Non-embryo eggs	Dead-embryo eggs				

ECTAD Emergency Centre
for Transboundary Animal Diseases

Viet Nam

ISBN 978-92-5-109813-4



9 789251 098134

I7492EN/1/06.17