

LIFTABLE PROPULSION SYSTEM - BOB DRIVE

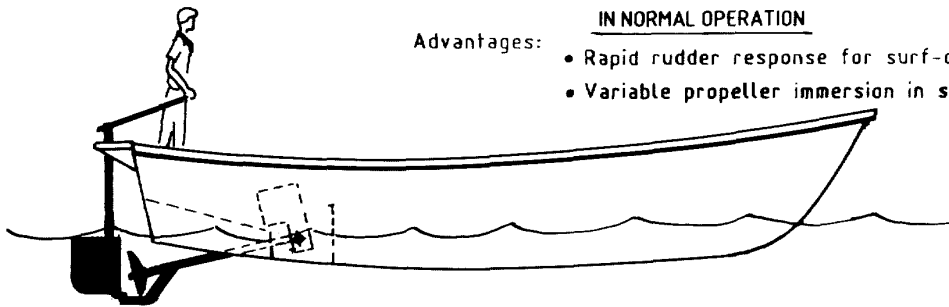

IN NORMAL OPERATION

Advantages:

- Rapid rudder response for surf-crossing
- Variable propeller immersion in shallow areas.

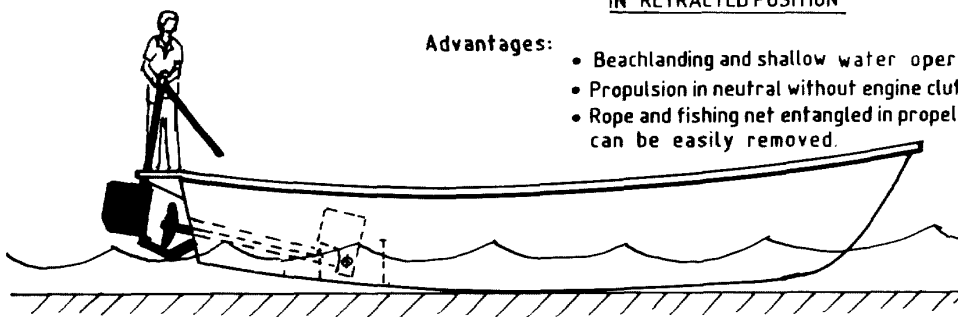

IN RETRACTED POSITION

Advantages:

- Beachlanding and shallow water operation
- Propulsion in neutral without engine clutch
- Rope and fishing net entangled in propeller can be easily removed.

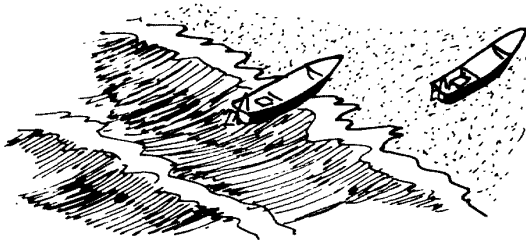

BEACHLANDING



RIVER OUTLET WITH SHALLOW WATER

CONVENTIONAL ENGINE INSTALLATION

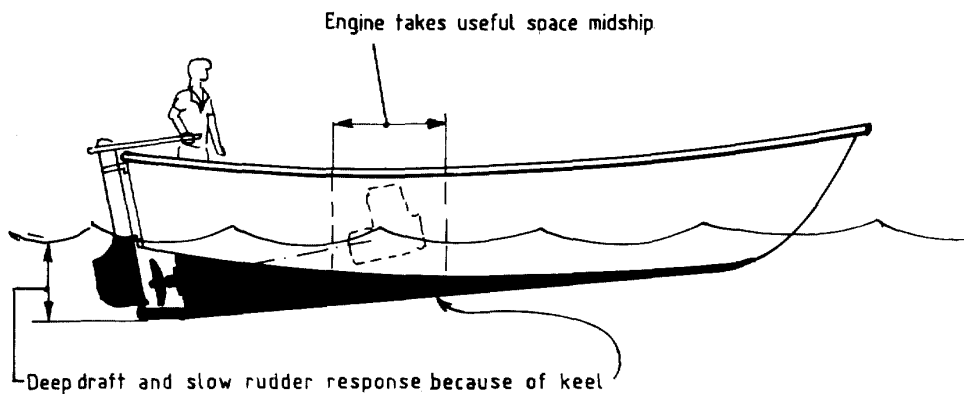

Engine takes useful space midship

Deep draft and slow rudder response because of keel

BOB DRIVE

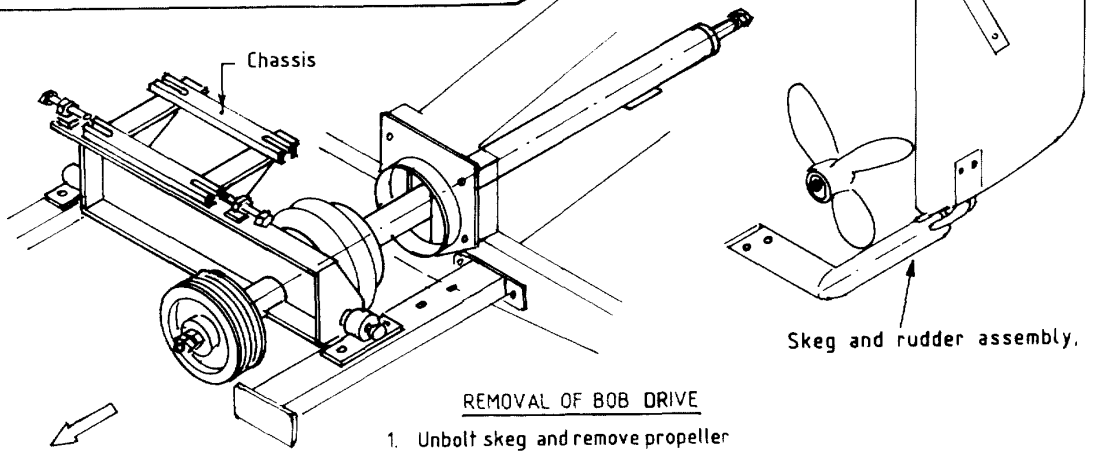
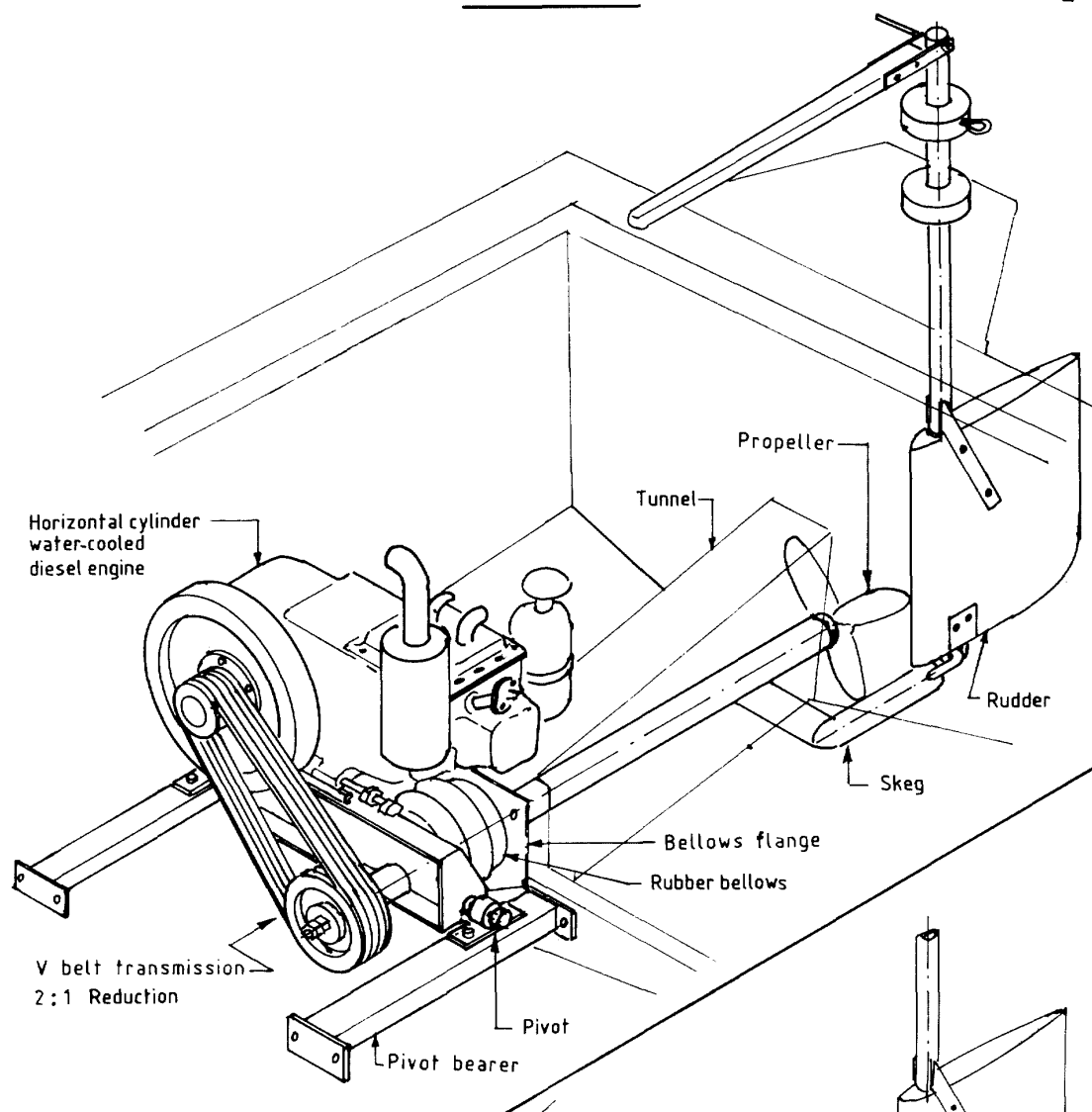

REMOVAL OF BOB DRIVE

1. Unbolt skeg and remove propeller
2. Remove engine
3. Remove pivot bolts
4. Loosen bellows hose clips
5. Slide BOB Drive forward and up

Forward

DIESEL ENGINES FOR THE BOB DRIVE

3

WATER-COOLED

Hopper cooling: Preferred for installation in boats, because of low cost.

Radiator cooling: Can be used after modifications

AIR-COOLED

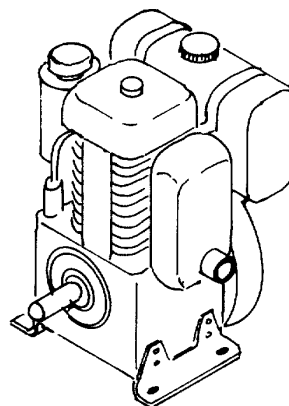
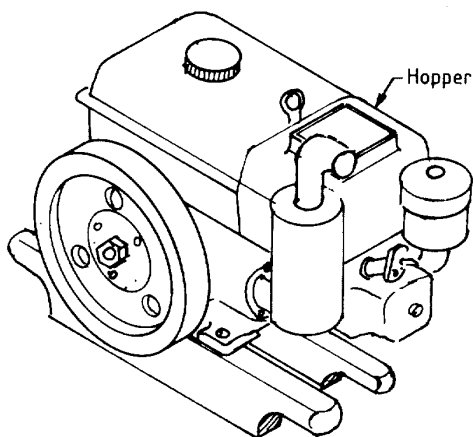

Multipurpose engines used for pumps, generators, power tillers and tractors have the advantage of low price and availability of spare parts

The engines are single cylinder and available in the range of 4 hp to 15 hp.

Kerosene engines can also be used. They are cheaper to buy, but have more operating problems because of electric ignition.

The selection of air-cooled or water-cooled engine will depend on what is available locally. Air-cooled engines are simpler, but the installation must permit a free flow of air. Single cylinder engines have strong vibration. In some engines this is compensated for by a counter rotating balancer.

SELECTION OF ENGINE POWER

Engine power is mainly dependent on the displacement (weight of boat including the normal load.)

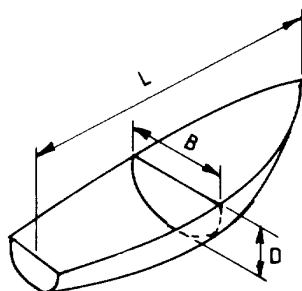

If the displacement is not known it can be estimated by using the CUBIC NUMBER = $L \times B \times D$

Measurements are in metres.

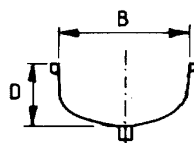

Table 1. Engine power

Cubic number $L \times B \times D (m^3)$	Displacement kg	Installed continuous hp.
5	500	3
10	1000	6
15	1500	9
20	2000	12
25	2500	15

Note ; Engine power (hp) is for continuous output.

The speed obtained under normal wave conditions with the installed engine power shown to the left and assuming that the engine is operated at 3/4 power, will mainly be dependent on the length of the boat (L)

Length (L) metre	Speed in knots
6	5.2
7	5.6
8	6.0
9	6.3
10	6.7

THREE WAYS OF MOUNTING THE ENGINE

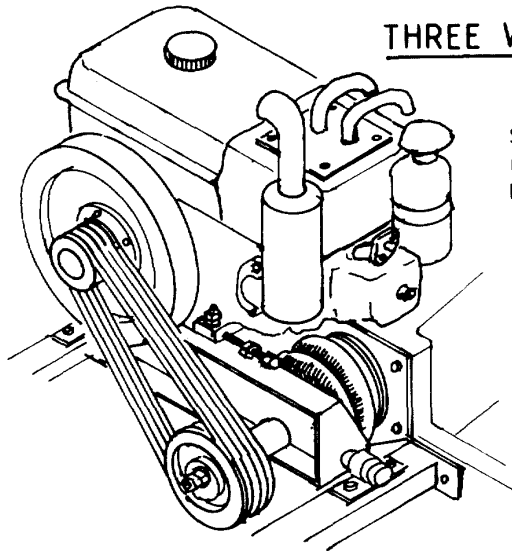

Side mounted engine is the best method. It gives more space for passage on one side and easy belt tensioning

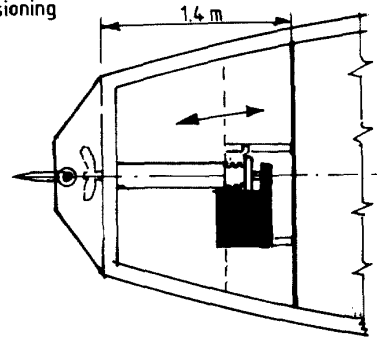

Side mounted engine

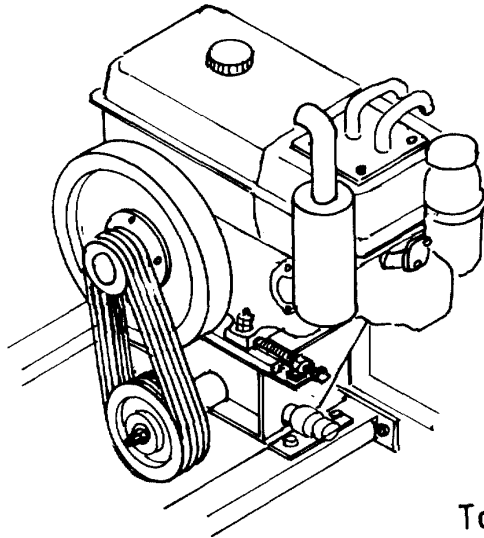

Top mounted engine is mainly used in narrow canoes

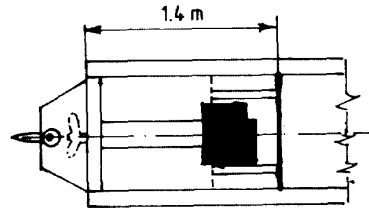

Top mounted engine

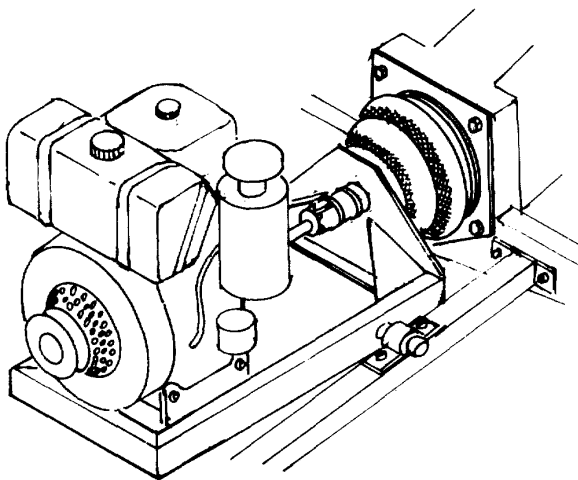

Forward mounted engine can be used when the engine has a reduction gear or a camshaft drive (2 : 1 reduction)
This installation requires more space in the boat and a bigger rubber bellows

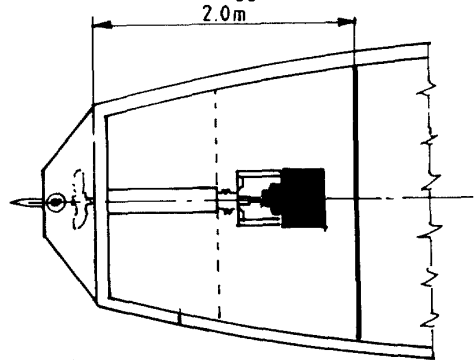

Forward mounted engine

SELECTION OF V-BELT TRANSMISSION.

The diameter of the V-belt pulley fixed to the propeller shaft is the same for all engines : D = 200 mm (8")

The diameter of the V-belt pulley fixed to the engine : A section belt D = 100 mm (4") Reduction ratio = 2 : 1
 B section belt D = 125 mm (5") Reduction ratio = 1.6 : 1

Table 2. V-belt transmission

V-belt section mm	Engine pulley Pitch diameter mm	ENGINE POWER Continuous hp	NUMBER OF BELTS	
			Engine RPM	
			2200	3000
A 		4	2 A	2 A
		5	2 A	2 A
		6	3 A	2 A
		7	3 A	3 A
		8	4 A	3 A
		9	4 A	3 A
B 		10	4 A	4 A
		11	3 B	4 A
		12	4 B	4 A
		13	4 B	4 B
		14	4 B	4 B

SELECTION OF PROPELLER

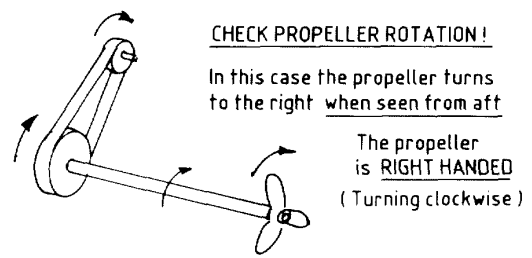
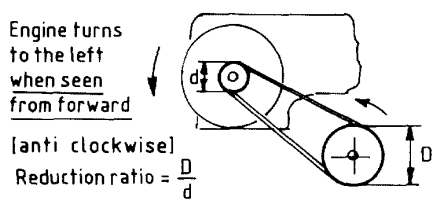

EXAMPLE

ENGINE : Horizontal cylinder engine turning left when seen from the flywheel end (power take off).
 ENGINE CONTINUOUS POWER : 9.0 hp at 2200 rpm.
 V-BELT TYPE : A section V-belt. Number of belts : 4 . Pulley diameter = 100 mm. (from Table 2) Reduction ratio = 2 : 1
 PROPELLER RPM : Engine rpm / 2 = 2200 / 2 = 1100 rpm.
 PROPELLER ROTATION: Right handed.
 PROPELLER : Diameter = 15 inch . Pitch = 10 inch . Three-bladed. Blade area ratio = 0.35 - 0.50. (From Table 3)

ENGINE CONTINUOUS POWER hp	Table 3. Propeller								
	The propeller dimensions are for a three-bladed propeller with blade area ratio: 0.35-0.50 and a boatspeed = 5.5- 6.5 knots								
	DIAMETER x PITCH (inches) versus PROPELLER RPM								
	1000	1100	1200	1300	1400	1500	1600	1700	1800
4	13 x 10 1/2	13 x 9 1/2	12 x 9	12 x 8 1/2	11 x 8	11 x 7 1/2	10 x 7	10 x 7	9 x 6 1/2
6	14 x 10 1/2	14 x 10	13 x 9 1/2	12 x 9	12 x 8 1/2	11 x 8	11 x 7 1/2	11 x 7	10 x 7
8	16 x 11	15 x 10	14 x 9 1/2	13 x 9	13 x 8 1/2	12 x 8 1/2	12 x 8	11 x 7 1/2	11 x 7
10	16 x 11	15 x 10 1/2	15 x 9 1/2	14 x 9 1/2	13 x 9	13 x 8 1/2	12 x 8	12 x 7 1/2	11 x 7 1/2
12	17 x 11 1/2	16 x 10 1/2	15 x 10	14 x 9 1/2	14 x 9	13 x 8 1/2	13 x 8	12 x 8	12 x 7 1/2
14	17 x 11 1/2	16 x 11	15 x 10 1/2	15 x 10	14 x 9 1/2	14 x 9	13 x 8 1/2	13 x 8	12 x 8

MEASURING PROPELLER DIAMETER AND PITCH

6

Propeller diameter and pitch are usually given in inches

The propeller diameter and pitch are often stamped on the propeller boss. In this case 13x9 means:
Propeller diameter = 13 inches
Propeller pitch = 9 inches

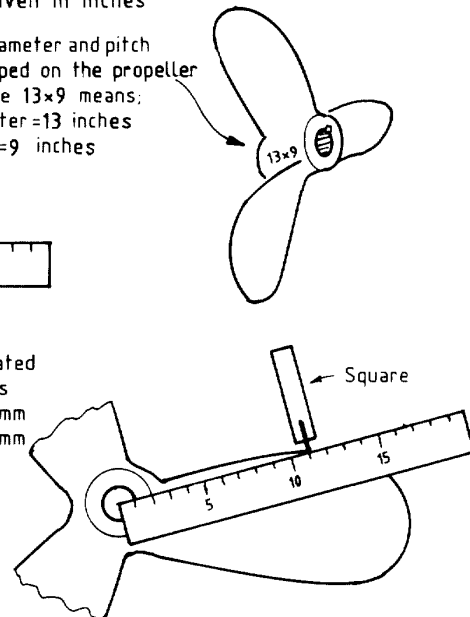
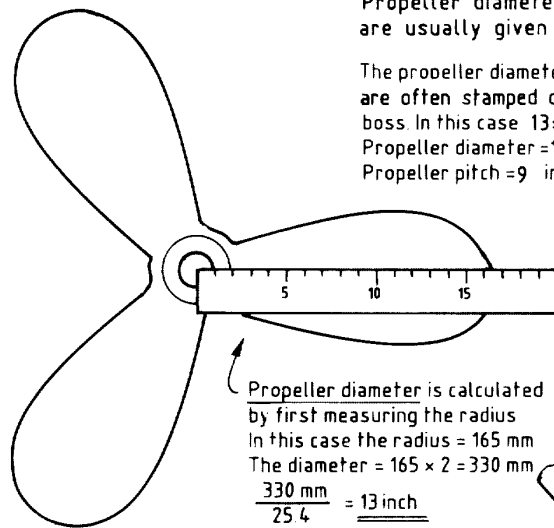

The propeller pitch is a measure for how far forward the propeller advances when making one turn.

The propeller pitch is measured as follows:

- 1) Measure the distance from the propeller centre to the widest part of the blade. Choose a round figure. In this case $A = 110$ mm
- 2) Make a mark at the edge of the propeller blade as shown. Use a square to get accurate marks on the lowest part of the blade as shown in top figure.

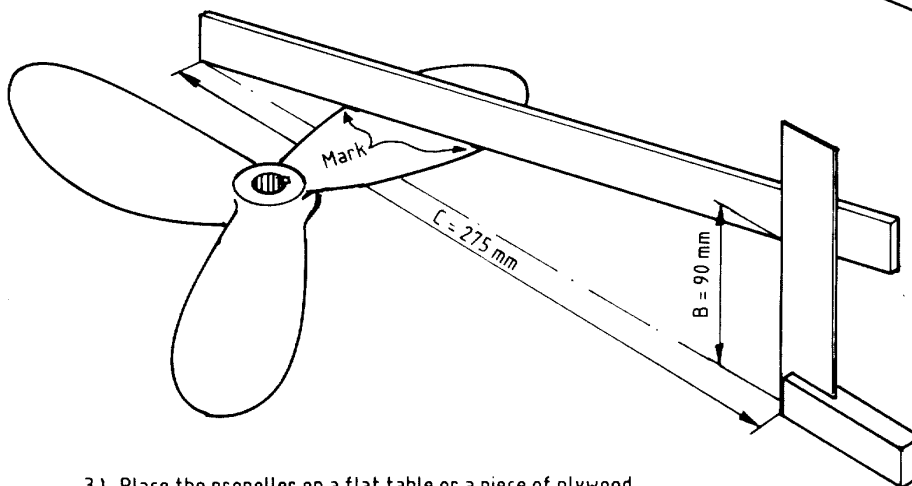
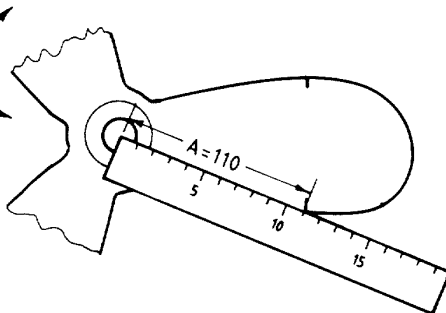

- 3) Place the propeller on a flat table or a piece of plywood with the propeller boss touching the table, not the blades.
- 4) Use a ruler or a straight edge minimum 30 cm long. Place it on top of the propeller blade alongside the two marks and with the corner of the ruler touching the table.
- 5) Measure distances B and C at any convenient point along the ruler
In this case $B = 90$ mm, $C = 275$ mm. Calculate the pitch:

$$\text{PITCH} = \frac{A \times B}{4 \times C} = \frac{110 \times 90}{4 \times 275} = \underline{9 \text{ inch}}$$

Note: A, B and C must be in mm.

BOB DRIVE COMPONENTS

These components are common for all engine mountings

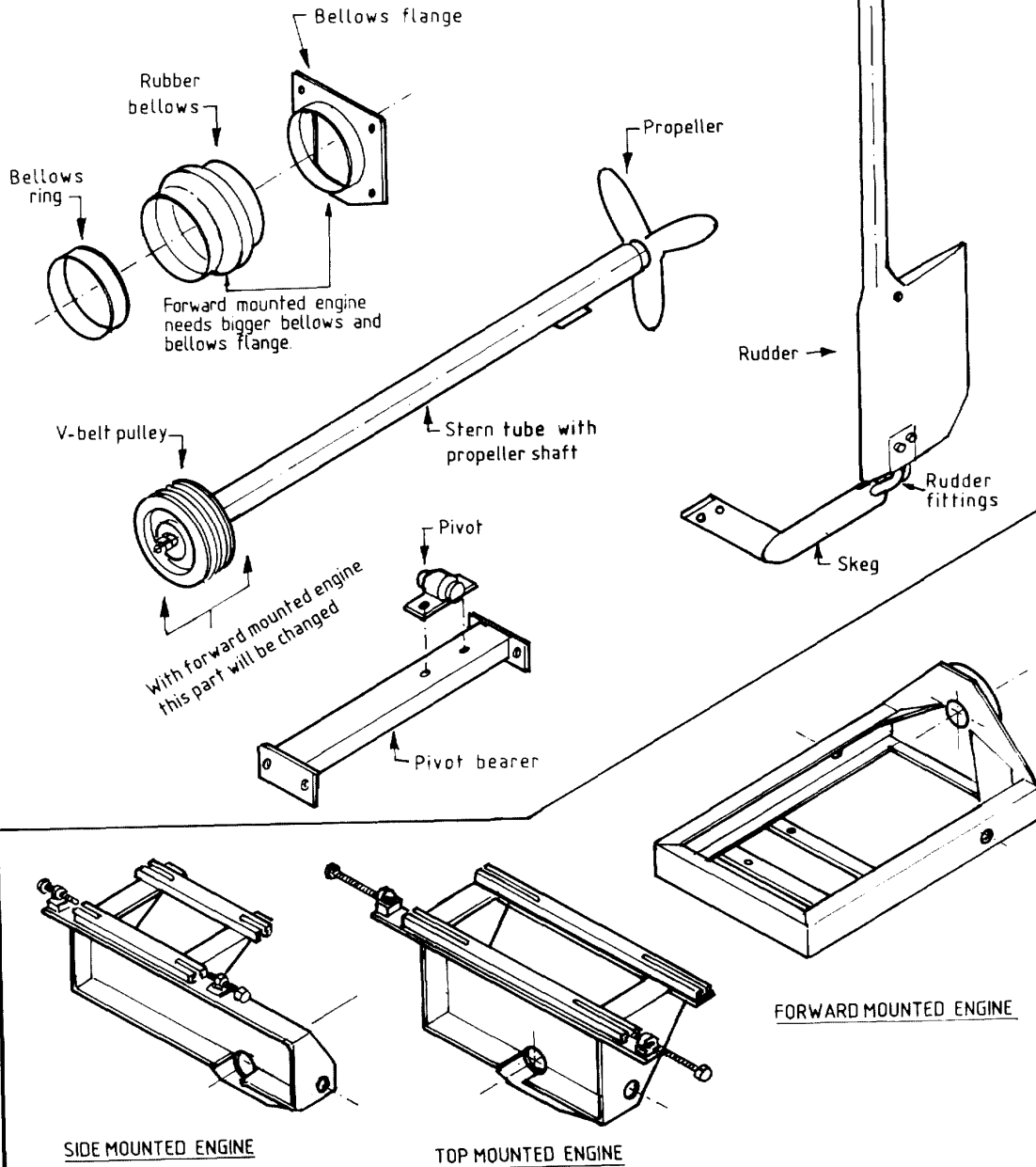

The chassis are different

MANUFACTURE OF BOB DRIVE COMPONENTS

Cut from 8 mm MS plate

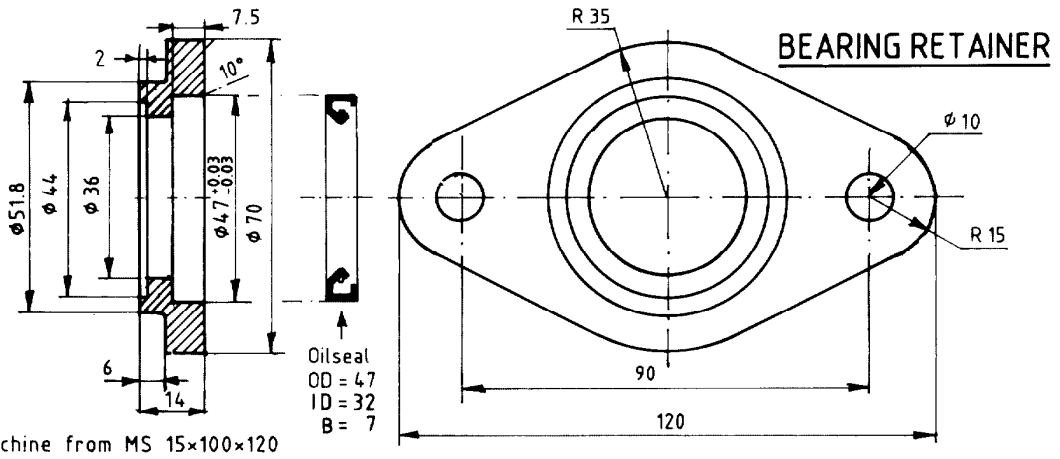
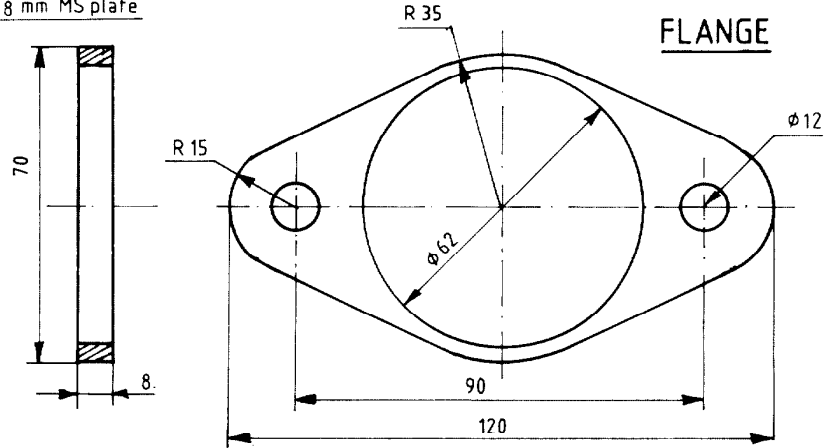

Machine from MS 15x100x120

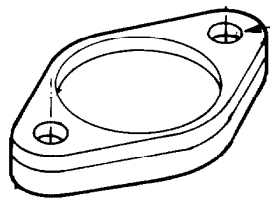

Drill holes $\phi 10$ in flange and bearing retainer at the same time. Then increase holes in flange to $\phi 12$.

Stern tube and skag tube are made from the same tube:
 OD = 60.3, ID = 47.7, Wall thickness = 6.3
 Other tubes can be used provided inside diameter ID = maximum 48

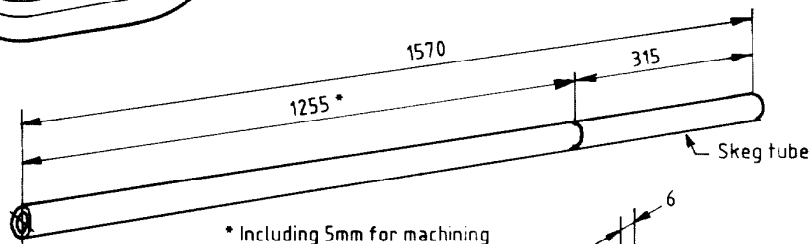

CUTTING STERN TUBE

WELDING ON FLANGE

The flange must be welded on the tube before machining the tube because of welding distortions

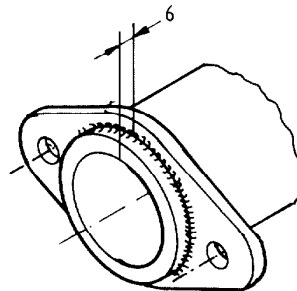

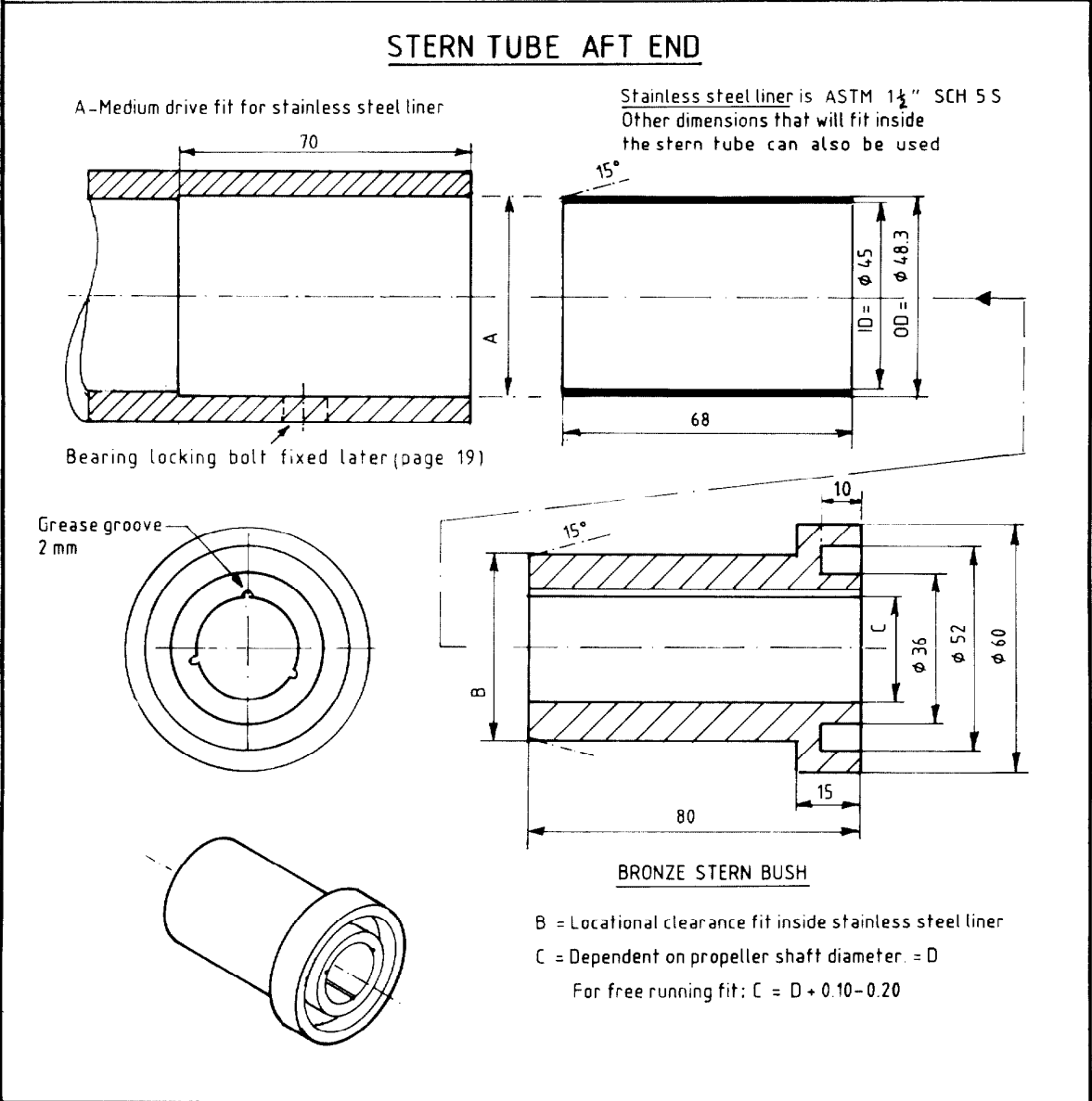
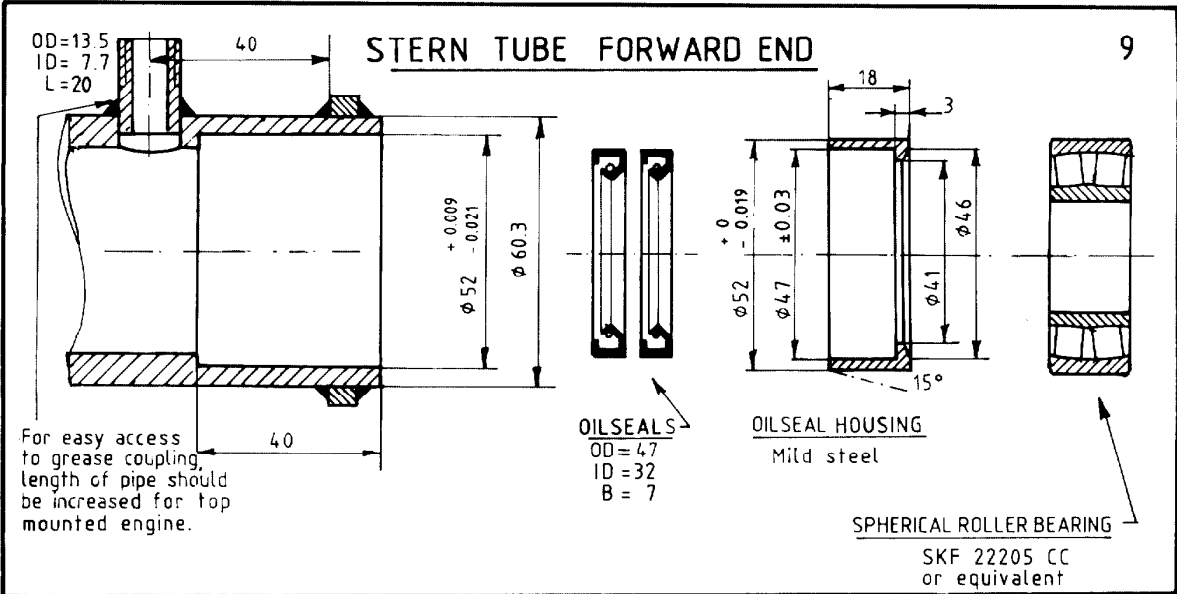

PROPELLER SHAFT

Material: Stainless steel 316



The diameter D of the propeller shaft is dependent on what is available. If 25 mm diameter shafts are slightly undersize, the roller bearing will not fit. Shafts of D = 25.4 mm (1") or 28 mm are acceptable.

FORWARD END

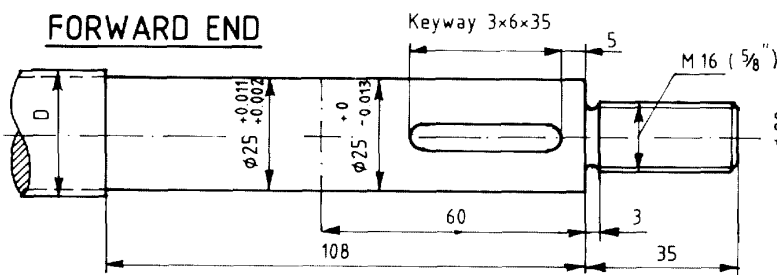

THRUST COLLAR

Stainless steel

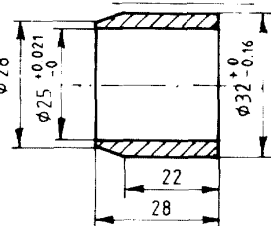

AFT END

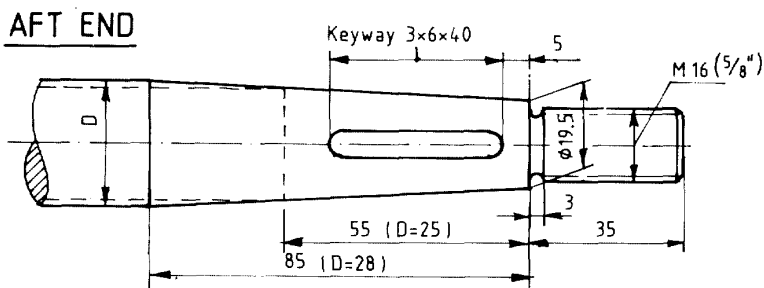

SPACER

Stainless steel

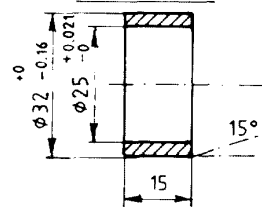

PROPELLER

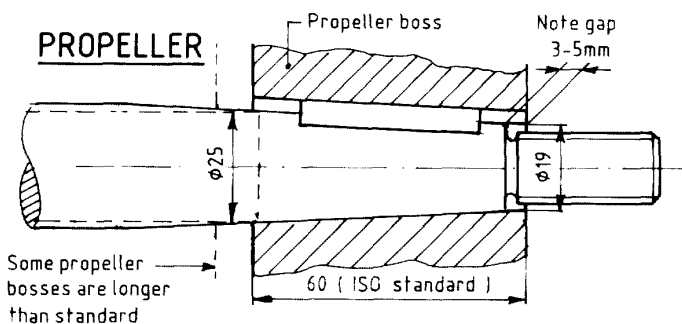

TAPER ON PROPELLER SHAFT
ISO STANDARD = 1 : 10

GREASE RETAINER

Material: Bronze

