

**Pathways to precision in
soil analysis: advancing
soil laboratories in Latin
America and the
Caribbean**

**Caminos hacia la
Precisión en el Análisis de
Suelos: avance de los
Laboratorios de Suelos
en América Latina y el
Caribe**

Reference Materials- *at the heart of reliable analysis*

Dr Michael Watts and Dr Christian
Hartman
BGS and IRD

 LATSOLAN
LATIN AMERICAN SOIL LABORATORY NETWORK

WORKSHOP
SANTIAGO - CHILLÁN | CHILE
8-11 APRIL 2024



Why are RMs important?

Quality management principles: **process approach** – a coherent system achieves **consistent and predictable results**

If the method provides **expected data for the RM** when all steps in the method sequence are used, there is confidence that it will provide **representative data for unknown samples**.

- Analysis of a well characterised sample provides the ultimate check of analytical method

Reference materials are important tools for the transfer of measurement accuracy between laboratories especially when it is important to ensure that chemical interferences and matrix effects are adequately addressed .

ISO/IEC 17025:2005

4. Management requirements

- 4.1. Organization
- 4.2. Management system
- 4.3. Document control
- 4.4. Review of requests, tenders, contracts
- 4.5. Subcontracting of tests
- 4.6. Purchasing services and supplies
- 4.7. Service to the customer
- 4.8. Complaints
- 4.9. Control of non-conforming work
- 4.10. Improvement
- 4.11. Corrective actions
- 4.12. Preventive actions
- 4.13. Control of quality records
- 4.14. Internal audits
- 4.15. Management review

5. Technical requirements

- 5.1. General
- 5.2. Personnel
- 5.3. Accommodation & environmental conditions
- 5.4. Test methods and validation
- 5.5. Equipment
- 5.6. Measurement traceability
- 5.7. Sampling
- 5.8. Handling of Test items
- 5.9. Assuring the quality of test results
- 5.10. Reporting the results

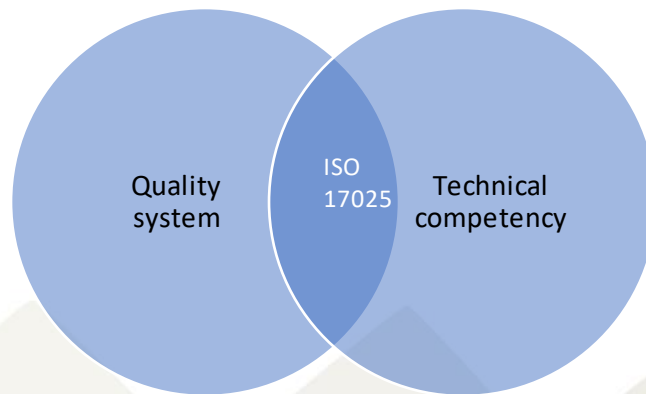

Technical requirements

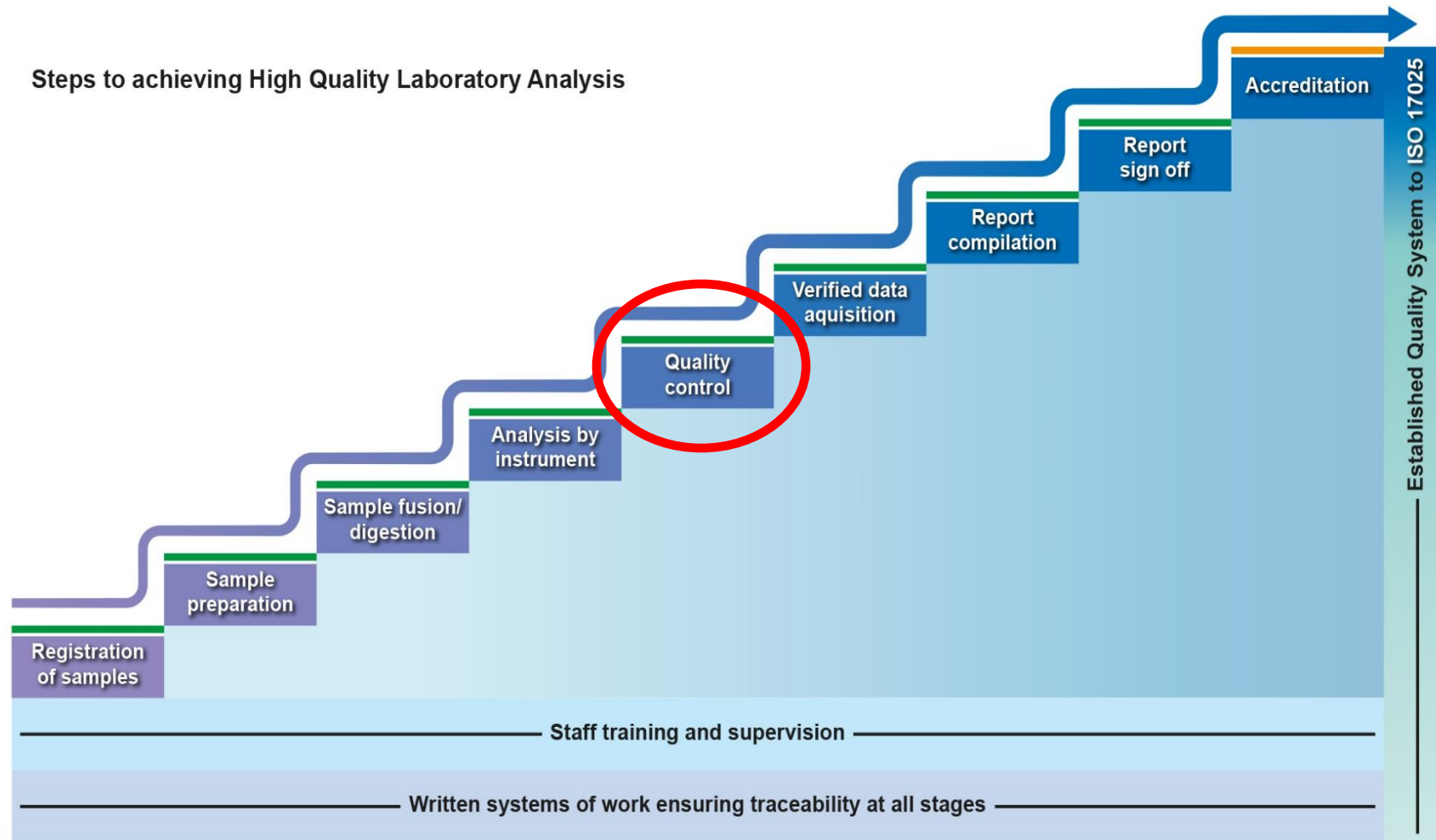



Pathways to precision in soil analysis: advancing soil laboratories in Latin America and the Caribbean

Caminos hacia la Precisión en el Análisis de Suelos: avance de los Laboratorios de Suelos en América Latina y el Caribe

WORKSHOP | SANTIAGO - CHILLÁN | CHILE

8-11 APRIL 2024





Pathways to precision in soil analysis: advancing soil laboratories in Latin America and the Caribbean

Caminos hacia la Precisión en el Análisis de Suelos: avance de los Laboratorios de Suelos en América Latina y el Caribe

WORKSHOP | SANTIAGO - CHILLÁN | CHILE

8-11 APRIL 2024



Particle size

Useable particle size:

- sieved to $<2\text{ mm}$ – widely accepted size fraction, ensuring removal of foreign objects from soil, e.g. grass, stones
- sieved to $<250\text{ }\mu\text{m}$ – identified as the particle size fraction that is most likely to be ingested from handling vegetables
- milled to $<53\text{ }\mu\text{m}$ – breakdown of soil particles allowing for increased sample homogeneity
- milled to $<32\text{ }\mu\text{m}$ – additional milling if solid sample analysis is undertaken where minimising particle size effects is important, e.g. aiding uptake during leaching or digestion

Sampling from the field

- Select location
 - make use of existing geochemical data and other prior information
- Identify method for sampling target material
 - e.g. topsoil, subsoil
- Identify a clean area of appropriate soil type
- Assess amount required
 - coarse/fine/representivity



Sampling and storage



Pathways to precision in soil analysis: advancing soil laboratories in Latin America and the Caribbean

Caminos hacia la Precisión en el Análisis de Suelos: avance de los Laboratorios de Suelos en América Latina y el Caribe

WORKSHOP | SANTIAGO - CHILLÁN | CHILE

8-11 APRIL 2024



Transportation

- Clear labelling
- Secure transit
- Protect package during transit
- Minimise amount - pre-preparation



Drying

- Stabilise the soil, prevents rotting
- Outside – slow
- Oven – overheating, briquetting
- Freeze assisted – can help if fine grained



Initial storage

- Appropriate container
- Sub-divide to prepare second source
- Stable environment to avoid deterioration



Initial sample division plan

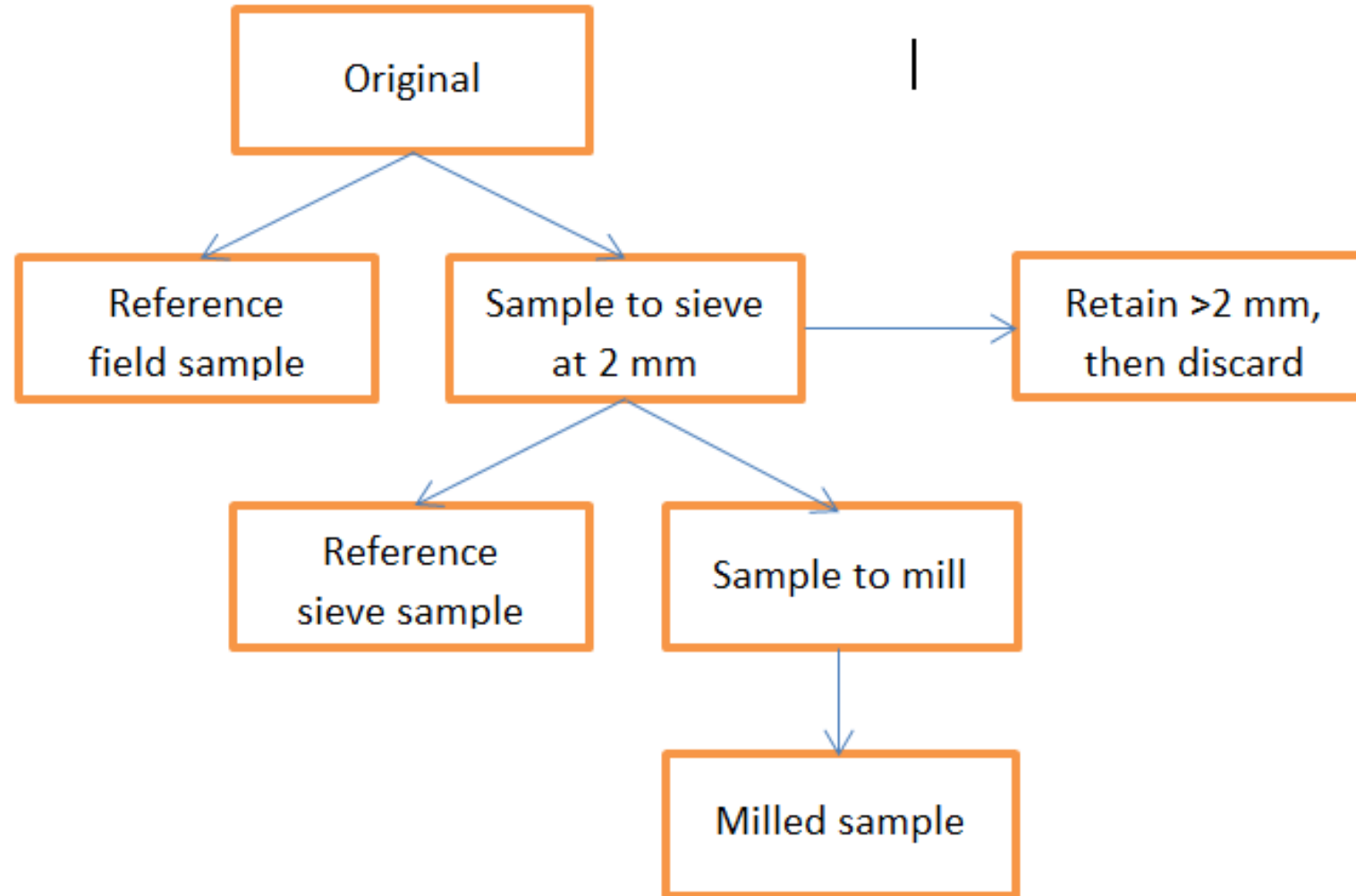

Disaggregation

- Lumps will not be uniformly distributed throughout material
- Material might generate a product that is not representative of the original material
- Disaggregation can reduce the chance of this happening
- Beware potential source of contamination



Sieving

- Required if certain particle size fractions are desired.
- Unwanted dilution and inhomogeneity
- <2 mm, <250 μm
- Removal of foreign objects from soil, e.g. aggregates, grass, stones.



Homogenising a bulk

- Prior operations inherently cause the material to partition.
- It is important to ensure that:
each split is representative of the whole; and
each portion taken is representative of the subsample used.





Pathways to precision in soil analysis: advancing soil laboratories in Latin America and the Caribbean

Caminos hacia la Precisión en el Análisis de Suelos: avance de los Laboratorios de Suelos en América Latina y el Caribe

WORKSHOP | SANTIAGO - CHILLÁN | CHILE

8-11 APRIL 2024





Pathways to precision in soil analysis: advancing soil laboratories in Latin America and the Caribbean

Caminos hacia la Precisión en el Análisis de Suelos: avance de los Laboratorios de Suelos en América Latina y el Caribe

WORKSHOP | SANTIAGO - CHILLÁN | CHILE

8-11 APRIL 2024



Nugget effect

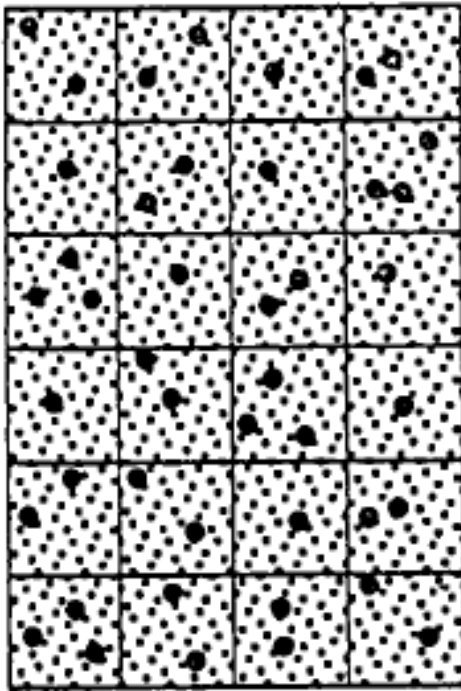

(a)

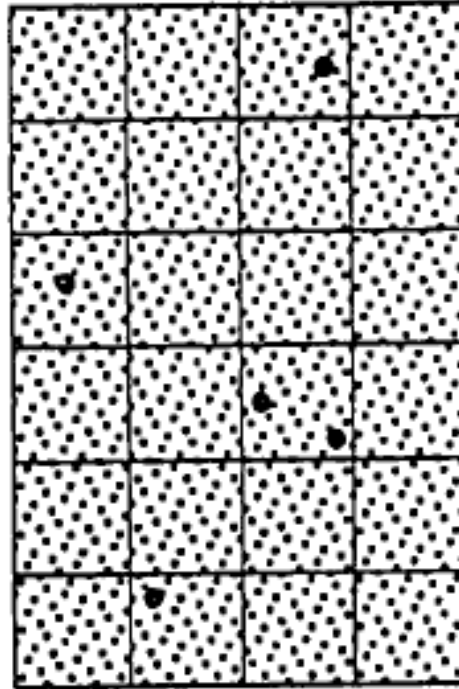

(b)

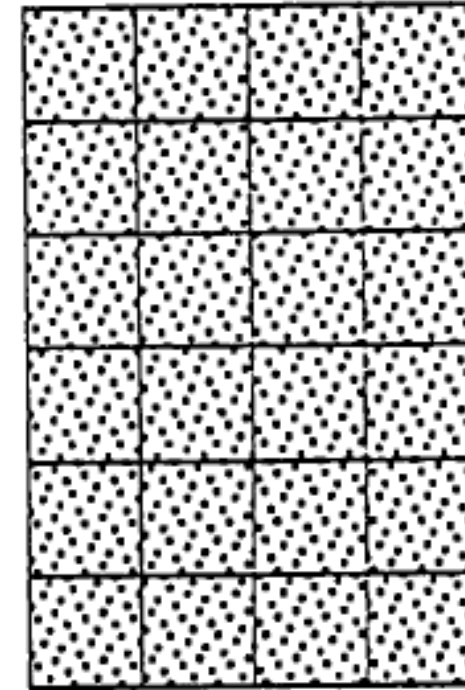

(c)

Considerations for barrel

- No more than half full
- Rotating barrel
 - internal vanes
- Reinforcement?
- Ideally end over end, or angled



Designing a subsampling tree

- Split a bulk down representatively
- Generate manageable portions
- Identify unique subsample identifiers

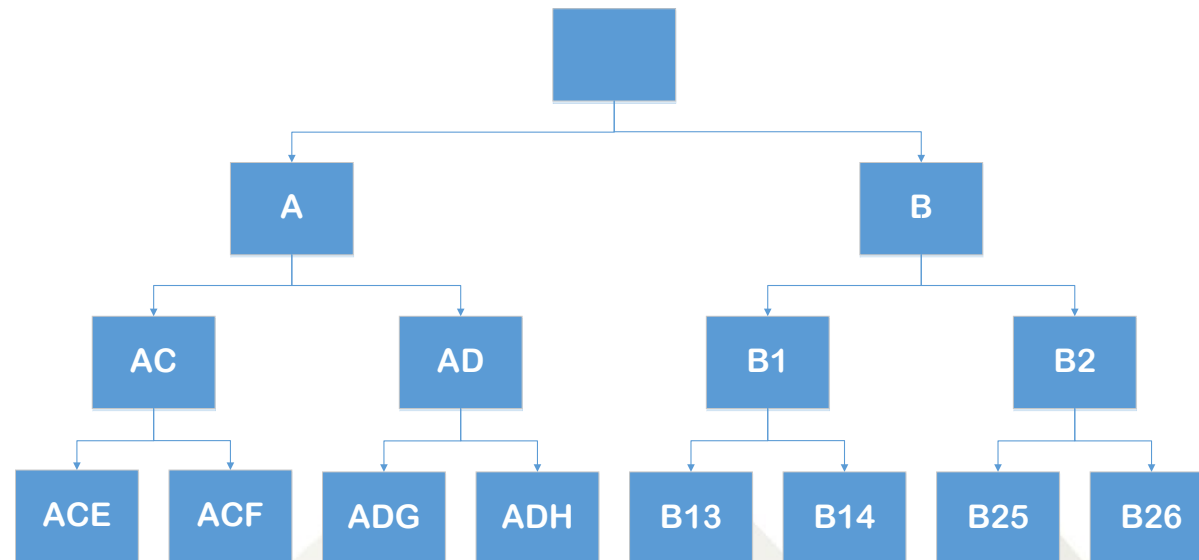

Representative subsampling

- Sampling plan to address controlling factors
 - Based on appropriate statistical methods
- Record client requested deviations for reporting
- Procedures for recording sampling data

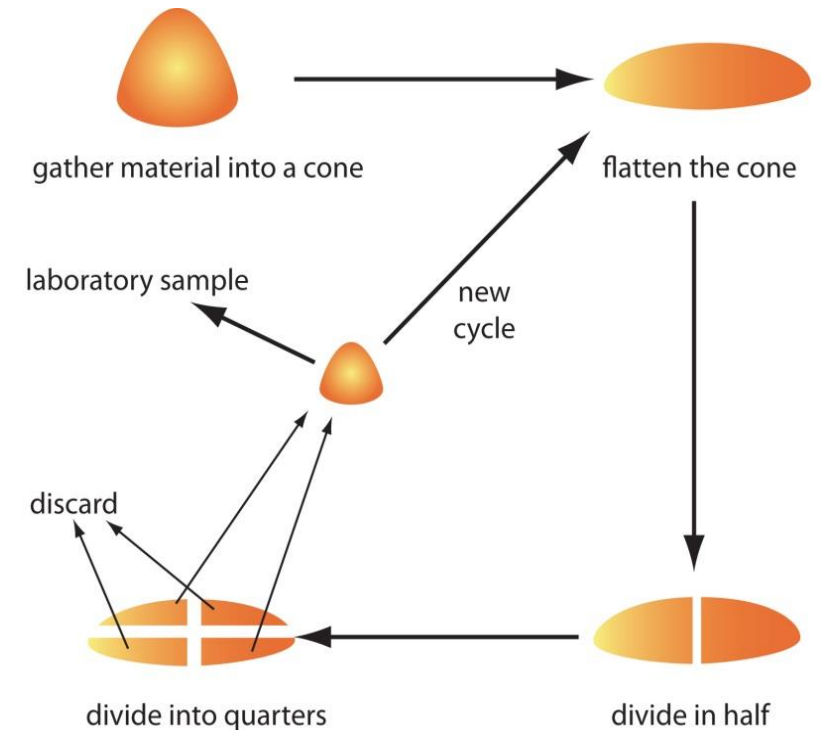
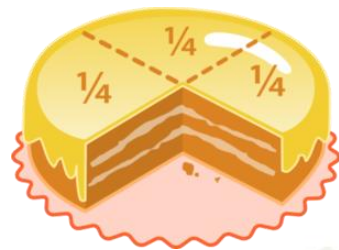

Representative subsampling

- Cone quartering
- Riffle splitting
- Rotary divider



Pathways to precision in soil analysis: advancing soil laboratories in Latin America and the Caribbean

Caminos hacia la Precisión en el Análisis de Suelos: avance de los Laboratorios de Suelos en América Latina y el Caribe

WORKSHOP | SANTIAGO - CHILLÁN | CHILE

8-11 APRIL 2024







Pathways to precision in soil analysis: advancing soil laboratories in Latin America and the Caribbean

Caminos hacia la Precisión en el Análisis de Suelos: avance de los Laboratorios de Suelos en América Latina y el Caribe

WORKSHOP | SANTIAGO - CHILLÁN | CHILE

8-11 APRIL 2024



Representative subsampling

- Cone quartering
- Riffle splitting
- Rotary divider



Repres

- Cone qua
- Riffle split
- Rotary div

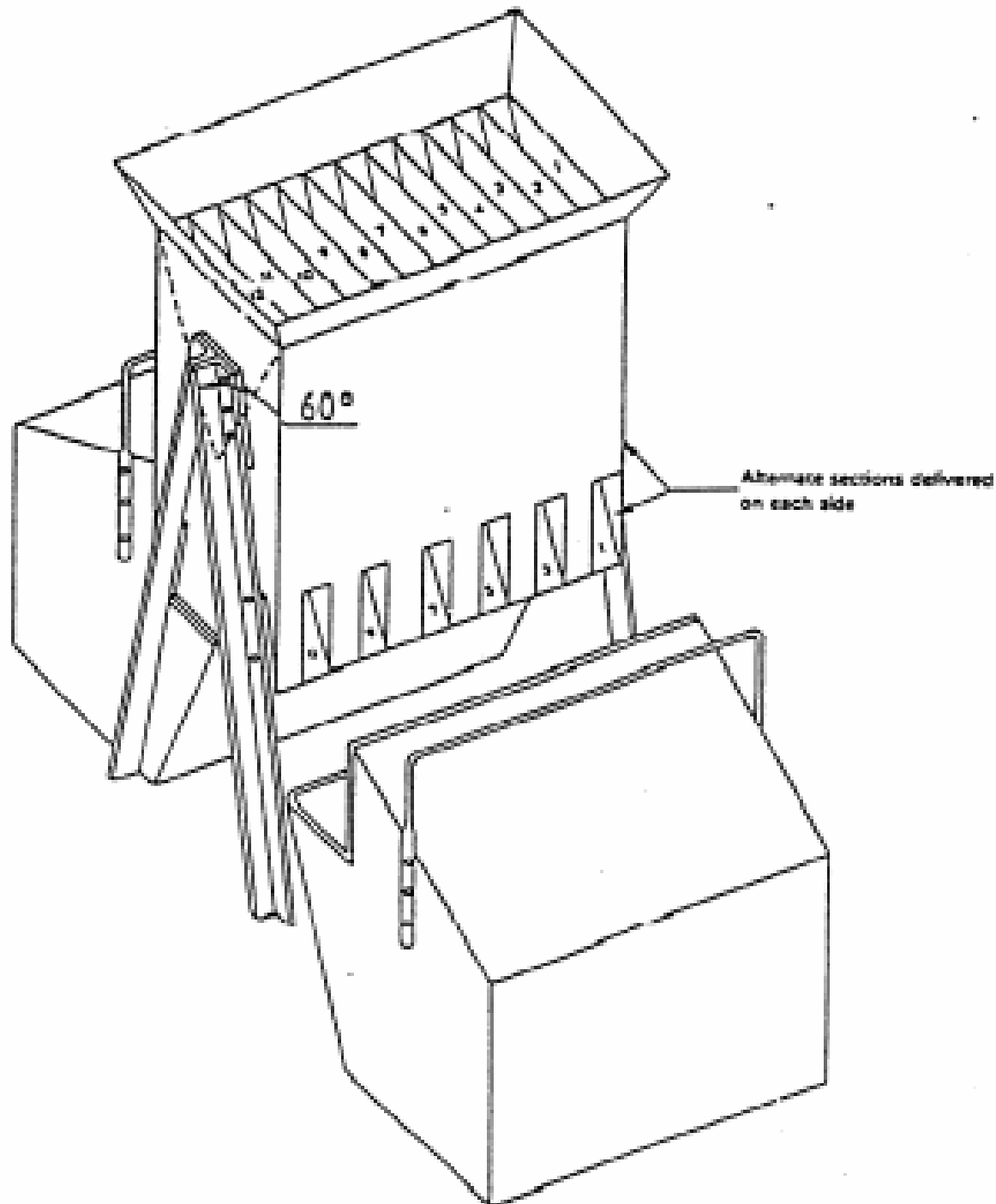



Temporary packaging

- If required
- Store labelled portions securely awaiting further dividing



Homogeneity testing

- We think we have a homogenous material – but we need to test this
- Random sampling to identify splits for analysis

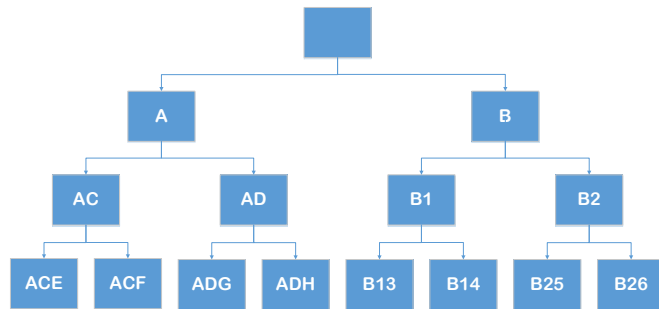

- Element selection...

Sample	Ni	Cu	Zn	...
	ppm	ppm	ppm	...
ADF4-3	19.9	11.9	78.1	...
B135-3	19.2	11.8	78.2	...
B137-2	21.1	12.0	78.0	...
ADE4-1	20.5	11.3	80.2	...
B262-2	19.8	12.0	78.0	...
B264-3	20.0	11.5	79.5	...
B251-3	20.1	11.7	77.5	...
ADE5-1	20.1	11.8	78.9	...
B251-1	19.6	10.8	76.1	...
ADF1-1	20.4	12.8	78.7	...
ACG7-1	20.7	12.2	81.6	...
B142-3	21.1	12.1	77.8	...
B137-3	19.8	11.1	77.9	...
B261-2	19.8	11.6	79.4	...
ADE5-2	20.5	11.8	78.3	...
...

Acceptance criteria

- Between-sample variability is not significantly greater than within-sample variability
- $F < \text{defined value, } F_{\text{critical}}$
- Confidence limits: 95%

$$F = \frac{\textit{Between sample variance}}{\textit{Within sample variance}}$$

Data analysis

- Identify statistical outliers
- Test for normality
- ANOVA - Analysis of Variance

Source of Variation

	<i>SS</i>	<i>df</i>	<i>MS</i>	<i>F</i>	<i>P-value</i>	<i>F crit</i>
Between Groups	945.8	23	41.1	1.1	0.4	2.0
Within Groups	883.5	24	36.8			
Total	1829.3	47				

Final splitting

- If required –
- use appropriate methodology as before

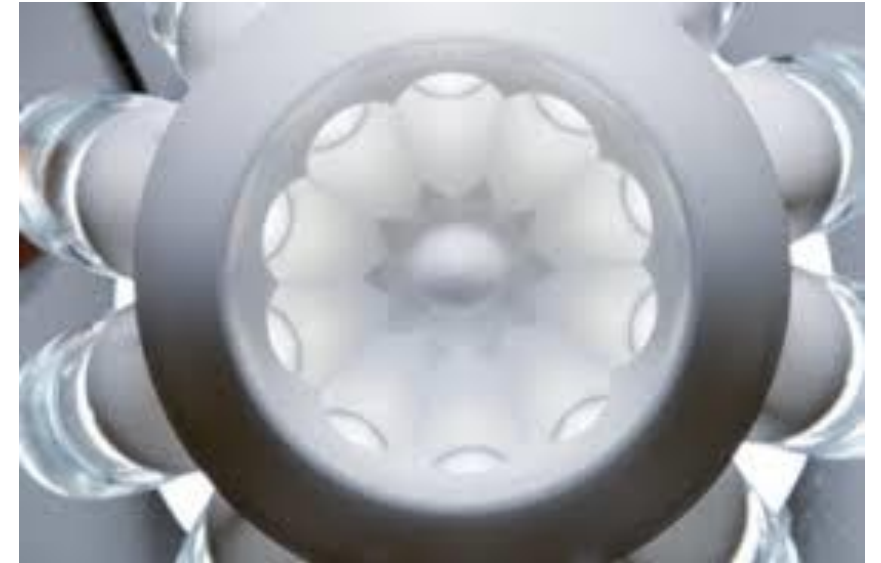

Storage options

- Container type
- Consider how this will be used, portion size etc.
- Susceptibility to change in air – sealing, inert gas?
- Susceptibility to settling?



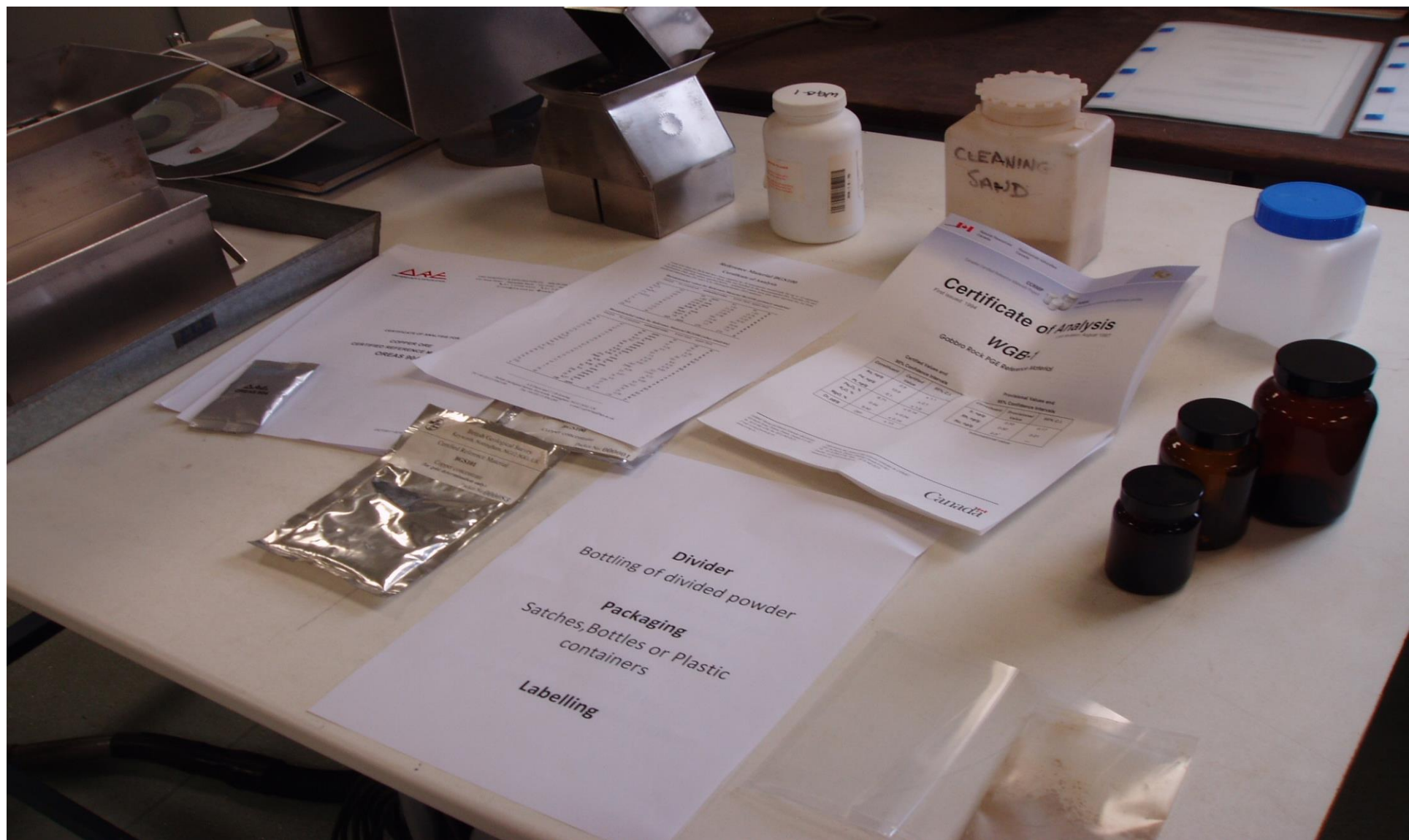

Pathways to precision in soil analysis: advancing soil laboratories in Latin America and the Caribbean

Caminos hacia la Precisión en el Análisis de Suelos: avance de los Laboratorios de Suelos en América Latina y el Caribe

WORKSHOP | SANTIAGO - CHILLÁN | CHILE

8-11 APRIL 2024



Documentation

- Measurand including analyte
- Measurement range (concentration)
- Matrix match and potential interferences
- Sample size
- Homogeneity and stability
- Measurement uncertainty
- Value assignment procedures (measurement and statistical)



When and why to use a Reference material

Pathways to precision in soil analysis: advancing soil laboratories in Latin America and the Caribbean

Caminos hacia la Precisión en el Análisis de Suelos: avance de los Laboratorios de Suelos en América Latina y el Caribe

WORKSHOP | SANTIAGO - CHILLÁN | CHILE

8-11 APRIL 2024



Assuring the quality of test results

- Quality Control (QC) procedures
- Record results - to view trends
- Statistical evaluation of QC data
- Plan and review monitoring of QC data
 - **CRMs, secondary standards**
 - Proficiency Testing schemes - EPTIS
 - Replicates and repeats
- Predefined acceptance criteria
 - **Shewhart chart – Westgard rules**
- Planned action to correct and prevent



Shewhart QC chart

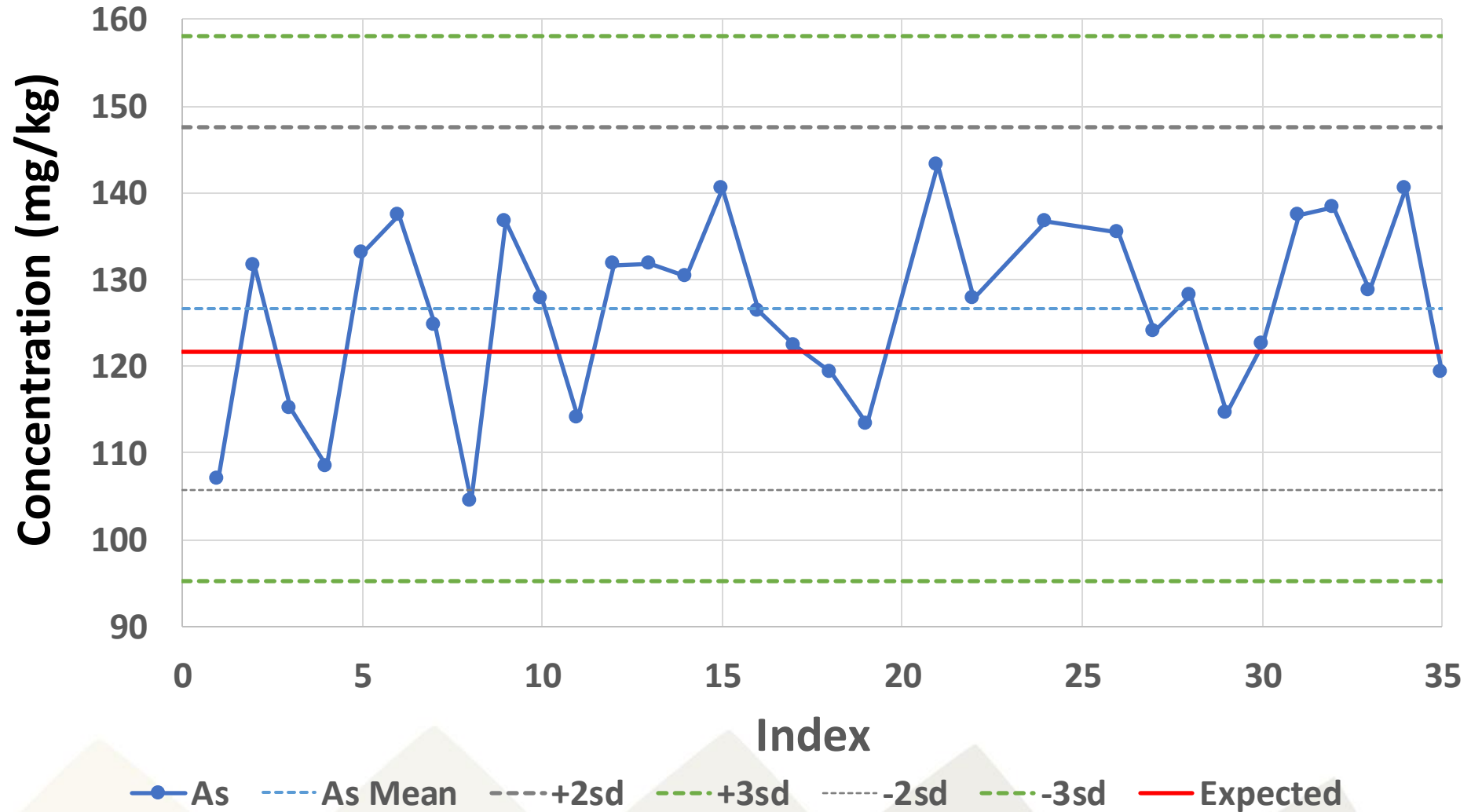

Enhancing data quality

Pathways to precision in soil analysis: advancing soil laboratories in Latin America and the Caribbean

Caminos hacia la Precisión en el Análisis de Suelos: avance de los Laboratorios de Suelos en América Latina y el Caribe

WORKSHOP | SANTIAGO - CHILLÁN | CHILE

8-11 APRIL 2024



Sources of error

- **Systematic error**
 - Can occur...
 - Will be minimised by careful planning
 - Aim to remove entirely

- **Random error**
 - Will occur
 - Can be quantified

Characterising Uncertainty

- Analysis gives one data value
- Each time a sample is analysed it will be slightly different
- Many sources of random error
- Combine to give a **method uncertainty**

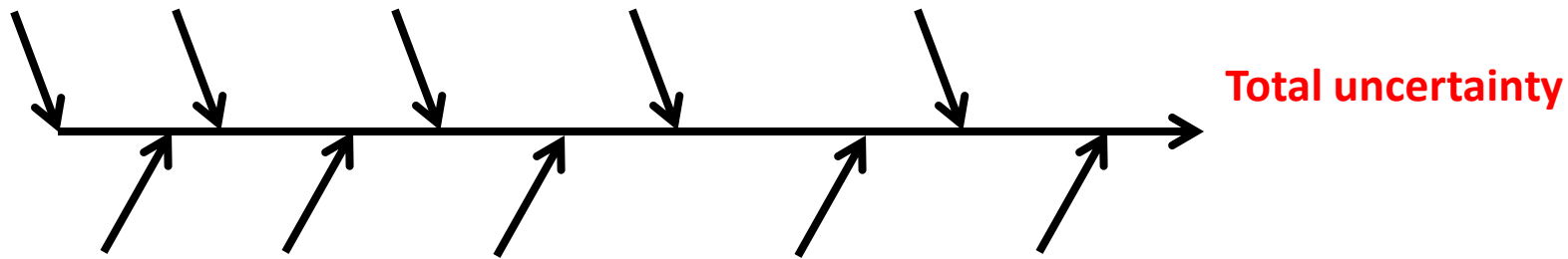

- Normal distribution – bell curve
- Allows calculation of 95% confidence limits
- Use error bars on graphs
 - allows meaningful data interpretation

Reference Materials do not have to be expensive

You can make your own with simple equipment

You can partner with organisations in your own country or region – help each other

Remember the GLOSOLAN PT programme – AFRILAB PT 2023



Food and Agriculture
Organization of the
United Nations



Thank you

