

Freshwater systems/Terrestrial systems

[An Overview of Rice-Based Small-Scale Aquaculture](#)

[Rice-Based Aquaculture in China](#)

[Enhancing the Performance of Irrigation Systems through Aquaculture](#)

[Rice and Fish Culture in Seasonally Flooded Ecosystems](#)

[Increasing Wild Fish Harvests by Enhancing the Rice Field Habitats](#)

[Polyculture Systems: Principles and Basic Considerations](#)

[Promoting Rice-Based Aquaculture in Mountainous Areas of Vietnam](#)

[Aquaculture in Stream-Fed Flow-Through Ponds](#)

[Short-Cycle Aquaculture in Seasonal Ponds](#)

[Low-Cost Aquaculture in Undrainable Homestead Ponds](#)

[Homestead Fish Culture: An Example from Bangladesh](#)

[Integrating Intensive and Semi-Intensive Culture Systems to Utilize Feeding Waste](#)

[Low-Cost Fertilization in Inland Pond Aquaculture](#)

[Culture of Fish Food Organisms and Biofertilizers](#)

[Feeds in Small-Scale Aquaculture](#)

[Decentralized Seed Production Strategy for the Development of Small-Scale Aquaculture](#)

[Small-Scale Eel Culture: Its Relevance for Rural Households](#)

[Small-scale *Macrobrachium* Culture in Bangladesh](#)

[Culture of Chinese Mitten-Handed Crabs](#)

[Aquaculture and Sewage Water Treatment](#)

[Water Quality Management for Freshwater Fish Culture](#)

Freshwater systems/Terrestrial Systems



An Overview of Rice-Based Small-Scale Aquaculture



Asian countries as rice-fish societies

Many countries in Asia can be called "rice-fish societies" in the sense that rice is the staple crop for basic subsistence, while fish is the main source of animal protein. The availability of rice and fish has long been associated with prosperity and food security. In Thailand, for example, the early inscription of the 13th century king, Ramkhamhaeng, states "in the waters are fish and in the field is rice" as an indicator of wealth and stability. In Vietnam, there is also a traditional saying that rice and fish are like mother and children.

The cultivation of most rice crops in irrigated, rainfed and deepwater systems offers a suitable environment for fish and other aquatic organisms. Traditionally a good deal of the fish for household consumption was caught from the paddy fields. With the conversion of wetlands into agricultural land and the intensification of rice production, this fishery has declined and farmers have turned to aquaculture as an alternative source of animal protein. It has to be recognized that such pressures have been uneven and there are still considerable areas of flood plain in the region where the fishery still offers an



adequate living to the local population.

In Cambodia, studies conducted by the Asian Institute of Technology (AIT) Aqua Outreach Program with the Department of Fisheries suggest that virtually all rice-farming households in the province of Svay Rieng, on the periphery of the Mekong flood plain, regularly collect substantial quantities of fish and other aquatic produce from their fields. A study in three communities in the district of Svay Theap showed an average per capita consumption of wild fish caught from ricefields and adjacent swamps of 25 kg. Each family member consumed 21 kg of other aquatic animals during the same period. During this period, virtually no fish or other aquatic products were purchased. The amounts caught vary according to the total amount and distribution of rainfall, with good rainfall early in the year increasing the catch.

The nature of this fishery varies with the season and the proximity of river systems. In Cambodia, in the wet season, the main fishery is in the rice field itself, as the fish move out of the main spawning grounds. The rice field fishery at this time is largely open access, signifying the relative abundance of the fish. The same is true for the cool season as the fish migrate back to the refuges. In the early part of the hot season, some farmers catch fish in deep trap ponds, some of them originally dug for fish culture by well-meaning projects. Some of the bigger trap ponds secure as much as 300 kgs of high value black fish, such as snakehead *Channa striata* (25-40% of the catch) or Clarias catfish (35-40%). These air-breathing species are well adapted to the swamp-like conditions of rice fields with fluctuating water levels and are highly appreciated wild fish in the capture system. They are carnivorous and will feed on other introduced fish but can be sold for twice the price of the equivalent cultured fish at local markets, as in Thailand. In Cambodia, they are also sold at high prices, leading Gregory and Guttman to claim that farmers in the areas are poor in all but fish. Clearly in such contexts, fish culture is unnecessary, although there are quite marked variations in the productivity of the fishery over rather short distances.

Rice-based aquaculture systems: Rice-fish culture or pond culture?

As the imperatives for a shift to fish culture emerge in rice-fish societies, an issue may be whether or not to try to replace the rice field fishery by developing culture in the paddy field or a pond. Culture in the paddy field attempts to recreate the environment of the rice field fishery, but with stocked and cultured species; pond culture effectively creates an additional artificial environment. It should be stressed that, even in pond culture, we are still talking about rice-based systems, since the farm economy where aquaculture takes place is usually still dominated by rice cultivation. In pond culture, the rice-based agricultural system offers resources for aquaculture but may also create and be constrained by competition in the use of those resources.

While these systems are often discussed separately in dealing with small-scale aquaculture, it is important to point out that, in many cases, farmers actually combine both. The pond is often linked to one or more of the surrounding paddy

fields at certain times of the year or in certain culture seasons to facilitate management of the rice crop and, if water is available, to extend the fish growing period. Fry are frequently stocked in ponds early in the season, but may be released into the paddy field to browse during the rice cultivation season, before returning to the pond when the fields are drained.

In developing aquaculture in rice-based farming systems, it is also important to understand the rich variety of those systems. At the broadest level of classification, rice is grown in irrigated, rainfed lowland, flood-prone, and upland ecosystems but very considerable differences exist within those systems. As is common in other traditional societies, rice farmers in South and Southeast Asia follow their own classification of rice lands, usually according to the level of inundation. For example, in Thailand and Cambodia,

in rainfed lowland rice systems, it is common to speak of lower paddies, middle paddies and upper paddies, which can usually be broadly recognized by the height of the bunds between the fields. In both countries traditional land holdings in rainfed areas were often composed of paddy fields of more than one elevation to offset the threat of crop loss from both drought and flood.



When rice fields were reallocated to individual households in Cambodia after the civil war, these principles were still used. The above classification refers only to rice lands, which can be cultivated normally in the rainy season. In Cambodia, there is a separate classification for lands which are too deeply flooded to allow wet season culture and can only be cultivated after the flood has receded.

Each of these types of paddy field is associated with different varieties of rice. Commonly, the higher paddies with limited water holding capacity tend to be associated with early maturing varieties or light rice. Lower-lying lands tend to be cultivated with late maturing varieties probably with a taller growth habit; these rices are usually called heavy rice. At the extreme level of flood, farmers often cultivate floating rice, with long stems that grow with the rise of the water. Of course, in areas of improved water control, such variations have largely disappeared and the traditional local varieties have, in many cases, given way to higher yielding varieties of rather uniform characteristics. However, in rainfed areas, the second and third generation improved varieties have had to be adapted to the specific local conditions.

Planting

The other key dimension of rice cultivation traditionally has been the planting method. Rice may be broadcast directly to the field or transplanted, that is grown in a seedbed in the early stages before being uprooted and replanted to the main field. The latter method enables farmers to start cultivation in areas with better water availability early in the season, to concentrate resources on the seedlings and to better control weeds. However, it is more labor intensive and difficult to practice on large plots and with limited labor supply. In general, the water levels in broadcast rice fields tend to be shallower, the plants closer together and yields lower. In an area of extreme out migration of labor such as Northeast Thailand, much of the rice land has been shifted in recent years from transplanting to broadcasting to save labor costs.

These variations in the nature of rice cultivation have implications for the feasibility and productivity of rice-based aquaculture systems.

Rice-fish culture

As a result of donors' and governments' focus on sustainable rural development, food security, and poverty alleviation, rice-fish farming systems have received a great deal of attention in the recent past. Several reviews on historical, socio-economic, and ecological aspects of rice-fish farming have been published in the past decade with either a global or a national focus. Country overviews have been provided for Bangladesh, China, India, Indonesia, Korea, Malaysia, Philippines, Thailand, Vietnam, and Madagascar. An extensive bibliography on diverse aspects of fish culture in rice fields was compiled recently.



In contrast to rice field capture fishery discussed above, farmers deliberately stock the fish in their fields either simultaneously or alternately with the rice crop. They raise them up to fingerling or table fish size depending on the size of fish seed available for stocking, the duration of the fish culture period (which may cover two successive rice crops), and the market need for fingerlings or table fish.

Technical details of the few physical modifications (bunds, trenches, water inlets and outlets) required to make the rice field suitable for fish farming have been described elsewhere. It is, however, interesting to note the differences in refuge shape and size. The refuge can be a pond within or adjacent to the rice field, or a trench which may be central or lateral, or a combination of the two. Very great differences in the size of the refuge area can be observed. For religious reasons, farmers just dig a small sump in the rice field terraces in the Ifugao province in the Philippines while in Vietnam up to half the rice field is sometimes dug up because profits from fish sales exceed those from the rice crop.

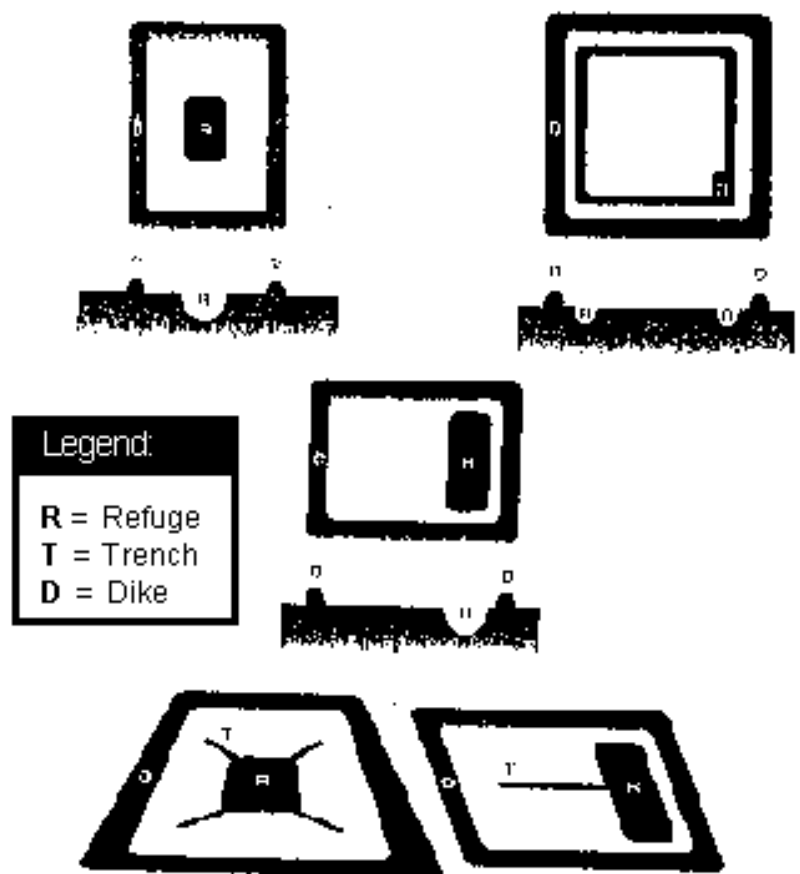

As noted above, traditional rice varieties are selected by the farmer for their suitability to agroclimatic conditions, topography, and also consumer taste. The local rice varieties are an important part of the wide biodiversity of plants and animals found in such systems. In large parts of Asia past increases in rice yields have mainly come from the gradual reallocation of land from traditional to the high-yielding modern varieties.

Features of high yielding modern varieties

- Short
- Stiff-strawed
- Fertilizer-responsive
- Photoperiod-insensitive
- Short to medium growth duration (100-130 days).

The use of longer-stemmed and longer-maturing traditional varieties allows a higher water table and an extended period for fish farming. Although much of the expansion of rice-fish farming in the 1980s has been perceived to be associated with traditional rice farming, the case of the P.R. China with about 1.2 million ha under rice-fish farming in areas almost exclusively planted to modern varieties shows that the use of new rice varieties is not a constraint for rice-fish farming. Deepwater rice varieties are adapted to grow quickly with rising water levels reaching several meters deep. The farming of fish in these waters must be community-driven as individual property rights cannot be distinguished anymore.

Costs for stocking and keeping fish within fenced areas may be high but can be shared among members. More importantly, the importance of capture fisheries and particularly access to these resources by the landless are issues of concern in deepwater rice-fish systems.

Cultured fish species

Many fish species are cultured in rice fields but only a few are commercially important. Fish species cultured in rice-fish farming:

- omnivorous common carp *Cyprinus carpio*; and
- planktivorous Nile tilapia *Oreochromis niloticus*. They feed low in the food chain and are therefore preferred species in the culture systems.
- Other popular species
- *Barbodes gonionotus*
- *Trichogaster* spp.

Often, the locally found wild fish such as snakehead *Channa striata* or smaller indigenous rice field species not only play an important role for food security and a balanced nutrition but are also important sources of income.

While farmers generally tend to exclude predatory fish from their stocked rice fields, farmers in Northeast Thailand allow the fish to

enter the field although many of the stocked fish fall prey to the wild species. This is, however, acceptable due to the high market value of the wild fish at local markets.

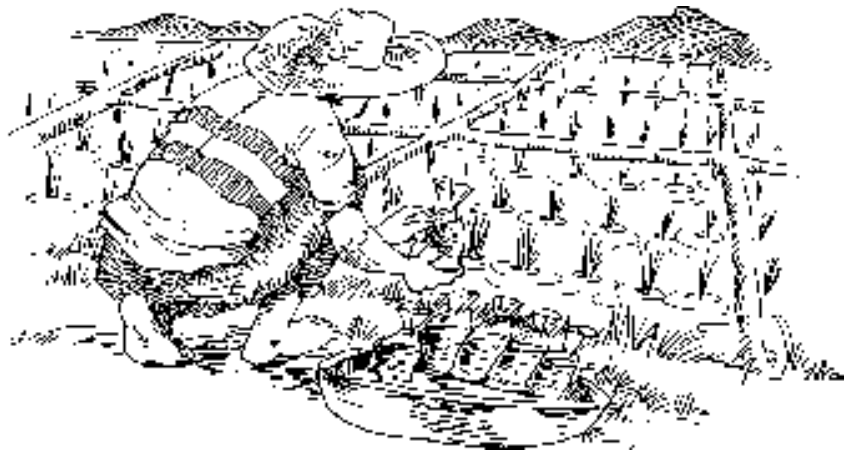

Stocking

The stocking densities used in rice-fish farming vary widely. In general terms, with a low number of fish stocked in the field, naturally occurring rice field organisms are readily available as "free fish feed". In low stocking densities, overall costs are lower and therefore this practice may be more suitable for resource-poor and risk-averse farmers who are still experimenting with their farming system. Higher stocking densities require additional fertilization and supplementary feeding. Feed resources from the farm are widely used for that purpose, particularly rice bran (although the alternative uses of bran have to be considered). Farmers may supplement the readily available, naturally occurring fish food organisms in rice fields by collecting supplemental feed from the rice field and surrounding wetlands. An example is the regular collection by

hand of bigger golden apple snails (which the fish could not eat directly) by farm household family members who crush them into fish feed sizes.

Generally, integrated pest management (IPM) practices are recommended for rice-fish farming. The use of pest and disease-resistant rice varieties is encouraged minimizing the need for pesticide application. In rice monoculture, the chance of pests reaching a population level to justify control action is usually low. Potential income from fish would outweigh pesticide costs. Also, from an IPM point of view, fish culture and rice farming are complementary activities because it has been shown that fish further reduce pest populations. Evidence from the FAO IPM Intercountry Program in Indonesia shows that, through IPM, the number of pesticide applications in rice can be reduced from 4.5 to 0.5. This not only saves costs, but eliminates an important constraint in the adoption of fish farming. Therefore training in IPM for many farmers participating in the regional program in Bangladesh, Indonesia, or Vietnam has been an entry point to start rice-fish farming.

Simultaneous culture of fish and rice often increases rice yields, particularly on poorer soils and of unfertilized crops, probably because under these conditions the fertilization effect of fish is greatest. With savings on pesticides and earnings from fish sales, increases in net income on rice-fish farms vary considerably, but they are significant, with up to 100% reported increases when compared to returns from rice monoculture farms.

Selected economic indicators for the comparison of rice and rice-fish farming			
Indicator	Country	Change(%)	Comments
Increase in rice yield equivalent	Indonesia	+20	Research station results, fish yield expressed expressed in rice equivalent
Income from fish as percent of total farm income	Malaysia	+7-9	Figures for owners and tenants in double rice in double rice cropping area, respectively
Net return	Philippines	+40	Summary of results from nationwide field trials during the late 1970s to 1987 in irrigated rice areas
Net return	China	+45	Results from four farm households in Hubei Province
Net return	Thailand	+18 -35	Figures for research station and farmer field, respectively
Net farm income	Thailand	+65	Difference in rice yield equivalents

Cases with net return higher than rice monoculture	Thailand	+80	20 out of 25 farms had higher net-returns from rice-fish farming than from rice monoculture
Net benefit	Bangladesh	+64 +98	Net benefits are higher in the aman or wet season and lower in the boro or dry season
Net profit	Vietnam	+69	20% of the trench construction costs considered in capital costs. Operating costs increased by 83% for labor and 100% for irrigation, but had savings in the use of pesticides
Total farm cash	Vietnam	0	Mekong Delta, beneficial and net effects thought to be related to environmental sustainability, system biodiversity, farm diversification and household nutrition

Small pond aquaculture in rice-based agriculture systems

In small pond culture in rice-based agricultural systems, the key issue for aquaculture is resource availability. As the dominant element in the farm economy, the rice field is often the key resource for fish culture. The rice field offers several potential resources for fish culture, including rice itself. Aquatic plants such as duckweed and morning glory and a variety of other organisms including rice pests may be gathered as feed for fish (e.g., snails and termites).

Milled rice offers two potential products for fish feed, the rice itself, either cooked or uncooked, and rice bran, which can be mixed with other feed or given separately. The latter is often favored in the region since it allows farmers to observe their fish at regular intervals. Naturally the availability of rice bran depends upon the yield of rice obtained. Higher yielding systems will potentially have more rice bran available. In Vietnam, for example, double-cropped rice in the so-called intensive zone of the Red River delta may offer up to 12 tons of rice per ha per year, providing almost a ton of rice bran. In contrast, the less intensive systems manage a total production of only half that amount. Unfortunately, there are other factors in the equation which have emerged with modernization. In Thailand, little of the bran from milling rice returns to the farmers. The bran is retained by local millers, who mill the rice for free, for rearing pigs. Farmers needing rice bran have to buy it from the market. In a sense, therefore, fish culture competes with the livestock sector's demand for the available rice bran as feeds. In Vietnam, bran mixed with aquatic plants is often used as feed for pigs, rather than feed for fish. Pig manure becomes available as an input for fishponds. The more intensive the systems are, the higher the tendency to have more available manure. The balance in the use of these resources will be decided on

economic grounds. In southern Vietnam, in recent years, prices of pig meat have declined discouraging farmers from keeping pigs. However, if they produce local alcohol from rice, the resulting waste becomes a free source of feed for the pigs whose manure is used in fish culture.

Another essential part of the typical rice-based farming system in Southeast Asia is draught livestock, usually water buffalo, kept for plowing, harrowing and transport of seedlings and harvested rice. Livestock also offers a potential source of pond fertilizers for fish

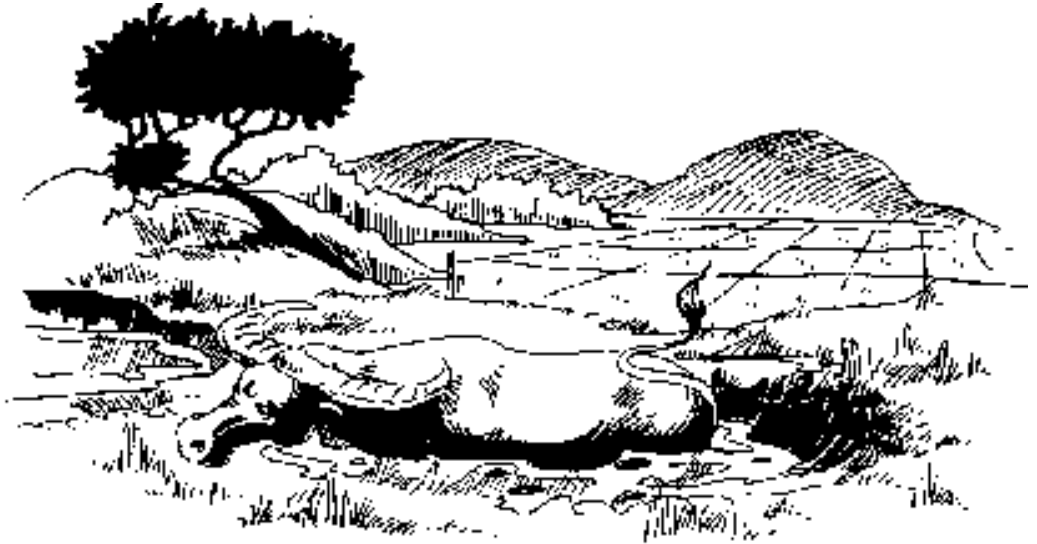

culture, although ruminant manure in general is poor in nitrogen. Once again, however, availability depends on possible competition for resources. Where buffalo are gathered in stalls at night, manure is traditionally used as fertilizer for seedbeds and paddy fields, especially in areas of low fertility away from the flood plains. Ruminants may also compete for the use of pond water, particularly where water is at a premium as in Northeast Thailand. The problem with such areas is that the rice-based farming system offers a very limited source of nutrients. While recommendations for low-cost fish culture for poor farmers usually stress the use of on-farm inputs, the typical rainfed rice-farming system in the more inland areas of the region rarely offers an adequate nutritional base for fish. After many years of work in such areas, the AIT Aqua Outreach Program has concluded that on-farm resources need to be supplemented by inorganic fertilizers if fish production is to achieve more than subsistence yields.

Prepared by:
Harvey Demaine and Matthias Halwart

Rice-Based Aquaculture in China

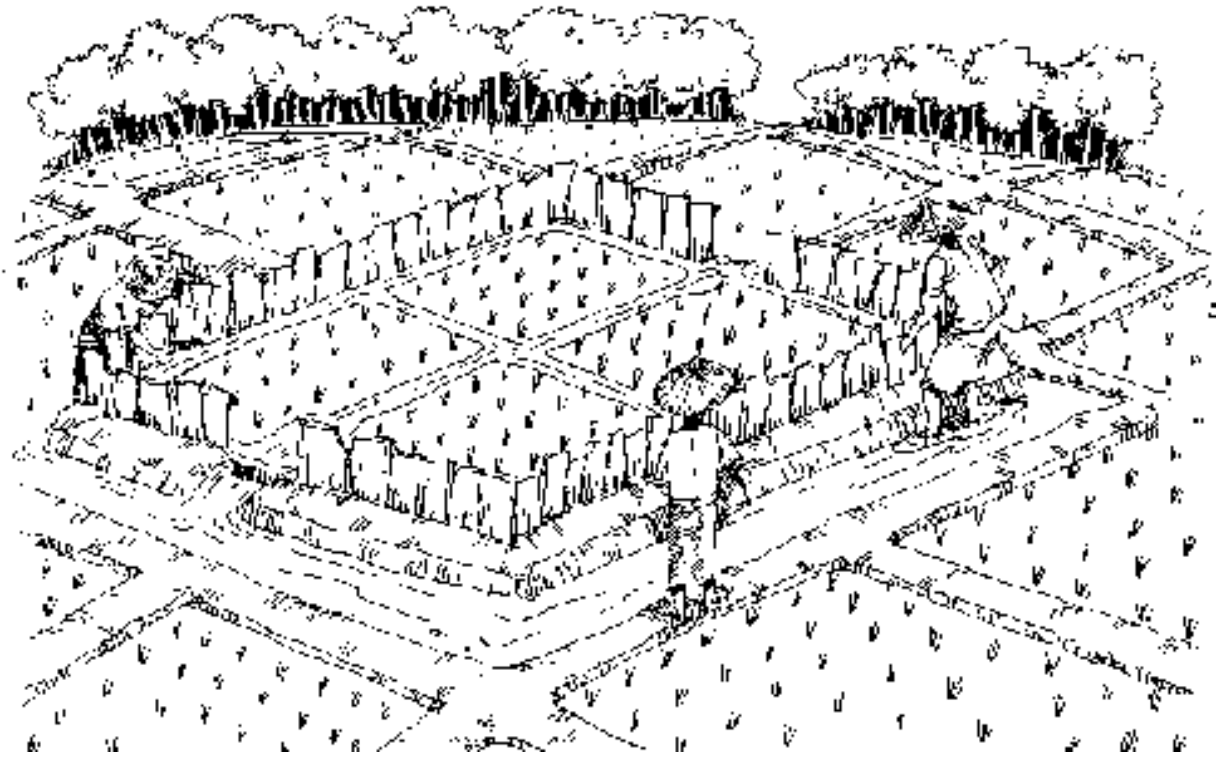

Rice-fish culture is traditionally practiced in many rice-growing provinces in China. Traditional rice-fish culture is mainly used to obtain additional protein for household consumption. However, recent developments in rice field-based aquaculture focus more on the economic benefits of this family-scale business. Over 6.7 million hectares of rice lands can be brought under these systems.

Aquaculture commodities grown in a rice field result in significantly higher levels of income than when rice is grown alone. The price of fish is twice that of rice grain. In recent years, higher value aquaculture species, such as mitten-handed crabs and freshwater prawns, have been chosen by farmers for culture in their rice fields. The prices of freshwater prawns and mitten-handed crab are 10 - 50 times higher than that of rice, thus making these attractive economic propositions.

Facts

As of 1997

1.67 M ha Total area of rice-fish culture producing about **700,000 tons** of marketable aquatic animals

419 kg/ha Average annual yield

By year 2000, it is expected that the total rice-aquaculture area will reach **3.3 M ha**, covering about half of the total rice field area suitable for rice-fish culture in China.



In 1995-1997, an extension project for rice-aquaculture in Jiangsu Province in the lower reach of Yangtze River was carried out. The rice-aquaculture system was popular with local farmers, especially those who do not have access to water bodies, such as ponds and lakes, suitable for other types of aquaculture. As a result, the rice-aquaculture area expanded radically from 19,606 ha in 1995 to 68,973 ha in 1997, growing Chinese mitten-handed crab, local and exotic prawns and finfish.

	Total area of culture (ha)	Total production of animals (kg)	Average yield of animals (kg/ha)	Profit (US\$/ha)
Rice-crab	36,113 (52.4%)*	16,245,000	450	2,898
Rice-prawn	13,867 (20.1%)*	5,712,200	411.9	2,536

* Percentage of the total rice aquaculture area

Models for integrating aquaculture into rice fields

Rice field renovation

The rice field is renovated to include the following elements:

- elevated embankment to keep water and prevent cultured species from escaping;
- ditches or trenches, sumps and refuges to provide shelters. The dimensions of these structures of different patterns depend on the farmed species. The structures should occupy about 15-20% of the total area;
- sluice gates for inlet and outlet to regulate the water level to prevent losses; and
- fence or enclosure of appropriate height, shape and materials to restrain crabs and frogs.

Rice cultivars with strong stems should be planted. The variety should be able to tolerate manure application, especially if feeding and fertilization are applied during rice-fish culture. When the soil becomes very fertile, rice plants tend to lodge. However, there is scanty information about rice cultivars in rice-fish fields. Suitable rice cultivars for use in rice-fish culture have to be developed.

Rice-fish culture

The species used for rice-fish culture should meet the following requirements:

- availability of quality fry and fingerlings in desired quantity;
- desirable herbivorous or omnivorous feeding habits;
- tolerance of high water temperature and low dissolved oxygen level at night; and
- desirable growth rate/performance.

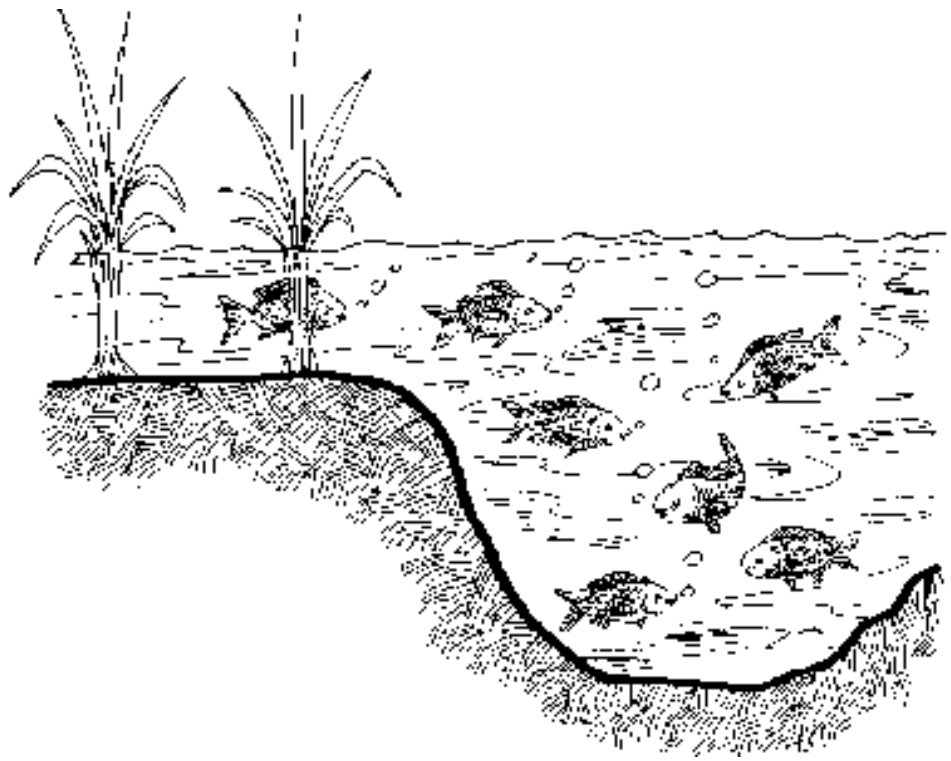

Species for stocking

Polyculture is used in most rice-fish culture systems. Several field-tested stocking models are available depending on the local situation.

Most commonly used fish species for polyculture in rice fields are:

- Common carp – *Cyprinus carpio* (several different strains or varieties)
- Grass carp – *Ctenopharyngodon idella*
- Crucian carp – *Carassius auratus*
- Tilapia (*Oreochromis niloticus*)
- Catfish (*Clarias gariepinus* gives high yields but its price is low due to poor acceptance by consumers. The hybrid between *C. gariepinus* and local catfish *C. fuscus* is better because of improved taste and high tolerance of undesirable environment conditions).

Rice-fish culture is not a particularly good method for growing very young fish to fingerling size (about 3 cm) because of low survival rate. Nursery ponds are better for fingerling production.

Rice-crab culture

The culture of Chinese mitten-handed crab (*Eriocheir sinensis*) developed rapidly since 1994 probably because of high market value. A single crop of rice in a year is suitable for crab nursing or grow-out culture. To grow crabs in the rice field, a

peripheral trench should be dug with the following dimensions: width, 4-6 m. and depth, 1.2-1.5 m. Aquatic weeds should be planted in the water to provide shelter for crabs.

Crabs can utilize the natural food produced in a rice field by manuring or fertilization activities for rice. Artificial feeds are applied for crab culture. One-third of the water in the field should be changed every 10-15 days to maintain desirable water quality (especially towards the end of the crop cycle). Dirty water often leads to molting problems and poor appearance at harvest (and low prices). During culture, the use of chemicals toxic to crabs should be avoided. Harvesting should be done before the temperature drops to 12°C to prevent crabs from burrowing into the mud.

Stocking and expected harvest of crabs		
Stocking size	40-100 individuals/kg	80-160 individuals/kg
Stocking density	75-100 kg/ha	60-120 kg/ha
Stocking time	February - March	
Expected harvest	300 - 450/ha	
Average crab size at harvest	125 g	

Rice-prawn culture

The culture of native freshwater prawn *Macrobrachium niponensis* or the exotic freshwater giant prawn *M. rosenbergii* is a relatively new aquaculture practice in rice fields. Though the native species is smaller than the exotic prawn, it demands a higher price in the domestic market.

Preparation of a rice field for prawn culture is similar to that for crab culture. For local prawn, *M. niponensis*, brooders carrying fertilized eggs are stocked between mid-May and mid-June in a small cage installed in the sump for hatching. Brooders, along with the small cage, are removed after the hatching of eggs. The stocking density per hectare is 3-3.75 kg of 4-6 cm brooders. Larval development, which lasts about 15-20 days, takes place in the rice field. Natural food organisms and supplementary feeds like soybean milk greatly influence this development. Larvae estimated at 225,000-300,000/ha continue to grow in the field up to November. Crushed snails, clams and commercial prawn pellet feeds are applied during grow-out. The feeding rate is 0.5 kg per 10,000 prawns. This is increased by 0.5 kg every two weeks.

Harvesting is done in late November to December. Market-size shrimps are taken out and sold live. The small ones are returned to the fields for further growth.

For *M. rosenbergii*, seeds are purchased from hatcheries and the post-larvae stocking density in the rice field is 30,000 per ha. The routine management is similar to *M. niponensis*. Harvest should be done in October before the temperature drops.

References

- Birley, M.H. 1998. Internet Conference on Integrated Bio System, 1998.
- Jianzhong, B. 1997. The 6th Industrial Revolution: Symposium of the Industrialization Strategy of Modern Agriculture: A review. S & T Daily.
- Kangmin, L. 1988. Rice-fish Culture in China: A Review, *Aquaculture*, 71 (1988) 173-186.
- Kangmin, L. and P. Yinhe. 1992. Rice Fields as Fish Nurseries and Grow-out Systems in China. In ICLARM Conference Proceedings 24. 457 p.
- Mingsen, Z. 1994. Rice Crab Culture Techniques. *Journal of Aquaculture* 1994 (2).

Conclusion

- Despite the loss of area for the rice crop resulting from excavations undertaken specifically for fish culture, rice production increased by 10%-15%.
- Rice-aquaculture farming does not alter the basic function of rice fields to produce grains. Aquaculture does not compete with crops for land.
- Rice farming and aquaculture on the same piece of land complement each other with no adverse impact on the environment. The use of chemicals for rice cultivation is minimized by the introduction of aquaculture. Rice-fish culture also helps eliminate mosquito larva and vector organisms.



Neng, W., L. Guohou, L. Yulin and Z. Gemei. 1988. A Role of Fish in Controlling Mosquitoes in Rice Fields. In K. MacKay, ed. Rice-Fish Culture in China. p 213-215.

Qinghe, H. 1998. 21st Century Calls for Feed Revolution. Science & Tech Daily 11 April.

Yin P. 1985. Fish and Frog Culture Techniques in Paddies. Jiangxi Provincial Fisheries Research Institute, Manuscripts.

Prepared by:
Li Kangmin

Enhancing the Performance of Irrigation Systems through Aquaculture

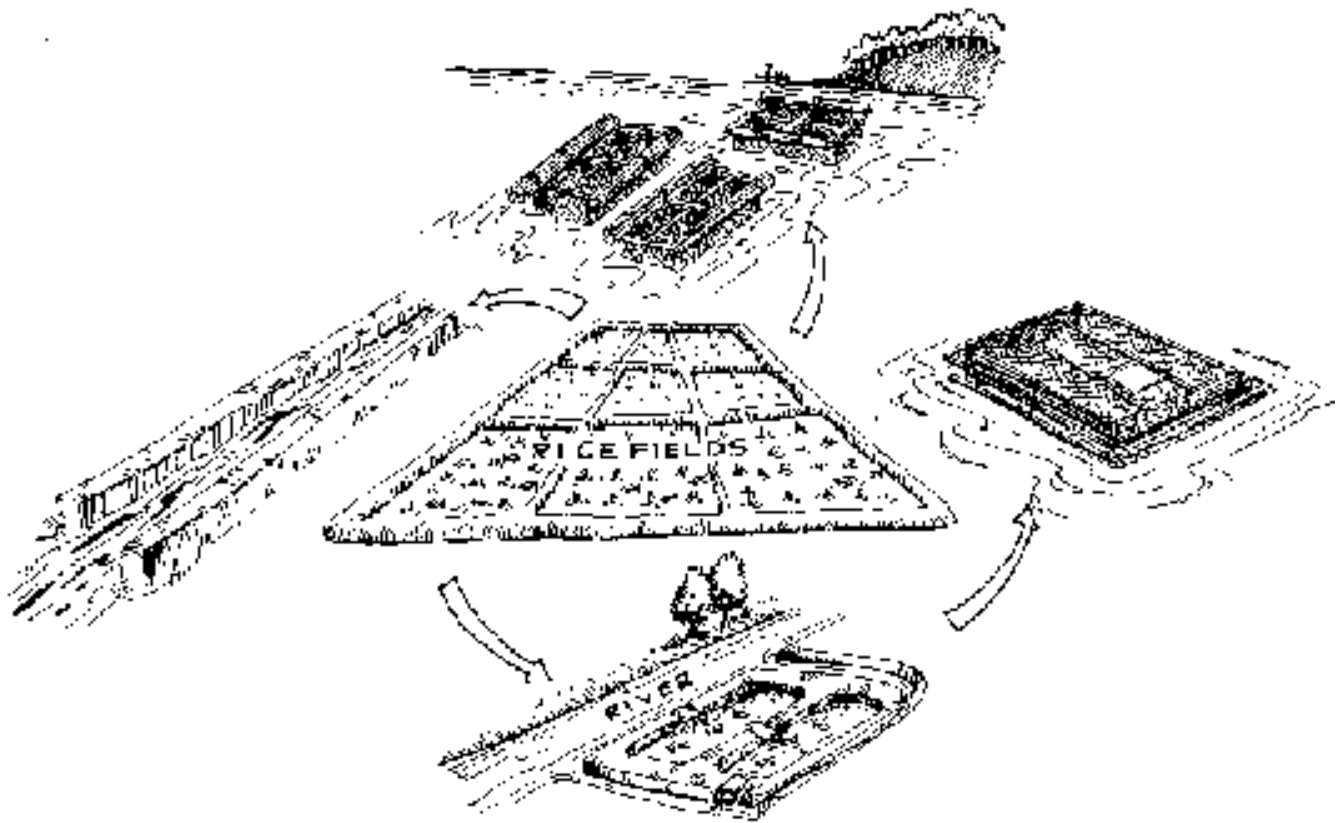

Harvesting fish from irrigation systems, sometimes involving some form of husbandry or even culture, has been a long time practice. Although seldom recorded, it seems to have been widespread in the tropics and subtropics, especially in rice fields. Improved management of land-based crops and the successful raising of aquatic organisms were not generally considered to be compatible. But with the advent of integrated crop protection (e.g., integrated pest management), this situation has changed.

Irrigation systems using stored or diverted water have increased exponentially during the past 50 years, but the expansion of fish farming within these irrigated systems has not kept pace. The integration of fish farming could significantly mitigate some of the negative effects associated with irrigation systems, such as an increase in human disease vectors.

Water use imperative

Currently, water scarcity is emerging as the dominant constraint in efforts to expand food production. Increasing irrigation efficiency and water productivity – getting more crops per drop – must therefore become one of the top priorities. Integrated water resources management is now widely recognized as a basic principle of water management.

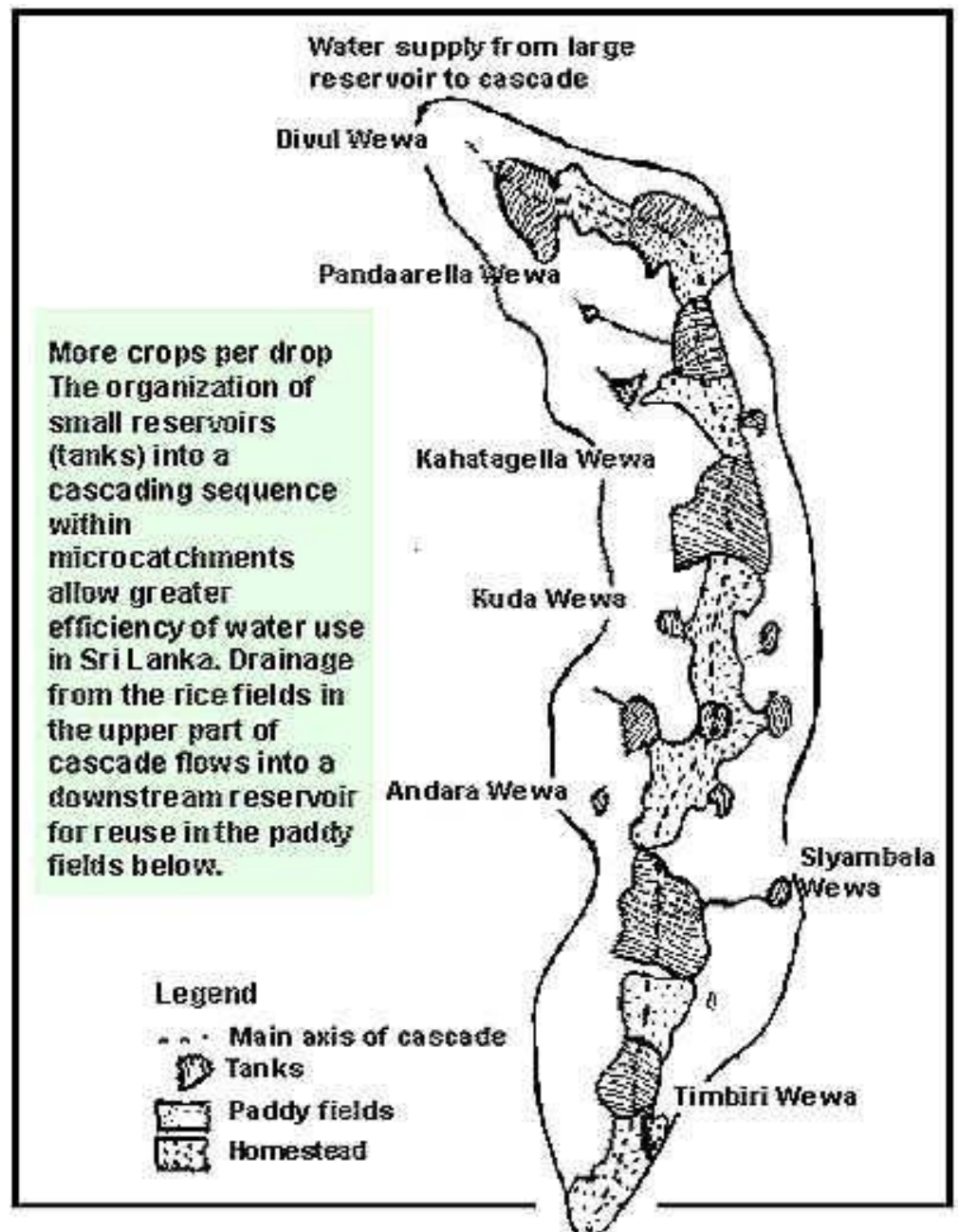

Possibilities for integration

An approach to fish farming development at the irrigation system level is proposed. The reservoir fishery, particularly in large shallow reservoirs as found in Sri Lanka, is highly productive. The farming of fish in Chinese reservoirs has also resulted in spectacularly high yields. The culture and capture of fish in irrigation canals are practiced in several countries such as Egypt, Pakistan, China and Thailand. Pond culture can be highly productive as Chinese and other Asian

Potential sites for nursing or grow-out of fish

- Small and large irrigation reservoirs
- Extensive network of main and secondary irrigation canals and main drainage canal
- Irrigated fields
- Adjacent ponds and night storage ponds
- Aquatic refuges of various sorts



experiences show, and fish capture and culture in rice fields have received new impetus with the increasing spread of integrated pest management practices. Even though substantial profits can be achieved when fish farming is done in individual irrigation components, it is proposed that the development of fish farming in several or all components of the system is more likely to succeed because it will alleviate constraints that are inevitably encountered if only one component is developed (Fernando and Halwart, 2000).

An example is the use of rice fields as fish nurseries. If only rice fields were used for fish farming, the fish harvested at the end of the cultivation period would generally be too small for human consumption. However, if the fingerlings can be sold for grow-out in other components of the irrigation system, e.g., reservoirs or canals, the constraint of harvesting small, unmarketable fish can be overcome. On the other hand, grow-out operations are often constrained by limited fish seed supply. The demand for fingerlings can be met by rearing fish fry in nearby rice fields under concurrent or rotational systems.

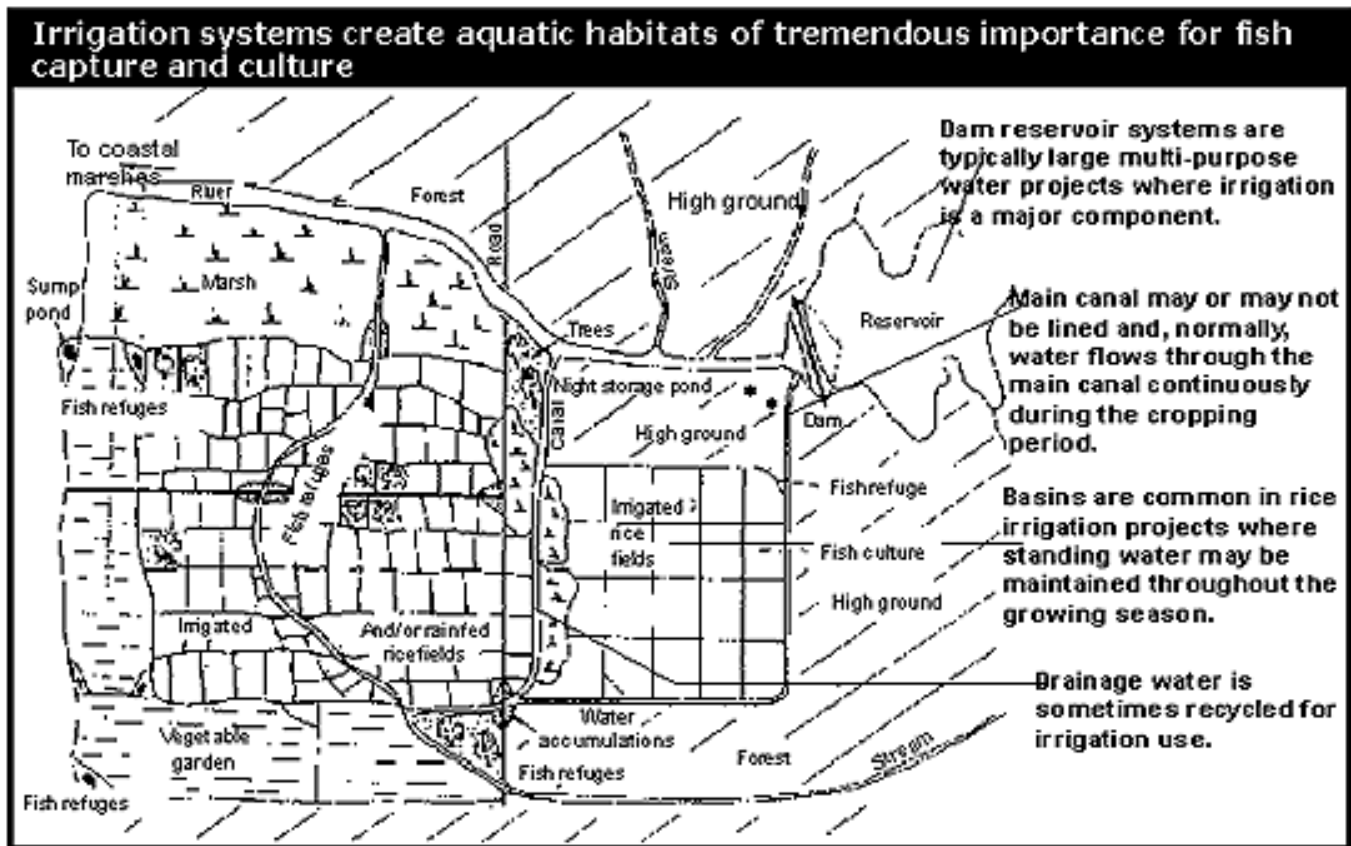

For example, stocking material of species suitable for reservoirs can be obtained from irrigated rice fields where the short maturation period of the crop only permits the harvest of fingerlings. If a pragmatic and flexible approach is applied to use all aquatic habitats for fish production and conservation, there could be a year-round supply of fish and a minimum of wastage of stocks of cultured fish.

In many countries, fish seed is now relatively accessible even in inland areas.

Permanent water bodies should be stocked with a central pool of culture species harvested from short-lived habitats serving as nurseries. A flexible system of moving culture fish within the system of habitats should be feasible.

The use of high-yielding fish of good quality is essential for economic viability. In areas where a high diversity of fish with the requisite biomass of desirable species already exists, the indigenous fish can be harvested. However, the yields may only be adequate for low-income rural areas. Common carp has been a preferred cultured species. Tilapia is proposed as an alternative because the fish is cheap to raise, gives high yields and is quite palatable.

Aside from economic revenues, this type of integration also leads to ecological and social benefits. High densities of fish in irrigation systems enhance the yield of land crops, minimize crop pests, and reduce the populations of vectors of diseases in man and domestic animals.

From a planning and development perspective, the major challenge for the future of fish farming in irrigation systems is likely to be related to issues of inter-agency coordination, consultation and, in some cases, external mediation to harmonize interests of the different line agencies.

Utilizing several components of the irrigation system can boost fish production – From rice field nursery to cage grow-out

Traditionally, rice-fish systems in West Java, Indonesia, supplied seed fish for further growing in family ponds and fish for direct consumption by people living within the rice-growing districts. Fish markets increased in size due to tremendous population pressures in West Java. The number of ponds and rice-fish systems also increased. Running water systems moved from the laboratory to commercial-scale, increasing the demand for seed fish and contributing to the expansion of rice-fish and pond nurseries. In the 1980s, demands for freshwater fish continued to expand, but the number of traditional fish ponds remained relatively constant due to urbanization. Rapid development of reservoir cage culture created increased demand for seed fish for stocking, resulting in further expansion of rice fish nursery systems.



In the Cianjur and Subang Regencies, West Java, a combined minapadi-penyelang nursery system produced four crops of fish and one crop of rice with total yields of 370 kg/ha and 5,667 kg/ha, respectively, in six months. (Costa-Pierce, 1992).

The Challenge: Consultation and Coordination

The participation of all resource users and other stakeholders at an early stage is indispensable to effective land use planning and zoning, not least because of their intimate knowledge of local socio-economic conditions and the state of natural resources. At the government level, the functions of the various agencies with regulatory and development mandates need to be well coordinated. Two broad distinctions can be made in the wide range of possible institutional arrangements leading to integrated planning and development at irrigation system level:

- **Multisectoral integration.** This involves coordinating the various agencies responsible on the basis of a common policy and bringing together the various government agencies concerned, as well as other stakeholders, so they can work towards common goals by following mutually agreed strategies.
- **Structural integration.** Here, an entirely new, integrated institutional structure is created by placing management, development and policy initiatives within a single institution.

Multisectoral coordination tends to be preferred, since line ministries are typically highly protective of their core responsibilities, which relate directly to their power base and funding. The establishment of an organization with broad administrative responsibilities overlapping with the traditional jurisdictions of line ministries is often likely to meet with resistance rather than cooperation. Integration and coordination should be considered as separate but mutually supportive.

Source: Willmann, Halwart and Barg. 1998.

References

- Costa-Pierce, B.A. 1992. Rice-fish Systems as Intensive Nurseries, p. 117-130. *In*: C.R. dela Cruz, C. Lightfoot, B.A. Costa-Pierce, V.R. Carangal and M.P. Bimba (eds.) Rice-fish research and development in Asia. ICLARM Conf. Proc. 24, 457 p.
- Fernando, C.H. and M. Halwart. 2000. Possibilities for the integration of fish farming into irrigation systems. *Fisheries Management and Ecology* 7: 45-54.
- Willmann, R., M. Halwart and U. Barg. 1998. Integrating fisheries and agriculture to enhance fish production and food security. *The FAO Aquaculture Newsletter* 20: 4-9.

Prepared by:
Matthias Halwart and C. H. Fernando

Rice and Fish Culture in Seasonally Flooded Ecosystems

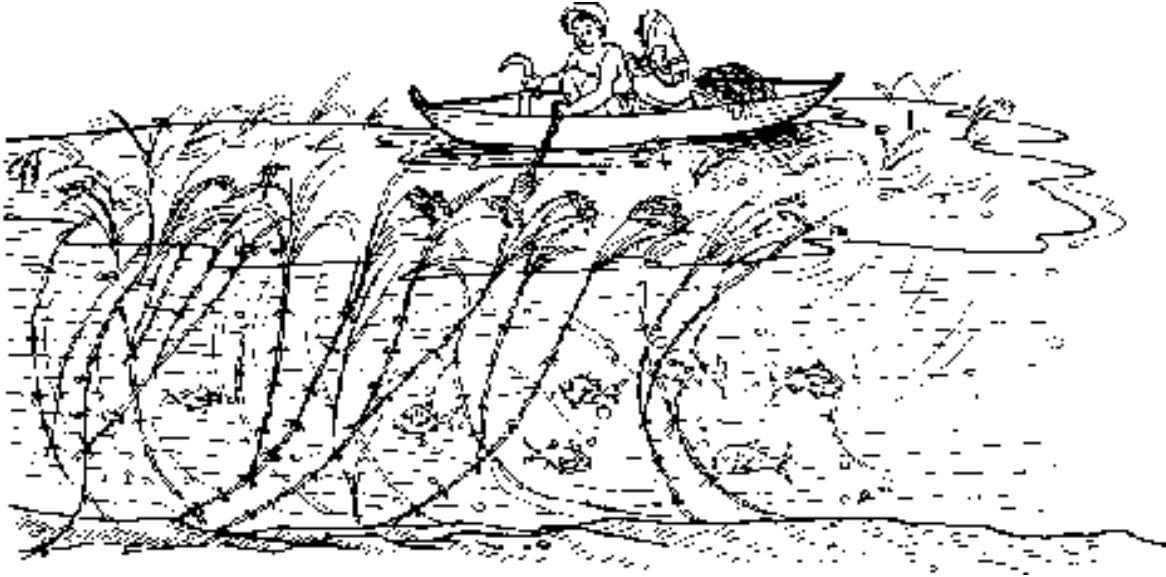

Farming in a flood-prone environment

Seasonally flooded ecosystems play an important role in the livelihoods of people in Asia. These areas are also the densely populated valleys and deltas of the major rivers: the Ganges, the Brahmaputra, the Godavari, the Irrawaddy, the Chao Phraya and the Mekong. In these floodplains, farmers have traditionally grown rice in a variety of systems. The main system, in which rice was farmed in the post-flood season in shallow-flooded areas (5 to 50 cm), was to sow rice into the moist areas after water had just receded and to grow the crop into the dry season. A different set of systems was used in the deep-flooded areas (50 cm to 6 m) where farmers grew either rice varieties that were submergence-tolerant (up to 1 m for four weeks), or grew floating rice varieties in areas flooded at greater depths (up to 6 m) for longer durations. In these systems, seeds were sown into the dry or already moist soil just before the rainy season and the rice harvested at the end of that season.

These floodplain areas also play a very important role in the supply of living aquatic resources (LARs) during the flood season. During this important time of the year, people engage in a wide range of fishing activities in these flooded areas, harvesting fish, crustaceans, mollusks, frogs, turtles, insects, etc. The harvests play an important seasonal role in the diet of rural poor as the highly nutritious foods make up for the nutrient deficiency during the preceding dry season. They are also a major source of income, especially for the landless, who often rely on these activities for their entire annual income and therefore are highly dependent on the existence of, and their access to, these resources.

In the last few decades, flood-prone ecosystems in Asia have undergone dramatic

changes due to the construction of Flood Control, Drainage and Irrigation (FCDI) systems. Flood patterns have changed and the abundance of LARs have been reduced. Through increased availability of irrigation, a second crop of rice is now grown in the dry season. As these are high-yielding rice varieties and their cultivation periods last almost to the onset of the floods, farmers in many areas who were previously culturing rice during the flood season have abandoned this practice, leaving the areas fallow. Rice yields from the flood season are low as improved varieties are not available.

An opportunity for increased production is the cultivation of fish in the deeper flooded areas. Two culture systems can be distinguished: (1) sequential culture of dry season rice followed by stocked fish only during the flooded season (i.e., without rice) in an enclosed area (e.g., as in a fish pen); (2) simultaneous culture of stocked fish and submergence-tolerant rice varieties or floating rice varieties. On an annual basis, these approaches offer an overall improvement of agricultural production from a given area of land through a diversification of technologies. In the flooded area, individual land holdings are not visible. Therefore, activities require a group approach by the rural community. These include the landless who have traditionally accessed the flooded areas for fishing, but would lose this essential resource if they were denied access because the areas were stocked with fish (i.e., which have become a commodity, aside from the existing "wild" fish).

Basic principle

After the cultivation of dry season rice, when fields are flooded to a depth at which individual ricefield boundaries (i.e., bunds) cannot be distinguished, floods form a water body for 4 to 6 months. The farm is usually left as flooded fallow, but it can be used to grow deepwater rice and/or fish. Given adequate topographic site characteristics (i.e., a lowland area of rice plots almost enclosed by natural elevated lands, raised homesteads, dams for roads, train tracks, canals, etc.), ideally it should be such that only a small bottleneck-type opening is left to let floodwaters in, it is possible to close the bottleneck with a fence and stock the enclosed water body with fish. Deepwater rice can be grown as a substitute to the second dry season rice crop if the field is left fallow during the dry season. It is sown into the dry soil just before the flood season.

Criteria of managed areas

The areas considered for concurrent or sequential rice-fish culture are flooded annually and have shallow (30 to 80 cm) to medium (80 to 150 cm) flooding depths.

Site selection is based on the following criteria:

- adequate size, i.e., 2 to 10 ha;
- natural or existing artificially elevated lands (e.g., homesteads, dams, etc.)

- enclose the area on three sides to allow fencing off;
- stakeholders of a water body, including landowners, leaseholders, landless fishers (who may have customary rights to fish in the flooded waterbody but are denied access during the dry season) can be involved in a shared management arrangement; and
 - groups are not too large (<30 persons) to avoid organizational problems.

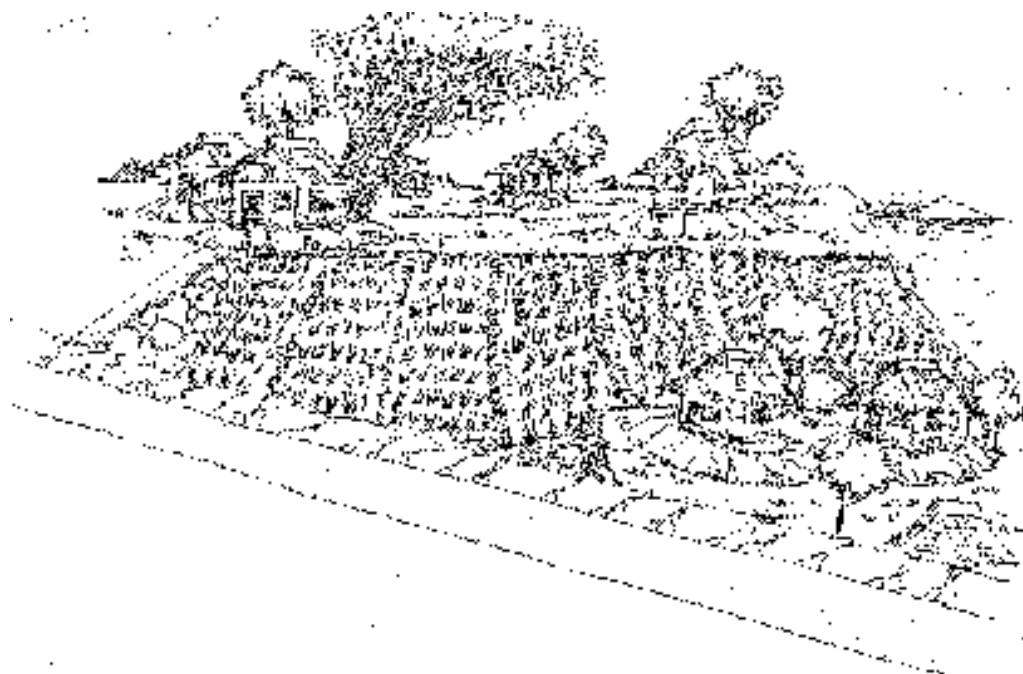

Dry rice field

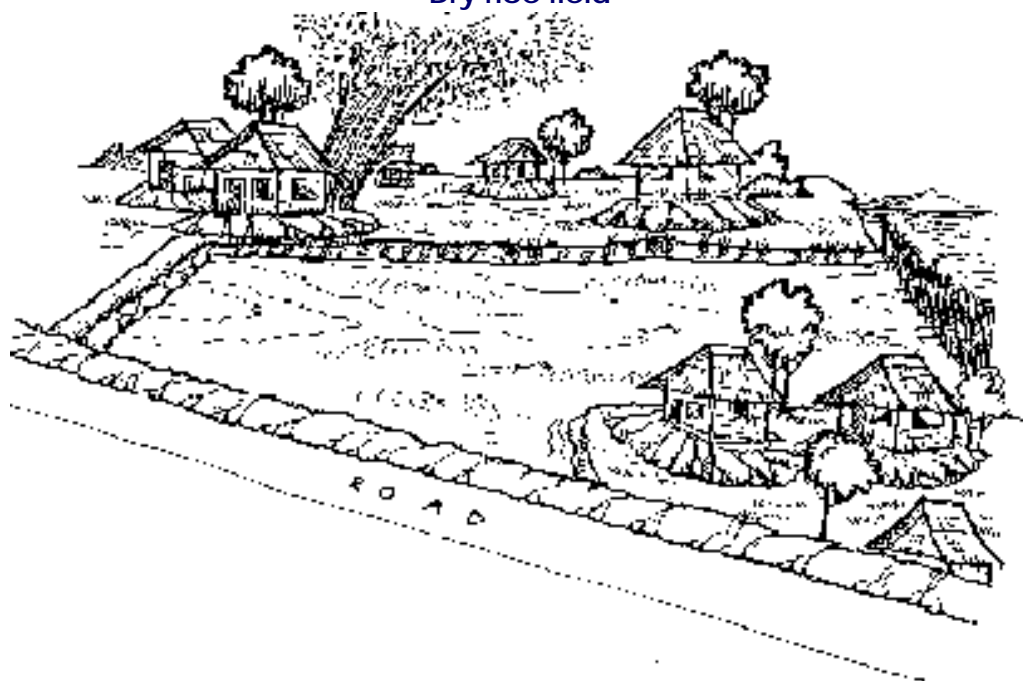

Flooded field stocked with fish

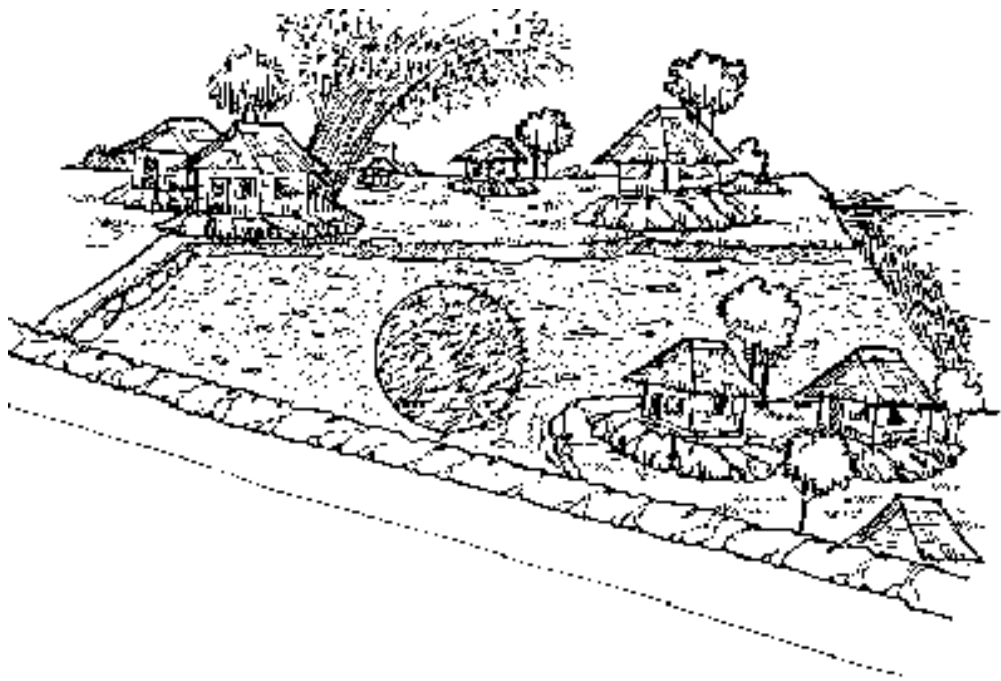

Flooded field with deep water rice stocked with fish

Comparison of dry season rice field (upper drawing of bird's-eye view of village) with two options for cultivation in flooded fields: 1. Flooded field stocked with fish only (middle drawing); 2. Flooded field planted with deepwater/ floating rice stocked with fish (lower drawing).

Group formation, cooperation and sharing arrangements

Groups are usually composed of around 20 households each, consisting of landowners, fishers and landless laborers. Landowners may be participating or non-participating. Non-participating landowners receive a share by just providing their land, but are otherwise not active in group activities. Actively participating landowners in the group activities receive an additional share for their role as group members aside from what they already receive as landowners.

Farmers groups will have to negotiate and agree on cooperative sharing arrangements, rules, technical details and schedules of operation. These may be influenced by other existing agreements and ongoing conflicts.

Sharing arrangements include rules of access, duties and rights of participating (active) and non-participating (passive) members; investors of land (granting use rights) versus investors of labor (landless with customary access rights to fishing in season), etc.

The group covers all costs from the proceeds of rice and/or fish sales. A common arrangement in Bangladesh for sharing the remaining returns is 40% for landowners, and 60% for group members. Landowners are usually keen on joining the activity as they receive returns from land that is usually fallow during the flood season.

Enclosure

The enclosure should be designed and built by the cooperating farmers. It is usually a fence made of locally available materials like bamboo, reed and wood, but can also be made of netting material, which lasts longer if available locally at affordable cost.

In some locations, natural saucer-shaped depressions not connected to another open water body or river provide ideal situations for fish culture. The fish could not escape and

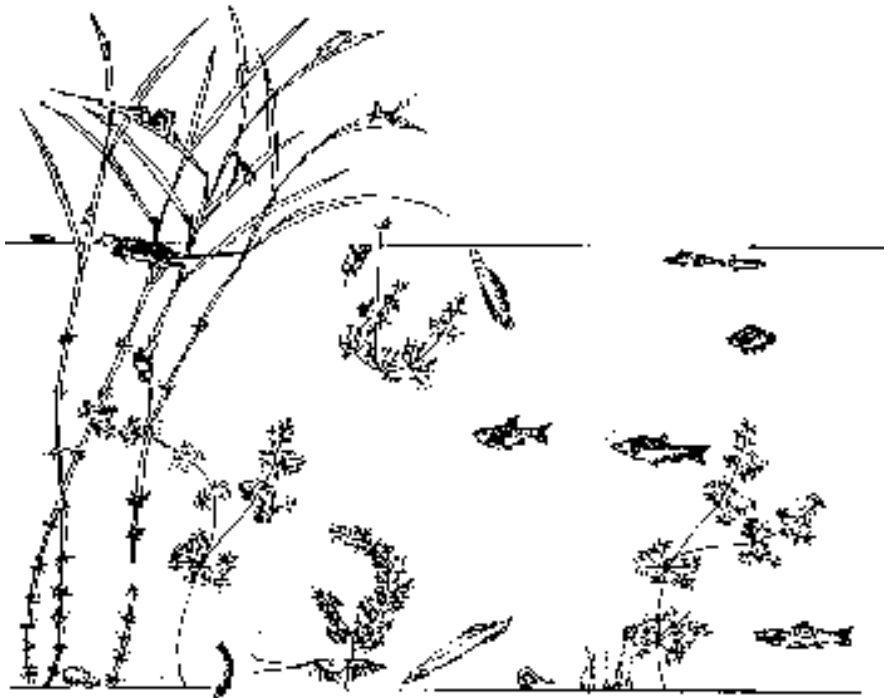

construction costs are eliminated. Additionally, farmers get the chance to implement different rice cultivation strategies in the shallow and deeper parts of the water body.

Investments

The groups will have to invest in a fence or dike (where necessary), fingerlings, labor (fence or dike construction and maintenance, feeding, harvesting) to successfully master the activity.

Sequential dry season rice and flood season fish culture

If farmers decide to maintain two crops of high-yielding rice varieties per year and do not want to substitute the second crop for deepwater rice, specifically stocked fish species can be grown within the enclosure.

Concurrent deepwater rice and fish

After transplanting rice, bigger fingerlings can be stocked into the ricefields and reared until the water dries up, usually after rice harvest. Bigger-sized fingerlings are costly, but the expenses can be recovered by increased growth and survival (i.e., less escapes and losses to fish predators) and ensuing greater returns. The availability of larger fingerlings in adequate sizes and quantities can pose a problem and should be planned for, e.g., through fry-to-fingerling rearing in rice fields in the preceding dry season, or in small ponds in the deepest parts of the enclosed area.

Deepwater rice technologies (for concurrent rice-fish culture)

- **Rice varieties**

Use taller rice varieties, characterized by (1) more than 160 cm total plant height at harvest time, and (2) a taller seedling height.

- **Fertilization of deepwater rice**

Fertilizers should be given but only in basal dose form for deepwater rice.

- **Pesticides**

No pesticides should be applied.

Fish technologies

Species combinations

Fast growing species like silver carp, common carp, rohu, silver barb and Nile tilapia are recommended. Other species chosen by farmers for stocking are grass carp, catla and snakeskin gourami.

Fry and fingerlings of naturally occurring fish species can enter into the enclosed areas at the time the flood rises. The indigenous or "wild" species can grow and reproduce for harvest by small-scale fishers.

Stocking density

Stock at 2,000 to 4,000 per hectare, depending on the size of fingerlings (around 5 to 15 g) at stocking.

Feeding of fish

Fish can feed on natural food and by-products available in the ricefield, both in concurrent culture and in sequential culture without rice. However, when growth is slow, supplemental feed (e.g., rice bran) may be given at a later stage.

Additional technical options

With a short-duration rice crop, an intercrop of soy bean, maize, green leafy vegetables, etc., can be grown before the flood.

Benefits

Fish yield. 500-1200 kg per hectare.

Rice yield. The basic rice yield is about 10 t/ha/y for two crops. The introduction of fish does not result in rice yield decrease. In fact, it has been shown to increase marginally by about 500-1000 kg/ha/y.

Increase in profitability. US\$300-400/ha/y, or an increase of 30 to 40% over the previous profitability of US\$1000.

Impact on landless laborers. Income and per-capita fish consumption increased substantially.

Role of external support

To start this type activity through a demonstration in a given area, the initial input of local service institutions, NGOs or other organizations is necessary to provide local experience and facilitate site selection, group formation, decision on technical issues and other processes mentioned below.

From experience, as a result of the demonstration, other groups establish themselves without external inputs or stimulus and establish their own sharing arrangements. Second-generation groups arrange for their own funding and other logistical requirements, such as fingerling purchase and transport, while first-generation groups tend to remain dependent for funding and other support on the service institution that helped establish them.

Site selection survey should be conducted together with a group to enhance comprehension. The idea can be raised during discussions with individuals, then with groups of landowners, landless, etc. Meetings to facilitate the presentation of the idea to a larger group, including discussions towards consensus, establishment of a "management committee", and to the formulation of a sharing arrangement, should be conducted. External groups should act as credible provider of technology and witness and arbitrator. It is necessary to assist groups in the selection of fish species and rice varieties, stocking densities and sourcing of fingerlings and to provide guidance on the proper transport and stocking method to ensure high survival. Repeated visits are necessary to ensure smooth interactions among group members and to facilitate meetings to solve/settle problems and brewing conflicts. Farmers/actors who will do the work (fence construction, stocking, feeding) should be trained and the group should be assisted in financial accounting, harvest methods and equipment (nets), marketing of harvest and the actual sharing of the yield both in terms of fish and cash.

Startup loans

The initial investment in the fence can be considerable and groups might hesitate to adopt a new technology with risks involved, especially when its effectiveness has not yet been demonstrated to them. Farmer groups may be wary of the investment in fingerlings for stocked fish. Startup loans, to be repaid upon harvest, have eased the adoption process and given the groups confidence to embark on the activity.

Sustainability

Fence material may decompose after one season and has to be replaced at high cost sometimes. Socioeconomic factors include setting aside part of the returns for reinvestment the following year on a fence (mending, renewal, etc.) and for restocking (fish, rice). Social factors include group enforcement of rules and elements of the agreement.

Factors influencing adoption

- **Socioeconomics**

Homogeneity of households in a group is a positive factor for adoption of technology. Heterogeneity of households within a group will create problems for the operation, since complex social issues and factors influence success. With larger groups, there may be economy of scale but also an increased risk of internal conflict.

- **Biophysical**

factors

Fluctuations in the onset and duration of the rainy season, as well as average flooding depth, affect rice-fish culture. With longer duration rice -- or with floods rising before rice is harvested -- farmers cannot grow an intercrop or transplant deepwater rice. Harvesting rice with rising water can be difficult and laborious. With the water rising, deepwater rice can only be broadcast. It is more straightforward to undertake rice-fish culture in a relatively flood-controlled environment.

- **Biotechnical factors**

Availability of fingerlings of species (desired by farmers) in appropriate sizes and quantities for stocking can pose problems and should be planned for.

- **Institutional issues**

Presence of, or possibility of forming rural organizations and/or farmers groups, is essential.

Potential areas for adoption

Medium-flooded areas of Bangladesh, Mekong Delta of Vietnam, and eastern India can be brought under this technology. It seems possible to introduce the technology into similar environments in Africa and Latin America, depending on further on-farm testing.

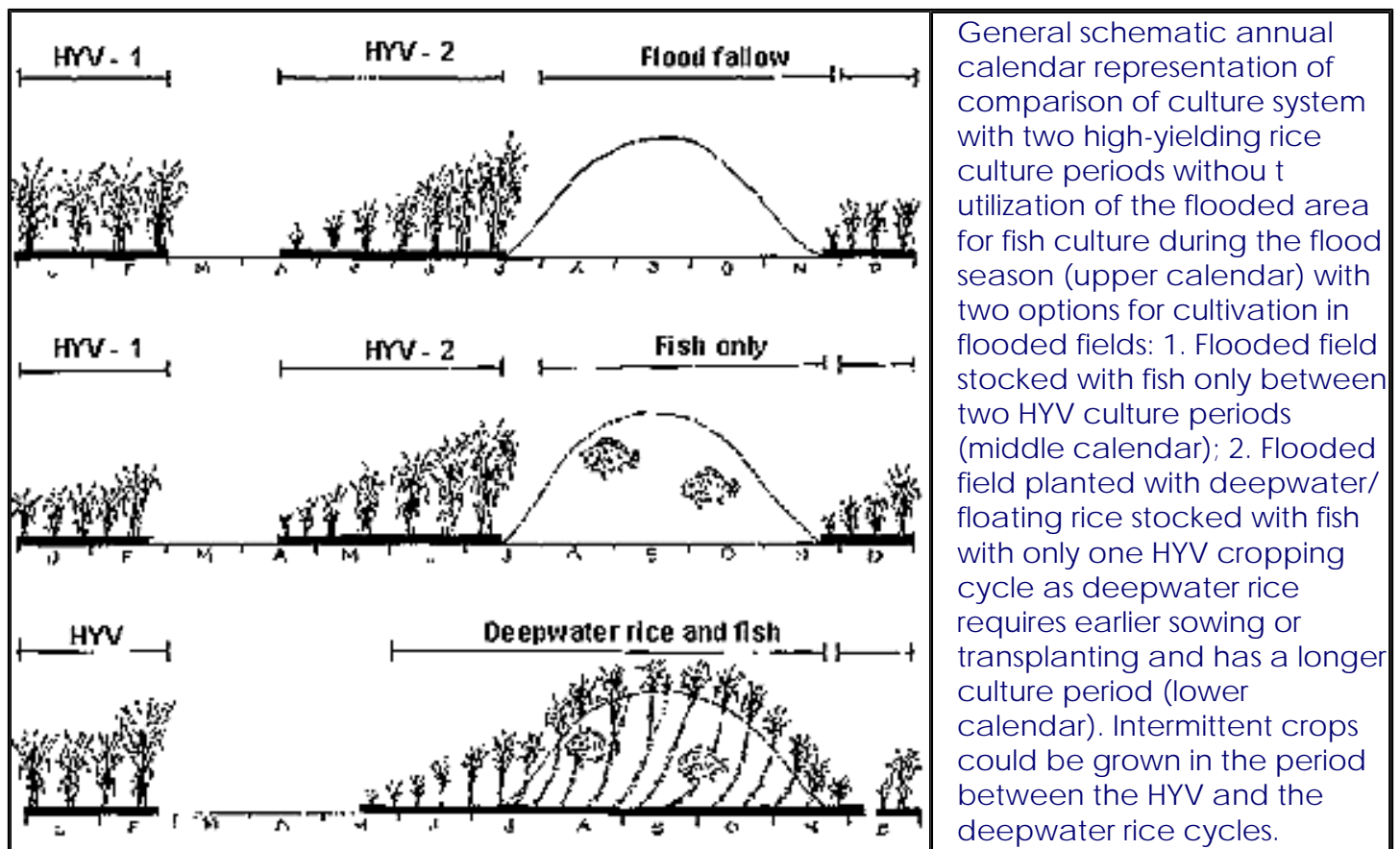

General schematic annual calendar representation of comparison of culture system with two high-yielding rice culture periods without utilization of the flooded area for fish culture during the flood season (upper calendar) with two options for cultivation in flooded fields: 1. Flooded field stocked with fish only between two HYV culture periods (middle calendar); 2. Flooded field planted with deepwater/floating rice stocked with fish with only one HYV cropping cycle as deepwater rice requires earlier sowing or transplanting and has a longer culture period (lower calendar). Intermittent crops could be grown in the period between the HYV and the deepwater rice cycles.

Validation status

Three years of field trials with two communities in the Red River Delta, three communities in the Mekong Delta, and a total of nine communities in Bangladesh.

This technology has been adopted in provinces in northern Vietnam by local governments and the Department of Science and Technology with considerable investment and is being disseminated among farmers.

In Bangladesh, the country-wide operating NGO – Proshika – has adopted the technology as part of its rural development program. The Department of Agriculture

Extension will implement the technology on a wider scale in one of its projects (ADIP/DAE) funded by IFAD.

References

Catling, D. 1992. Rice in Deep Water. International Rice Research Institute, Manila, Philippines. 542 p.

Hargreaves, T.R. 1975a. Improved Rice Varieties Needed for World's Deep Water regions. The IRRI Reporter 3/75.

Hargreaves, T.R. 1975b. Characteristics and Culture of Floating Rice. The IRRI Reporter 3/75.

IIRR and ICLARM. 1992. Integrated Agriculture-aquaculture Technology Information Kit. International Institute of Rural Reconstruction, Silang, Cavite, Philippines, and ICLARM.

Prepared by:

Mark Prein and Madan Mohan Dey

Increasing Wild Fish Harvests by Enhancing Rice Field Habitats

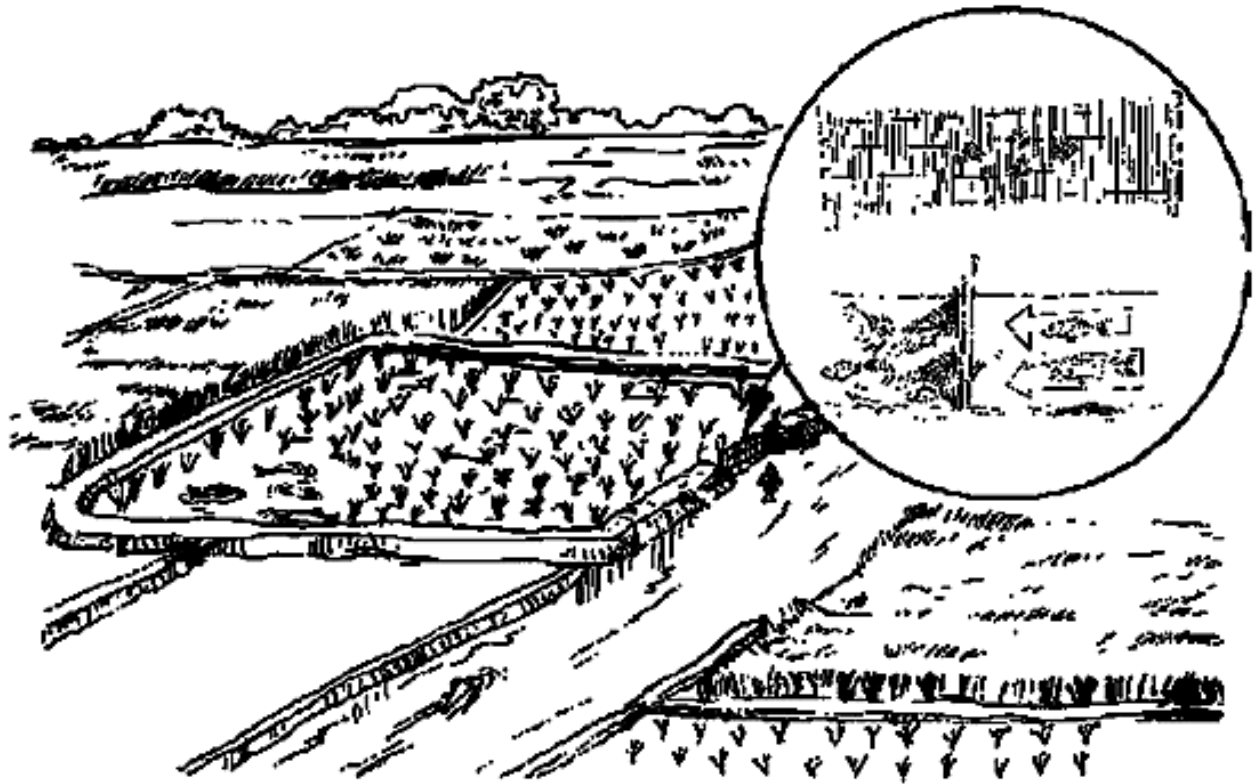

Aside from producing the carbohydrate staple, the rice paddies of Bangladesh are also known as reliable sources of fish. Large quantities of fish enter the flooded paddies during the rainy season, spawn and grow there. In the past, this was possible without any active management as the rice fields were full of indigenous small fish. Today, however, the quantity and diversity of wild species have decreased significantly. If this downtrend continues the fishes in the rice fields and flood plains may completely disappear. This will have dire consequences for poor people who depend largely on the rice fields for fish, a major source of animal protein in their diet.

Taking this into consideration, the Aquaculture Unit of New Options for Pest Management (NOPEST) of CARE Bangladesh (funded by European Union) conducted a small-scale survey in its project area in Mymensingh and Comilla districts to:

- identify the naturally available fish species in rice fields;
- identify their annual migration patterns (how/when they arrive in the rice fields);
- examine those factors leading to a decrease in the amount wild fish in the rice fields;
- review methods of improving water management at the farming community

level, which can restore or improve the fish habitat.

Wild fish yield and diversity in rice fields

In the study areas, it was found that wild fish production without any intervention was about 60-85 kg/ha during *amon* (a rice-growing season in Bangladesh lasting from July until December), which is a significant amount.

However, fish production in the fields under rice and fish cultivation averages 125 kg/ha and some farmers can harvest up to 200 kg/ha within a five-month cultivation period. Higher yields are due to the location of the plots near lowland water-bodies (beel), and the use of ingenious traditional equipment in dikes. The dikes allow fish to enter the plot but prevent them from swimming out.

Species diversity fluctuates from area to area and even plot to plot because of the various distances of the fields to a beel and the number of connections between them. As the distance to the beel decreases, fish quantity and diversity increases. Good beel connections facilitate wild fish migration. Longer periods of inundation also result in bigger catches as higher amounts of rainfall and longer monsoon periods contribute to the spread of indigenous wild species. Early season rains are important but the consistency of rainfall is more important as it is during dry periods that the diversity and the number of fish decrease.

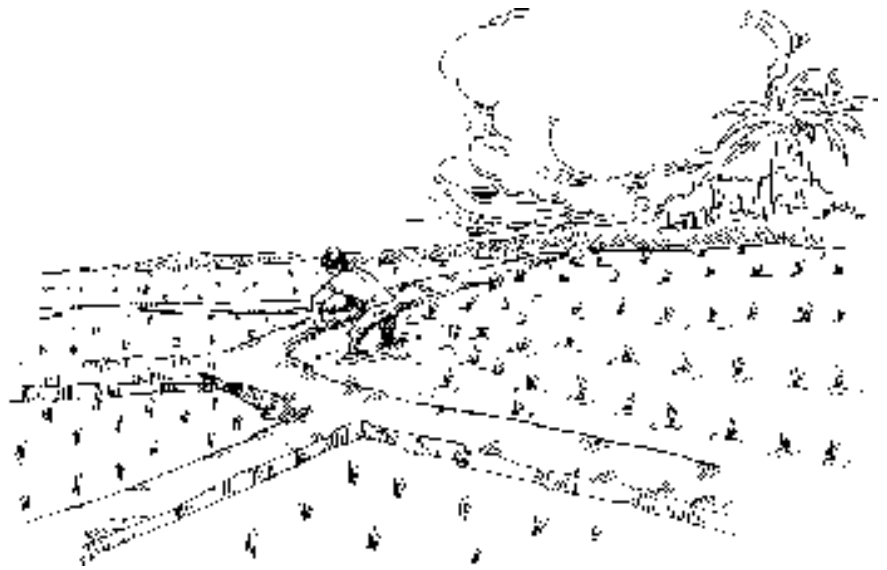

Caution!



Some Organochlorine pesticides are commonly used in Bangladesh. A few drops of Endrin or Aldrin are enough to kill all fish in a field.

Fluctuations in species diversity are also due to pesticide applications. Fields containing pesticide residues make less favorable habitats for fish, resulting in lower yields and fewer species.

Species mentioned in Table 1 are perhaps the only ones now generally found in rice fields of Mymensingh and Comilla. Some other species (including major carp) were found but not in

significant numbers.

Table 1. Common and scientific names of the fish species in the study areas, their frequency, characteristics and their sensitivity to pollution

Common local name	Scientific name	Frequency	Characteristics (all species bred during moonsoon)	Sensitivity to pollution
Kuche	<i>Monopterusuchia</i>	+	Carnivorous	-
Darkina	<i>Rasbora daniconius</i>	++++	Omnivorous	-
Chale puti	<i>Puntius chola</i>	+++	Plankton feeder	---
Taki	<i>Channa punctatus</i>	+++	Carnivorous	-
Lal kholisha	<i>Colisa fasciata</i>	+++	Omnivorous	--
Koi	<i>Anabas testudineus</i>	++	Carnivorous	--
Local chingi		++	Detritus feeder	--
Mola	<i>Amblyphyrangodon mola</i>	++	Plankton feeder	----
Kachiki	<i>Corica soborna</i>	++	Omnivorous	---
Tara bain	<i>Mastocembelus aculeatus</i>	++	Bottom feeder	--
Tengra	<i>Mystus vittatus</i>	+	Carnivorous	---
Shing	<i>Heteropneustes fossilis</i>	+	Carnivorous	-
Gasua	<i>Channa orientalis</i>	+	Carnivorous	-
Shol	<i>Channa striata</i>	+	Carnivorous	-
Magur	<i>Clarias batrachus</i>	+	Carnivorous	-
Gutum	<i>Lepidocephalus spp.</i>	+	Omnivorous	--

Legend

+ = Least frequent - = Least sensitive
 +++++ = Most frequent ---- = Most sensitive

Role of the rice field in the life cycle of wild fish

Wild fish enter and thrive in the wet paddy environment so rice-field fishery is possible. Traditionally, no management inputs were necessary for these fields. However, farmers still know how the fish came to be in their fields.

According to the farmers

- Wild fish come from nearby rivers, canals, and lowland water bodies when the fish enter the fields through channels, drains, or ground surface runoffs during the rainy season (May-August). In most cases, beels are found to be the source of wild stock in the paddies.
- Water runs off towards the beel areas and the rice paddies become inundated and merge with the beels. A single shallow sheet of water is formed as the dikes are flooded, which serve as the spawning grounds for wild fishes.
- Broods of wild fishes move towards the upland areas where the water is shallower. There, the fish spawn and lay their eggs, the rice field being an

integral part of their life cycle. Rice fields also act as nursery grounds providing a favorable habitat for spawn and fry. This is reflected in farmer's comments such as "In the monsoon season when we catch fish from the canals or drains, the fishes' bellies are full of eggs, while at the end of monsoon the harvested fish are without eggs and small in size".

- After the monsoon, when the water flow stops, the migrant fish and their juveniles try to return to the beels. Some of them make it back to the beels and continue their life cycle but most are unable to escape from the rice fields because of the dikes and those that remain are eventually trapped and caught.

Factors responsible for the decrease in fish stock

● Loss of habitat and sedimentation

Expanding network of flood control, irrigation structures and roads built over the last twenty years are interfering with the cycle of fish regeneration. These structures block migration pathways and degrade natural spawning and feeding grounds.

Dying vegetation in the marshy lowland water and the annual accumulation of soil, nutrients and debris carried by the monsoon rainwater through the canals towards the beel lead to siltation and sedimentation. These deposits reduce the surface area, depth and water carrying capacity of both the beels and canals.

● Drying out

During the dry season, majority of these water bodies dry out and as a result no fish are left to spawn in the monsoon. As a result, less brood fish can migrate to the upland rice field areas to spawn.

● Water pollution

Household wastes and fertilizers in the lowland water bodies, come from the runoff of agricultural land during the monsoon season. This is a problem in the beels (permanent habitat of wild brood fishes) during the dry season when the water level is at a minimum resulting in the growth of plants and algae. These plants cause oxygen depletion resulting in frequent suffocation of fish and oxygen is further depleted through the decaying process of decomposers.

● Introduction of high yielding varieties of rice

Farmers have increased their use of pesticides since they began to cultivate high-

yielding rice varieties. They perceive these varieties require more pesticide and chemical fertilizers, hence there is a continuous increase of pesticide and other chemical residues in the beel through rice field run off. This has an adverse impact on the reproductive system of fish among others. These pesticide residues remain in the water body or rice fields year after year, having a cumulative negative impact on aquatic life. There has been evidence from studies on rice field fisheries in Malaysia that prior to the introduction of high yielding varieties, capture production averaged 135 kg/ha in the range 10 to 400 kg/ha. More recently however, based on records of capture production in Asian countries, the range is from 1.5 to 84 kg/ha.

- **Disease**

Indigenous wild fish species such as snake headed fish, local cat fishes, *Puntius* spp., *Anabas* spp., etc., are more susceptible to ulcerative disease. In the past ten years, these species have been greatly reduced. The disease causing factors have not been diagnosed yet, but may have spread into Bangladesh from neighboring countries. In some instances, fish develop immunity to certain diseases and this may well happen in Bangladesh over the years.

I Over fishing

In monsoon, during spawning and the migration towards rice fields, traps, small mesh sized drag nets and current nets are placed in locations close to each other throughout the narrow waterways. There is very little chance of any fish escaping through these traps to spawn. With increasing human population, more people are involved in wild fish harvest with a greater use of various types of equipment and nets. This, combined with traditional seasonal fishing, leads to an intensification of fishing thus reducing the wild fish population in the rice fields. Many rice fish projects actually do not recommend that wild fish should be present in the rice field together with cultured fish. This is also responsible for the reduction of wild fish stock.

Interventions to restore and improve fish habitat

- **Community responsibility**

The Bangladesh government has plans to implement huge flood control and irrigation projects and construct more roads and highways. If these were planned well, the effect on the life cycle and migration patterns of wild fish may be minimal. Through proper management and maintenance of the drains, brood fish habitats would not be lost. As these interventions affect the community, they should be involved to ensure good management. These communities should be responsible for ensuring that waterways are dug out regularly and dead canals are re-excavated.



- **Integrated pest management (IPM)**

IPM may improve fish habitats over time, leading to an increase in fish populations. Intervention should consider that changes to the overall crop management will have a profound impact on the rice ecology. A healthier rice ecosystem will offer wild fishes a sound environment to breed and live in.

- **Use of dikes**

Some farmers construct dikes in the lowest portion of the rice field. During drought these provide shelter and after draining the field for harvest, fish can easily be collected from there. These dikes normally surround the fields so by raising the dikes, fields are protected from flooding, which removes fish from the field. Farmers fit traps

Using traps in dikes allows wild fish inside the ricefield and prevents them from escaping.

in the dikes in monsoon season that allow fish to enter the field from the open water but prevent them from swimming out from the rice field. The objective of this system is to collect wild broods, allowing them to grow in the rice fields until the dry season.

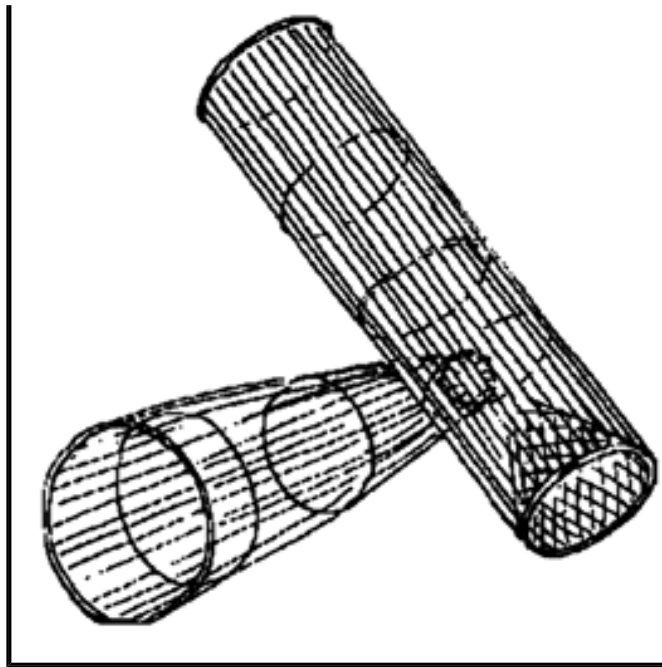

Farmers also use branches of "shewra" tree that attract the fish to take shelter within the dikes. This is an indigenous management technique leading to yield rates that are high even in comparison to rice-fish cultivation production. After harvesting rice in November and December, the fish harvest can continue until January as the branches provide a refuge for the fish.

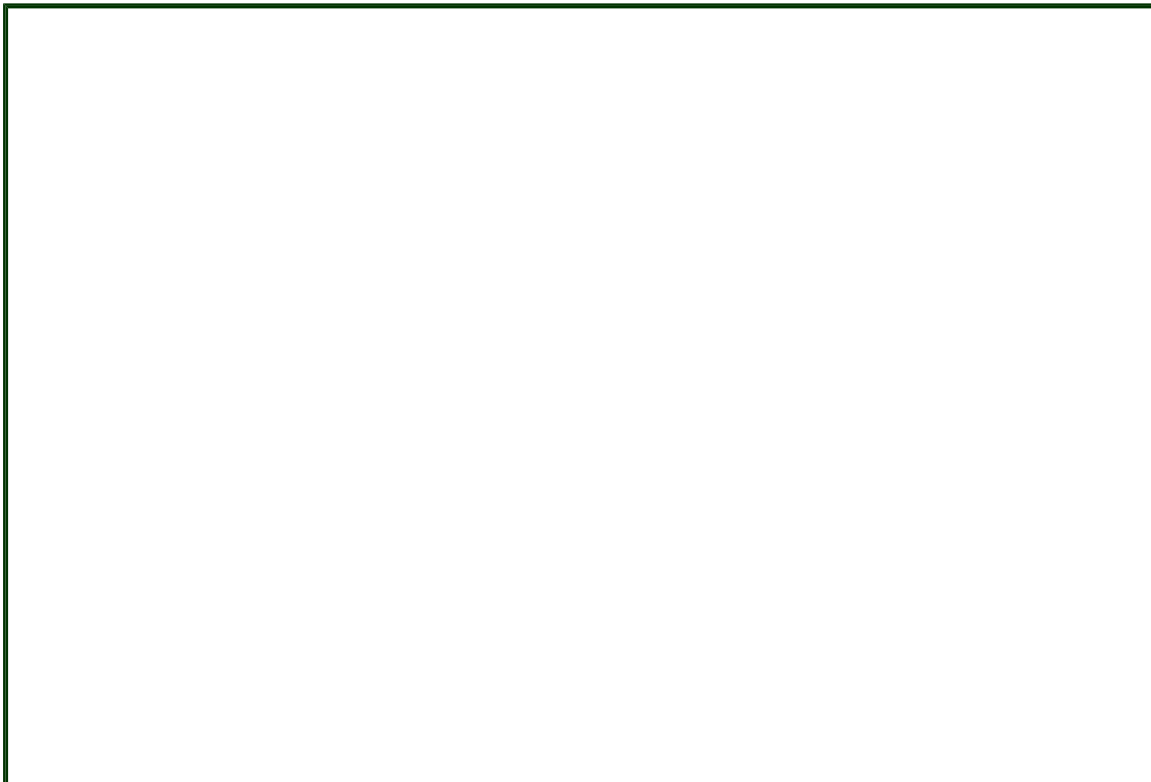

Most development organizations avoid working in lowland areas that are remote and susceptible to flood, considering it unfeasible in terms of project outputs. Hence, people of these lowland areas are deprived of all kinds of development activities and they unwittingly destroy their wetlands.

Increased understanding of the rice field ecology would increase productivity and indigenous wild fish numbers during the monsoon season.

Adopting this approach, fish harvest could go up to 250 kg/ha/crop in amon with little effort (confirmed from trials). In rice fields where wild fish are allowed to enter through the bana (bamboo net), even up to 400 kg/ha can be harvested. Rice yield and stocked exotic fish production were not affected unlike rice fields completely surrounded by massive dikes.



Conclusion

The wetlands of Bangladesh should be incorporated into small-scale development programs to create new opportunities for deprived farmers. When they are empowered to learn about rice field ecology and water management, they will be able to make better decisions on wild fish conservation.

Reference

Soong, M. K. 1950. Fishes of the Malayan Paddy Fields III: Keki Catfishes. Malay, Nat. J. S. p 88-91.

Prepared by:

A. K. M. Reshad and Harald van der Hoek

Polyculture Systems: Principles and Basic Considerations



Polyculture is a strategy to utilize the different food niches in an aquatic system and harness maximum possible amounts of nutrients and energy in the form of fish. Aimed at harvesting the productivity at different trophic levels, the approach incorporates different fish species, based on the availability of food and the feeding habits of the species.

This paper focuses on freshwater systems as there are no established polyculture practices in brackish waters and marine systems.



Food chains in a pond system

The polyculture systems put considerable emphasis on the natural productivity of the water bodies. Photosynthetic and heterotrophic food chains operate in the process of energy transfer from solar radiation to the fish biomass. Producers, consumers and decomposers are the key players in these chains.

In a photosynthetic food chain, the primary producers (phytoplankton and bacterioplankton) synthesize organic matter and utilize inorganic nutrients in the presence of solar radiation. These are grazed by the zooplankters (primary consumer level) which, in turn, are preyed upon by the higher level consumers like fish and

shellfish.

The heterotrophic food chain is characterized by intense activity of the decomposers. These decomposers degrade organic matter into simpler compounds that are further mineralized into inorganic nutrients. The detritus resulting from the process becomes an important food source for fish and shellfish. This also reduces the number of steps in the energy transfer process, enabling higher productivity levels.

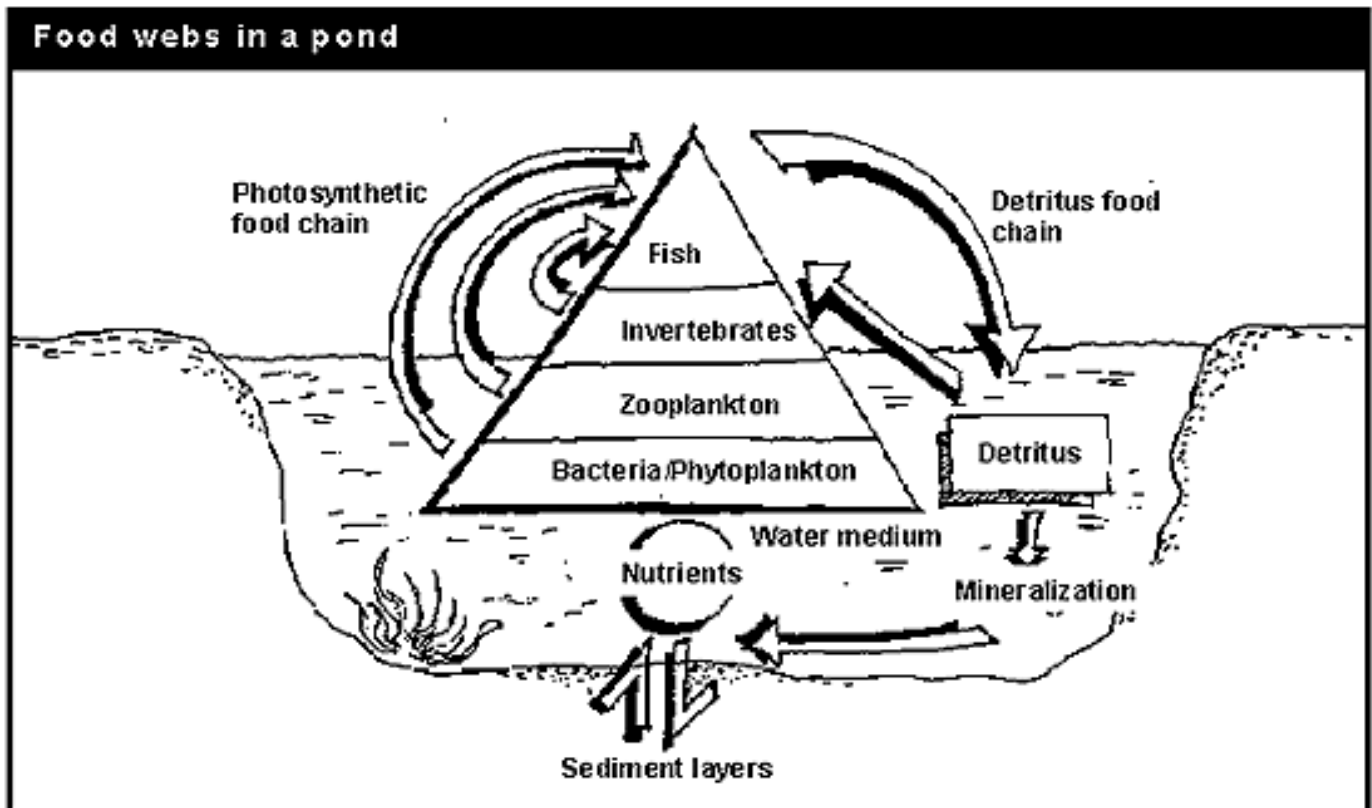

Components of polyculture

Cyprinids, referred to as carps, have been the mainstay of polyculture practices all over the world. The feeding habits of the carps, herbivorous and detritivorous, ensure optimal utilization of the resources in the aquatic systems (in terms of the two food chains previously discussed). Asian aquaculture is dominated by carp polyculture, on account of the fish's filter feeding habit, differing strata of feeding in the water body and compatibility with each other. Carps are grouped into three categories, major, medium and minor, based on growth rates. The fish attain individual sizes of 1,000-1,500 g in a year's time. Compatibility, mainly with regard to feeding habits, schooling and dwelling habits, are the key criteria for the incorporation of new species.

Typical mixed farming systems

Thailand

- Silver barb
- Tilapia
- Common carp/
mrigal



Vietnam

- Silver barb – Grass carp
Giant gourami
- Tilapia – Kissing gourami
Common carp

The typical South Asian polyculture employs a combination of major carps:

- Silver carp (*Hypophthalmichthys molitrix*) largely filter feeds on phytoplankton with its fine gill rakers.
 - Grass carp (*Ctenopharyngodon idella*) grows on macrovegetation and sustains the growth of a number of other species which feed on its feces containing partially digested plant material.
 - Common carp (*Cyprinus carpio* var. *communis*, scale carp), an omnivore, is able to use a variety of food niches in the pond system, like decomposing organic matter and plankton.
- With their different feeding habits, three Indian major carps, catla (*Catla catla*), rohu (*Labeo rohita*) and mrigal (*Cirrhinus mrigala*) fit ideally into a polyculture system. Catla is a surface feeder, rohu dwells in the column waters and mrigal is a bottom feeder.
 - Silver barb (*Barbodes gonionotus*), Kalbasu (*Labeo calbasu*), *Puntius pulchellus*, *Cirrhinus cirrhosa* and freshwater prawns (*Macrobrachium* spp.) are also included in polyculture systems, as substitutes for some of the components or for adding value.

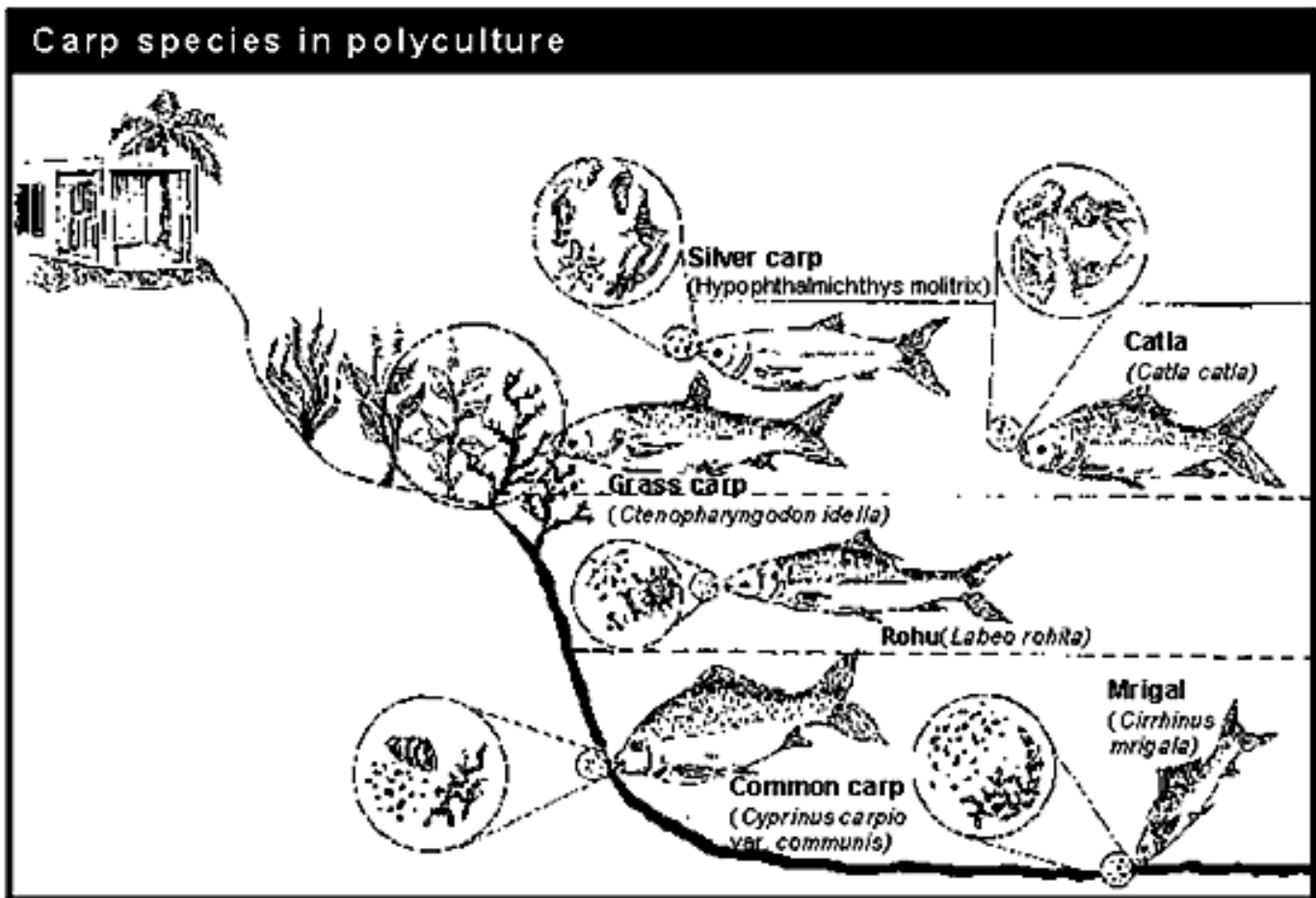

Culture systems

Polyculture in ponds

Polyculture technology provides a scientific basis for the optimal use of resources. With combinations of three Indian major carps or six species at densities ranging from 4,000-10,000 fingerlings/ha, production levels of 2,000-10,000 kg/ha/year have been recorded.

Intensification of culture practices comes in the form of supplementary feeding. This includes the provision of a mixture of rice bran or wheat bran and oilcake in equal proportions of three to five percent of fish biomass on a daily basis. Every month, the feeding proportion can be increased in proportion to the growth of the fish. Water replacement of up to 10% of the volume of the pond is another measure to enhance production.

Management measures

- Pond preparation in terms of clearing the pond of aquatic vegetation and fish predators.
- Fertilization at a rate of 10 tons cowdung or 2 tons poultry manure, or 5 tons of pig dung per ha per year at bimonthly intervals.
- Urea at a rate of 100 kg nitrogen/ha/year, i.e., 212 kg urea in a hectare of water in a year.
- Superphosphate at a rate of 50 kg phosphorus/ha/year, i.e., 325 kg single super phosphate in a hectare of water area in a year.
- Supplementary feeding of rice bran, wheat bran and oilcake.



The practices allow a great deal of flexibility in terms of scale of operations, species, densities, fertilizers and feed ingredients, depending on the local resources, consumer demand of species, etc. Many farmers have employed two to three species like rohu and catla, feeding at frequent intervals and high levels of water replenishment. This has led to high levels of fish production, 10-12 tons/ha/year, as in Andhra Pradesh, a state on the east coast of India. Fish from this region are supplied to several parts of India and neighboring countries like Bangladesh, Nepal and Bhutan.

Integrated fish farming

Integrated fish farming refers to a combination of practices, incorporating the recycling of wastes and resources from one farming system to the other, to optimize production and achieve maximal biomass harvest while maintaining eco-harmony. Agriculture and livestock by-products are recycled for use in fish culture systems. Fish-livestock farming, combined with crop raising, has been well demonstrated in Chinese small-scale farming systems.

Rice-fish system, horticulture-fish farming, integration of fish farming with livestock (i.e., cattle, poultry, ducks, pigs), mushroom cultivation, sericulture, etc. have not only allowed the recycling of organic wastes as manurial resources in aquaculture, but also helped greatly in environmental upkeep.

Polyculture of carps has enabled the use of different food compartments in these systems, as well as through coprophagy of some of the species. A cattle head or 3-4 pigs or 50-60 poultry birds or 20-30 ducks per 0.1 ha area of pond are suggested for integration with fish farming to meet the nutrient requirements of fish production levels of 300-600 kg in a year.

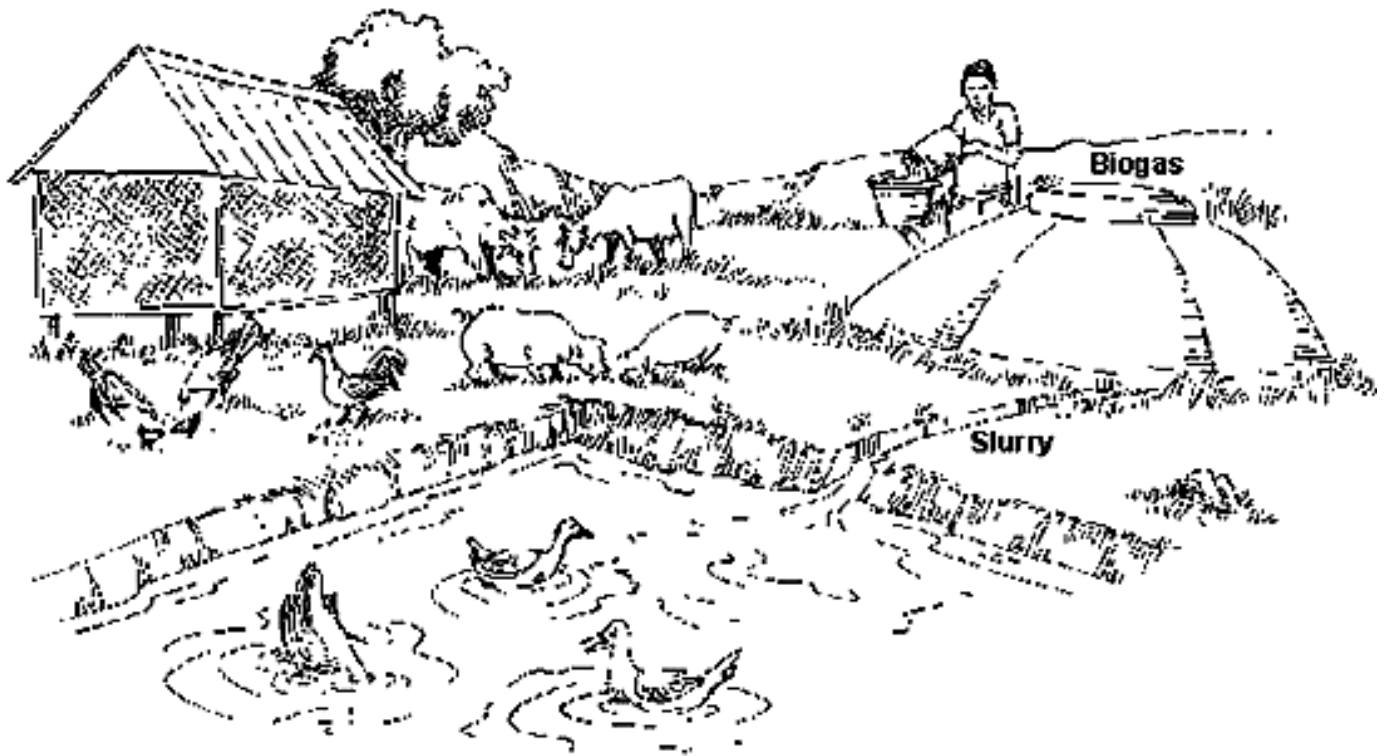

Integrated fish farming

Prepared by:
S. Ayyappan

Promoting Rice-Based Aquaculture in Mountainous Areas of Vietnam



An indigenous rice-fish culture system using a local strain of common carp, *Cyprinus carpio*, was carried out in valleys in the mountainous areas of northern Vietnam. The self-contained, family-level system provided fish primarily for household use. Excess fish were dried or made into fish sauce for consumption during the dry season.

Broodstock of the local strain of common carp are over-wintered in small ponds or cages. At the beginning of the rice season, they are taken to the rice field. Eggs are usually placed on branches or other structures placed in the field for that purpose. Hatching, nursing and grow-out are carried out in rice fields. Small fingerlings are stocked in rice fields at a density of 2000-3000 fish/ha.



Fields are not structurally modified, though some have small banded fish refuges, which are 1.5-2.0 m in diameter and 1.0 m deep. The refuges are usually located at the center or corner of the field. Several openings allow frequent exchange of water and fish between the ricefield proper and the refuge.

The refuges serve as a cool place for the fish when the rice field temperature is high. In some places, a certain percentage of the fish is harvested earlier to avoid losses when the rainy season starts.



In the early 1960s, fish farming in rice fields declined in areas where cooperatives focused on intensive rice production. However, this trend has been reversed with households increasingly reverting to rice-fish farming. Over 80% of the households in Thuanchau and Tuangiao are now growing fish in ponds or rice fields.

Benefits from rice-fish culture

The crop is profitable because both fish and rice are high-value products.

Fish culture in rice field is not exclusively for consumption but also for producing fingerling to be stocked in cages.

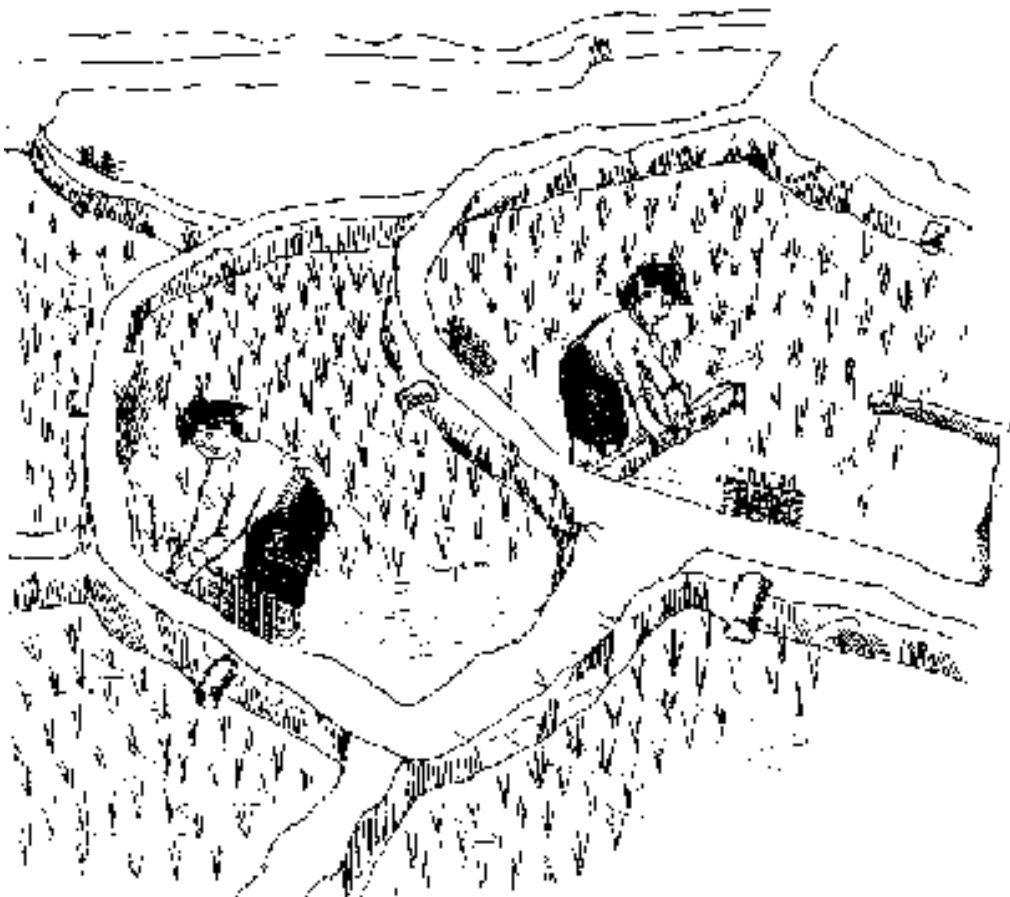

Cultivating rice and fish together provides other benefits:

- fish reduce pests, insects and weeds harmful to rice and provide additional nutrients for rice.
- The feeding activity of the fish helps to aerate the soil and to increase the availability of applied fertilizers.

Designing the rice fields

Requirements

The design of a rice-fish field requires a suitable mechanism of water filling/drainage for a water pH of 6.5 to 7. There are two methods to check the acidity of water:

- A traditional method involves the use of betel juice. Spit betel juice into the water. If the betel juice remains red, the water is safe for fish culture. If the color turns black, it means that the water is acidic and unsafe for fish-culture.
- Use litmus paper. If the paper turns blue, the water is safe for stocking fish.



Field design

Due to the mountainous topography, inlets and outlets should be created for the terraced plot.

A system of trench and trap pond is recommended, which covers five to ten percent of the area of the plot.

At the outlet, a fence is necessary to prevent

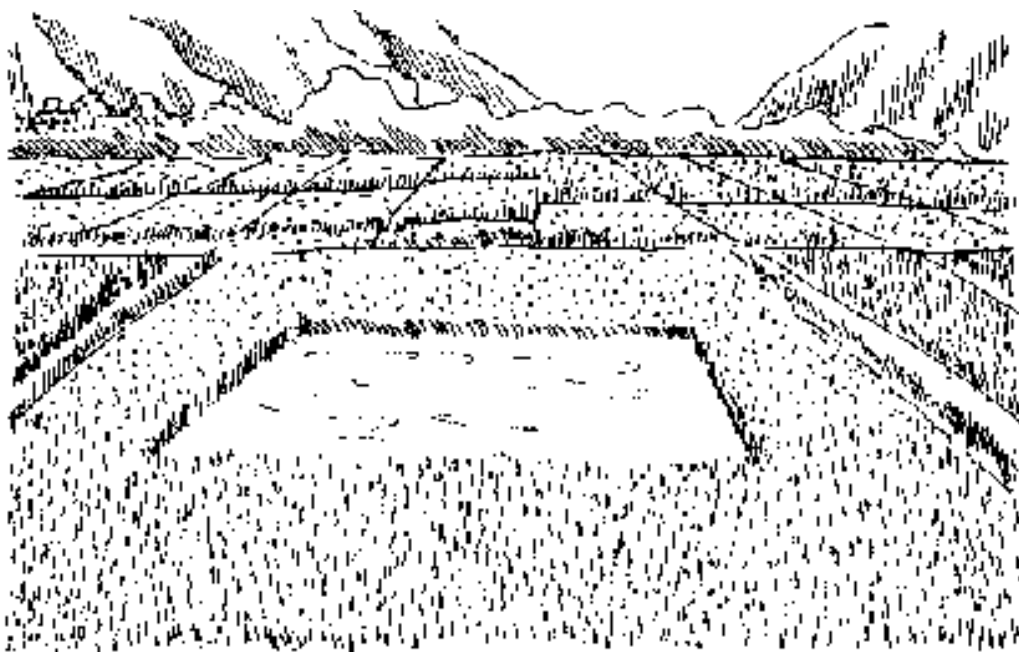

the escape of fish.

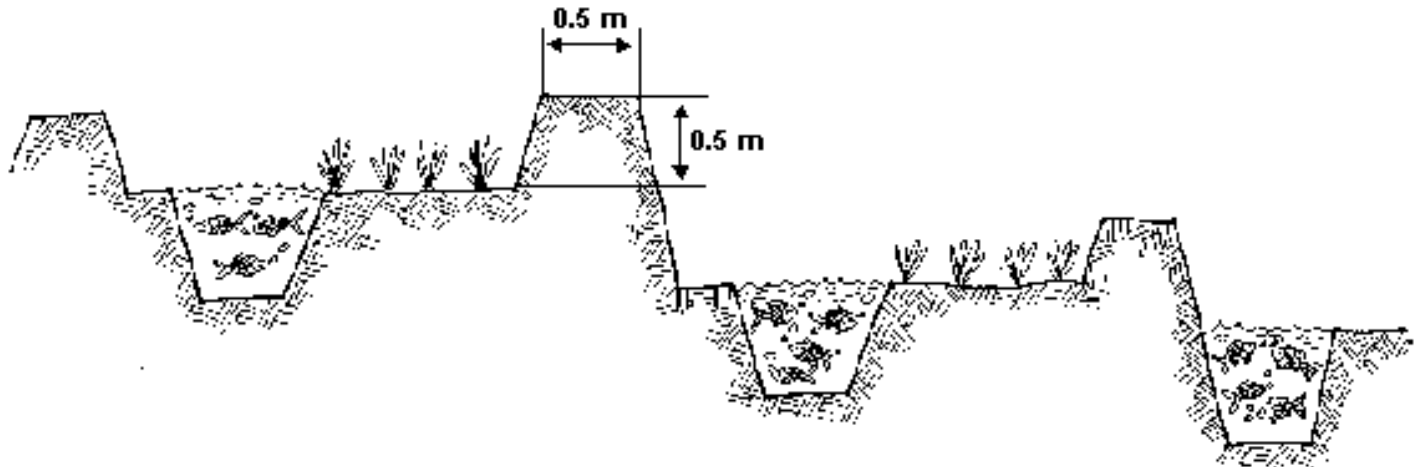

Field upgrading

- Drain the pond completely after harvesting the last crop products.
- Fill the trench/trap pond with 10 to 12 kg of quicklime/100 sq m. If pH is less than 5, use 20 to 24 kg per 100 sq m.
- Add animal manure at 20 kg/100 sq m.
- To drive away predaceous fish: Chop derris roots and add water. Splash the solution over the trench/pond on a sunny day. Leave the solution for three to five days before filling the pond.



Stocking period

The fingerling can be released eight to ten days after transplanting rice. Preferred stocking density, size and ratio of various species are recommended in the following table.

Stocking density and size					
1fish- 1rice crop			2rice- 1fish crop		
– stocking density: 2500 fish/ha			– stocking density: 2000 fish/ha		
– polyculture ratio and stocking size			– polyculture ratio and stocking size		
Common carp	50%	6-8 cm	Common carp	50%	6- 8 cm
Rohu	5-10%	6-8 cm	Rohu	5-10%	8-10 cm
Grass carp	20-25%	8-10 cm	Silver carp	5%	8-10 cm
Silver carp	5-10%	8-10 cm	Tilapia	20-25%	4-6 cm
Tilapia	10-15%	4-6 cm	Silver barb	5-10%	4-6 cm

Transportation of fingerlings from rearing site

The best way to transport fish is to use a plastic bag containing two thirds oxygen and one third water. Often, middlemen deliver (on motorbikes) fish seeds brought from the lowlands.



Before releasing the fish, make sure that the water temperatures inside and outside the bag are balanced to reduce temperature shocks. This is ensured by dipping the bag into the water for 15 minutes.

Care of the field

In May or June, prior to harvesting the spring-summer rice crop, fish are given rice bran at a rate of 3-4% of its body weight. In addition, 10-12 kg of animal manure per 100 sq m plots can also be added on a weekly basis.

Immediately after harvesting the rice, the field should be plowed and harrowed in preparation for the next rice crop.

The following should be closely monitored everyday:

- water level;
- fish activities;
- fence;
- inlets and outlets;
- rice growth; and
- damage by pests and insects.

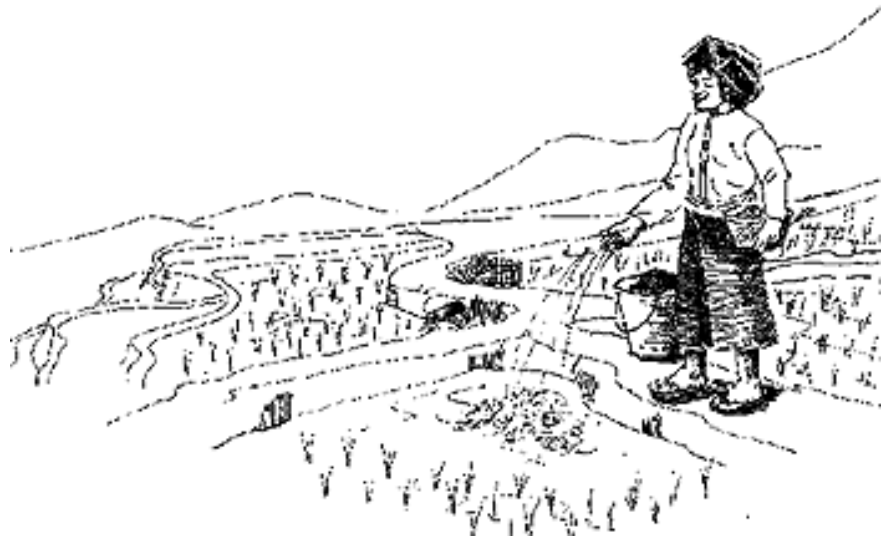

If necessary, spray with pesticide as part of the Integrated Pest Management (IPM). To do this, drain the rice field gradually to force the fish into trenches and trap pond. Then, spray the rice field and leave it for six to seven days before refilling the rice field.

Harvesting

The pond is drained and a net is used to catch all the fish. This is done before complete harvesting.

Harvesting is done at the end of the autumn-winter rice crop (November-December).

Harvesting size (g/fish)	
Common carp	300- 500
Rohu	300- 500
Tilapia	50 - 150
Grass carp	800- 1000
Silver carp	300- 400
Yield	60-1000 kg/ha/year

Prepared by:

Nguyen Huy Dien, Tran Van Quynh, Matthias Halwart and Dilip Kumar

Aquaculture in Stream-Fed Flow-Through Ponds

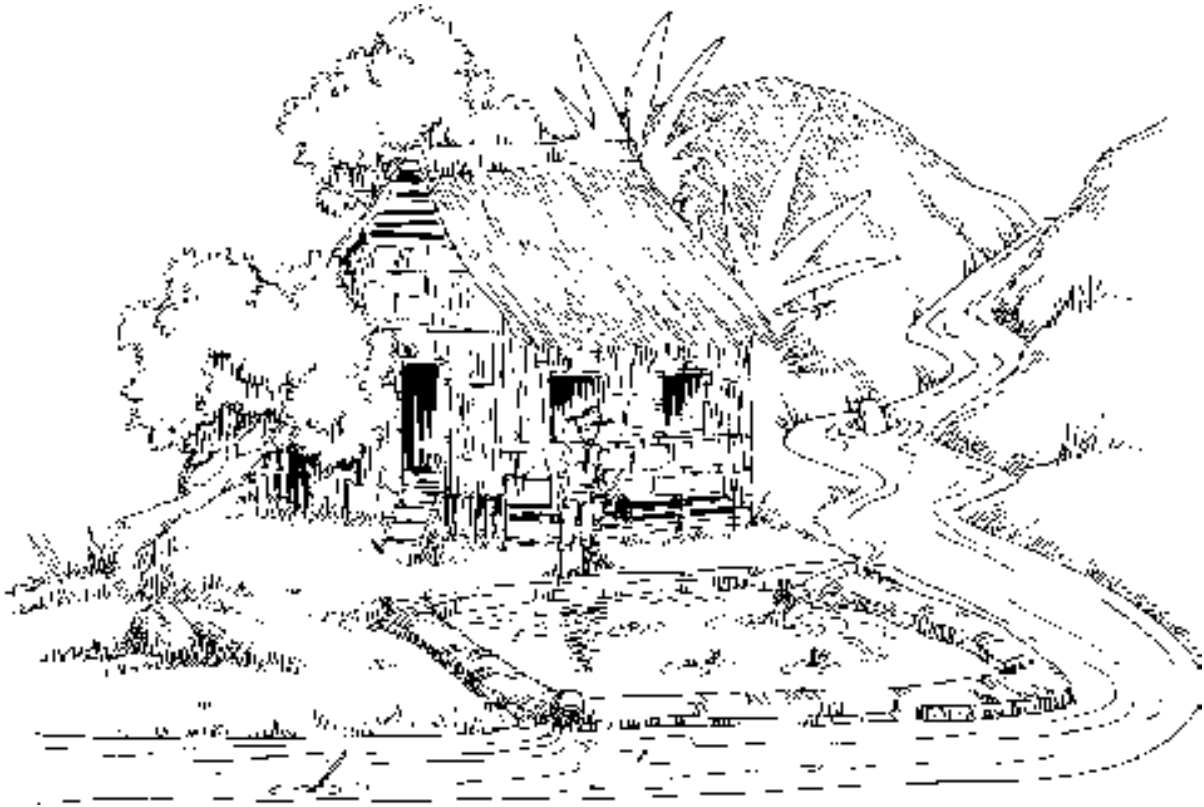

Stream-fed, flow-through pond systems are a low cost and highly efficient small-scale aquaculture system being introduced in the upland areas of Vietnam. The main cultured species in this system include some herbivores: grass carp (*Ctenopharyngodon idella*); "bong" (*Spinibarbythis denticulatus*); silver carp (*Hypophthalmichthys molitrix*) and tilapia (*Oreochromis niloticus*).

The system is considered semi-intensive because the water flow through ponds allows fish to be stocked at high densities. The circulating water flow maintains a good pond environment, preventing a drop in oxygen level and waste accumulation. As a result, the incidence of fish diseases is minimized. However, during the rainy season, the water supply gets turbid and contaminated with sediment and wastes from the catchment area. Farmers may sometimes encounter the problem of red spot disease in grass carp in the rainy season.

Pond construction

Stocking

Stocking density

2-3 fish/sq m

Stocking rate

Grass carp: 65%

Mrigal: 15%

Silver carp: 5%

Common carp: 10%

Tilapia: 5%

Stocking size

Grass carp: 15 - 20 cm

Mrigal: 8 - 10 cm

Silver carp: 8 - 10 cm

Common carp: 6 - 8 cm

Tilapia: 5 - 7 cm



Common cultivable species

- Grass carp
- “Bong”
- Mrigal
- Common carp
- Silver carp
(*Hypophthalmichthys molitrix*)
- Tilapia (*Oreochromis niloticus*)



Sample fish feeds

- Maize leaves
- Cassava leaves
- Banana leaves
- Native grasses
- Cassava tuber
- Banana trunk
- Sweet potato
- Duckweed



Chopped leaves can be given to small fishes. Starched feed such as rice bran and maize powder can complement green feed.

Feeding and post-stocking care

Feeding is undertaken twice a day. Feed quantity is estimated at 25-30% of the total fish body weight. Keep starch feed (1-2%) at one of the pond corners. Wastes and remains from the previous feeding should be removed before new feed is added.

Daily monitoring is very important. When fish surfacing is observed, add water as necessary. Semi-intensive levels require more frequent supervision.

Harvesting marketable fish

Harvesting size

Grass carp: 2 - 3 kg

Mrigal: 0.4 - 0.8 kg

Silver carp: 0.7 - 1.5 kg

Common carp: 0.4 - 0.8 kg

Tilapia: 0.15 - 0.25 kg

Expected yield/year: 3 - 5 tons/ha

Small fish could be retained for the next crop. Ponds need to be prepared for the next season.

Construction sites

- These areas are close to stream, rivulet, channels, canals and other places where free-flowing water source is available.
- Gravel, rocky or barren soil bottom is suitable as the pond is fed by flowing water.

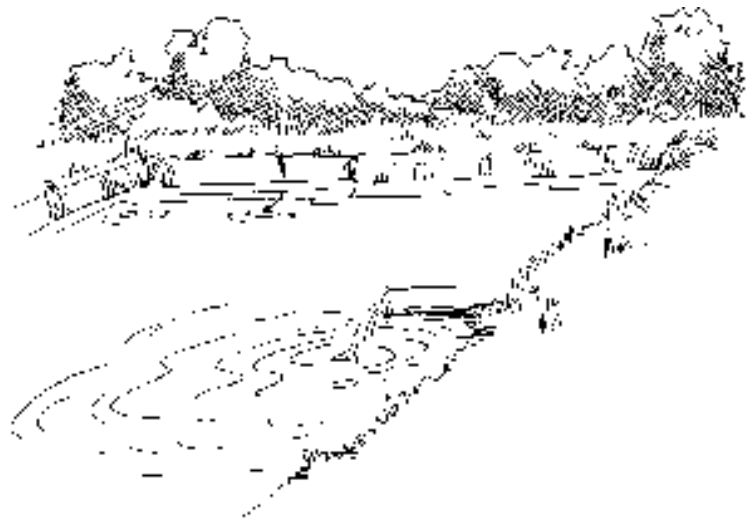

Pond shape

- Depends on the topography but with an area of about 50 to 1000 sq m.

Inlet and outlet size

- Depends on pond area.
 - Makes use of 10 cm (diameter) bamboo pipes connected to the water source.
 - Larger ponds need 2-3 inlets to ensure adequate water flow and to provide daily water exchange rate of up to 1/4-1/3 of the pond volume.

Both ends of the inlet need to be screened with a net to prevent small fish from escaping, and rubbish from entering the pond. Outlets are also screened to prevent fish from escaping.

Pond cleaning

Bailing and dredging of pond are done annually or at least once every two years. To ensure adequate water level, maintain the pond depth.

Liming

Acidic pond water

Add 10-20 kg of quicklime/100 sq m.

Neutral pond water

Apply quicklime at 7-10 kg/100 sq m to disinfect the pond and kill wild fish.

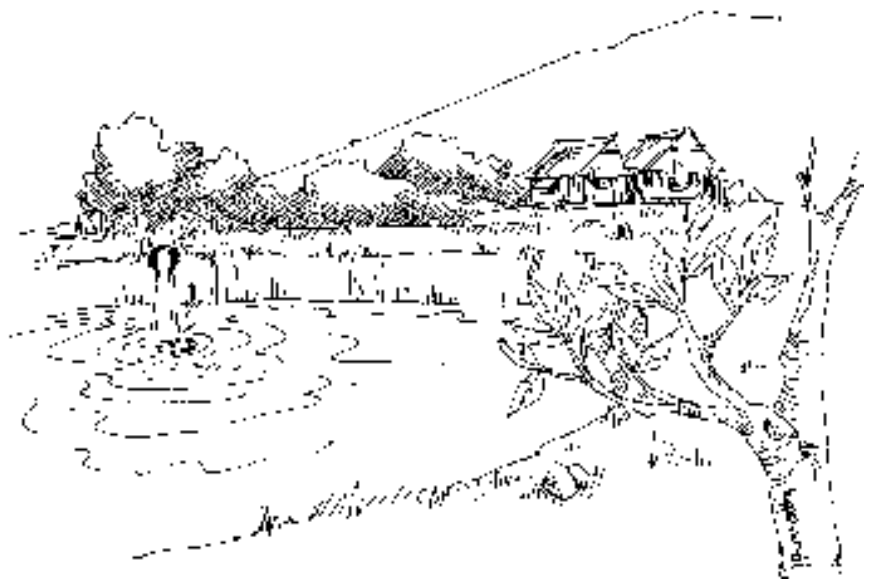

Prepared by:
Nguyen Huy Dien and Tran Van Quyhn

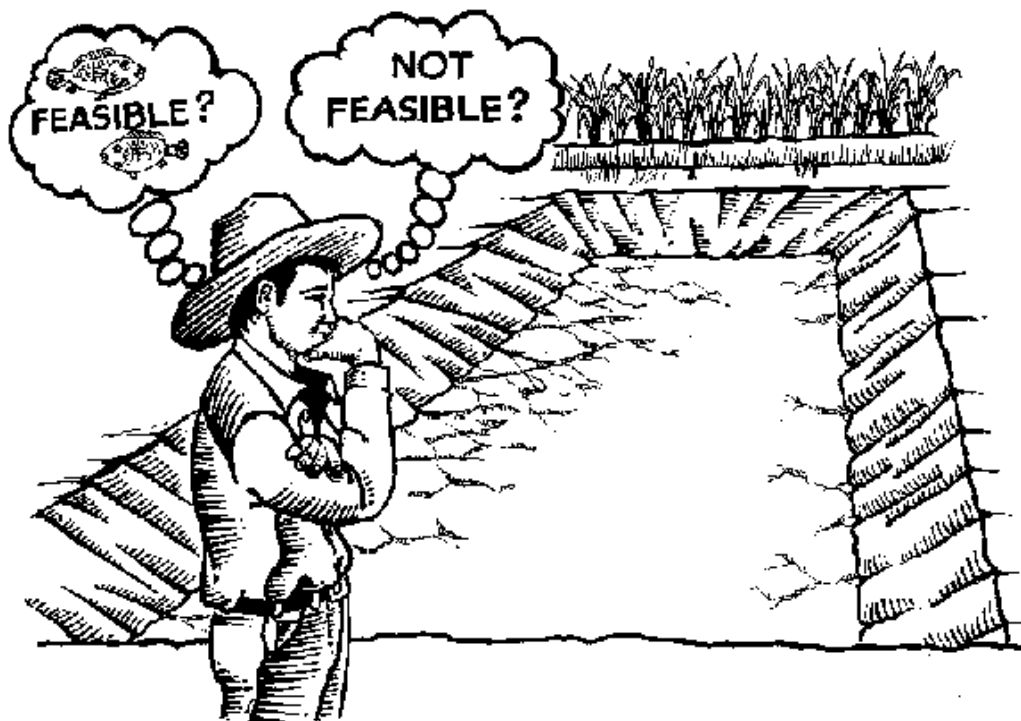

- How can the fish be harvested? Are there value added options that could increase

In Bangladesh, a widowed woman stocked newly hatched carp fry into a seasonally flooded borrow pit beside her farm house. She realized a quick profit in 60 days by selling the resulting fingerlings for others to grow out in perennial ponds.



- profitability (such as fee fishing, live hauling to fresh fish markets or making a processed product like smoked fish)?
- Are dikes adequate to retain water or prevent flooding?

Ownership or use rights of seasonal ponds and the exposed dry area could be a source of conflict, thus, should be clarified. If the resource is of communal ownership or there is a tradition of open access, this could be problematic and could hinder any sort of investment for aquaculture production.

Short-Cycle Aquaculture in Seasonal Ponds

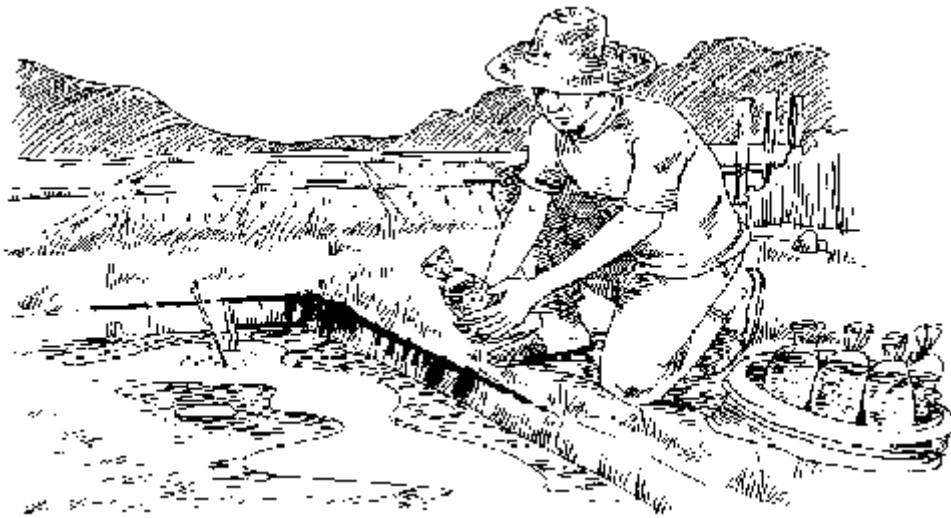

Using seasonal ponds for aquaculture is often an overlooked opportunity. These are ponds that lose their water during the dry season or overflow during the rainy season. Three to six months can be adequate to produce a fish crop in such an environment. Care is needed not to overstock the ponds to ensure that there will be sufficient food for the fish to grow in such a short time. Selecting the species to be used will depend on local conditions and availability of seed stock and market demand. The fish carrying capacity of an un-enriched pond is often within 50-200 kg/ha depending on the natural fertility of the system and the type of fish present.

By enhancing the natural fertility through fertilizers and organic manures, it is possible to increase carrying capacity to over 1000 kg/ha. To do this, the stocked fish need to be low on the food web or of mixed species, each taking advantage of different food niches in the pond. Fast growing fish like carps and tilapias are particularly suited for this sort of aquaculture. Even high value organisms such as *Macrobrachium* prawns could be considered for stocking. For short production cycles, start with medium-sized fish and work to get them up to premium market size in the time available.

Even greater carrying capacities can be achieved by using supplemental or complete feeds. The higher the percentage of externally produced feeds, the higher the quality of the feed must be. Feeds can be costly so the economics -- profit on investment -- need to be watched closely. The capacity of the pond to assimilate organic manures or feeds without losing the dissolved oxygen during nighttime is limited so the pond should not be overloaded with organic enrichment.

Sri Lanka has 10,000 seasonal village tanks ranging from 0.3 to 50 ha. Stocked with mixed carp species, these can typically yield about 400 kg/ha in the 6-8 month production season just from the manure left by grazing animals during the dry season. Fish yields as high as 2,500 kg/ha have been recorded with the addition of fertilizers and supplemental feeds (Jayasekara 1998).



Good aquaculture management practices for perennial ponds also apply to seasonal ponds. These include security measures, control of unwanted pollution from erosion or harmful pesticides, removal of unwanted wild fish and destructive predators, and a marketing strategy. Local conditions should dictate what aquaculture practices to consider. The basic considerations are:

- Availability of stocking material (e.g., must larger fingerlings be held over from the previous year to get a jump on the production season?)
- What species and size of fish will sell well (including possible fingerlings from a nursery operation)

In starting such a venture, it would be useful to know the following:

- the surface area of the pond water at stocking and the expected area near harvest time;
- some things about water alkalinity (ponds with low alkalinity may need lime applications to help in the production of natural foods); and
- the average daily temperatures during the culture period.

Reference

Jayasekar, A.M. 1998. Rural Aquaculture: Role and Trends. Paper presented at National Workshop on Aquaculture for Rural Development, Sarasavipaya, Colombo, Sri Lanka.

Possible system

A sex-reversed male Nile tilapia has the biological potential to grow from a 50-g fingerling to a 500-g fish in 6-8 months. A well-fertilized pond with a good plankton bloom should have a carrying capacity of at least 1000 kg/ha of the fish. Thus, a stocking rate of 2000 fingerlings/ha (pond area at harvest time) has the prospect of yielding a bigger sized fish in a relatively short growing season provided that water temperatures stay above about 25°C and assuming a high survival rate. This basic model should be modified according to local conditions and experience in a particular system.

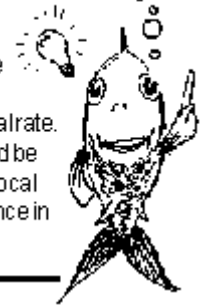

Prepared by:
John Grover

Resources for: PROCEEDINGS OF THE 1998 WORKSHOP ON RURAL RECONSTRUCTION (RRC), International Development Research Centre (IDRC), Food and Agriculture Organization of the United Nations (FAO), Network of Aquaculture Centres in Asia-Pacific (NACA), International Centre for Living Aquatic Resources Management (ICLARM), Asian Institute of Technology (AIT), The Netherlands Embassy in the Philippines, German AgroAction (GAA) and Southeast Asian Fisheries Development Centre (SEAFDEC).



Low-Cost Aquaculture in Undrainable Homestead Ponds



Low-cost aquaculture has been practiced extensively throughout Bangladesh and some eastern states of India like West Bengal, Orissa, Tripura, Assam and Bihar. It has been proven to be ideal for enhancing food and nutritional security and supplementing cash income of families. The system is based on better utilization of food niches available in the pond ecosystem by stocking Indian and Chinese major carp species with compatible feeding and dwelling habits.

Suitable for families with the following resources

- Pond

Undrainable, seasonal or perennial (all year round), family owned or leased, nall

homestead (up to 0.1 ha) or communal (less than a ha to a few ha)

- Manure

Organic manures (5-7 kg of manure/day for a 0.1 ha pond)

– Animal excreta from family livestock like cattle dung, poultry/duck droppings

– Farm wastes

– Compost

- Kitchen wastes
- Green manure using leguminous plant (dhanicha/sun pat/green gram)

Inorganic fertilizers (200-250 g/day for a 0.1 ha pond)

- Urea
- Triple super phosphate
- Muriate of potash

- Supplementary feed

Rice bran and deoiled cake (to limited extent)

- Piscicide

Any of the following: mahua oil cake, locally available materials of plant origin, rotenone, bleaching powder, phostoxin tablets, etc.

- Lime

- Fish seed

Fingerlings of Indian and Chinese major carps, juveniles of freshwater prawn, etc.

- Family labor

Contributed by women, men and children

Package of practices

Pre-stocking management (Pond preparation)

Eradication of weeds

- Trim the branches of trees shading the ponds to ensure maximum penetration of light.
- Remove all the submerged, rooted and floating aquatic weeds to avoid nutrient

trapping and to ensure penetration of sunlight.

- Drain and dry the pond (once every three to four years for perennial ponds which retain water throughout the year). Draining is done during summer months when water level is low.
- When the pond has dried, scrape off the upper layer of the bottom sediment and repair the pond dikes. The sediments removed can be utilized as good manure for crops.
- In some cases, when the pond dries up (especially in case of seasonal ponds) the bottom is plowed and any green manuring agent like dhanicha (*Sesbania spp.*) is sown at 30-35 kg/ha.
- After 30-40 days, plow the plants down and allow them to decompose in the rainwater which has accumulated in the pond.

Advantages

- Quick return – about 45-50% of the cost is recovered within 3-4 months.
- Due to smaller daily dose, any abrupt change in the water quality is avoided.
- Depends largely on own farm/household resources.



Eradication of predatory and other small fishes

The best course is to drain and dry the pond once in two to three years. An alternative method is to apply any of the following locally available piscicide material and to remember that toxicity usually lasts for seven to 10 days.

- Bleaching powder at 50-70 g/sq m/m depth.
- Rotenone powder at 2-3 g/sq m/m depth.
- Mahua oil cake (deoiled cake of the seed of mahua tree, *Bassia latifolia*) at 250 g/sq m/m depth.
- Though aluminum phosphide (Phostoxin tablet) is not recommended, many farmers in Bangladesh have been seen using it at 1 tab (3 g)/10 sq m depth.

Caution!

Residual effects of aluminum phosphide (Phostoxin) tablets are unknown and may cause health and environmental hazards.



Liming

- Apply lime to the pond at 25 g/sq m/m soon after draining or after applying piscicide.
- Increase the quantity of lime for older ponds with relatively thick, soft bottom sediment or soil with low pH.
- Lime does not have to be added when bleaching powder is used to eradicate weed/predatory fishes.

Tip

Lime has broad spectrum impact on pond environment and nutrient dynamics. It acts as a disinfectant and kills disease-causing agents, prevents abrupt changes in pH and enhances the mineralization process.



Bottom raking

(Exceptions: newly dug out and sandy ponds)

Vigorously rake the bottom of the ponds after liming by dragging a rope tied to stone or brick pieces. Heavy rings of burnt clay materials are also used for this purpose. Raking enhances the rate of the microbial decomposition process and release of marshy gases.



Base manuring

After five to seven days of liming, both organic and inorganic manures are applied to the pond.

Organic manure

- Cattle dung at 100-150 g/sq m
- Poultry/duck droppings
- Compost at 50-75 g/sq m

Inorganic fertilizers (any of the following)

Urea at 200-250 g/100 sq m

Triple super phosphate at 100-125 g/100 sq m

Muriate of potash at 50 g/10 sq m

Note

- Do not apply manure when the water in the pond turns deep green within a week of liming.
- Base manuring is not required if green manuring was done.
- The amount of manure required for base manuring is equal to the amount applied for one month through daily doses.



The desired quantities of organic and inorganic manures are mixed with adequate water (three times the volume of manures) and applied uniformly by sprinkling throughout the pond surface.

Compost can be easily made by using farm wastes, water hyacinth, straw and other plant materials. A pit is made and these materials are dumped in layers of 25-30 cm, alternating with urea applied at the rate of 2% of the total plant material's weight. After making several layers, the pit is covered with soil. Several holes are made and within three to four weeks the compost becomes ready for application.



Stocking management

When to stock:

One to two weeks after manuring.

Larger fingerlings from the previous year's stocks are preferred for better survival and quick growth.

After rearing for three to five months, partial harvesting is done and the stock is replenished by restocking.

Stocking density and combinations

Depending upon the culture practice, two levels of stocking densities are followed:

- When there is no possibility of providing supplementary feed on a regular basis keep stocking density at 5000-6000 pcs/ha.

- When farmers have the capacity to provide supplementary feed on a regular basis increase the stocking density to about 7000-9000 pcs/ha.
- Stocking density may be reduced if bigger individual size is targeted for harvesting. Bigger size fish sells at 10-20% higher price.

The common species stocked in the ponds are combination of native and exotic major carps such as catla (*Catla catla*), rohu (*Labeo rohita*), mrigal (*Cirrhinus mrigala*), silver carp (*Hypophthalmichthys molitrix*), grass carp (*Ctenopharyngodon idella*) and common carp (*Cyprinus carpio*), etc.

Tip

Larger size fingerlings (10-15 cm) ensure better survival, growth and bigger individual size at harvesting.



Species combinations for stocking also vary depending on the nature of ponds (shallow or deep, newly dug out or older, sandy bottomed or heavily loaded with organic materials, etc.), local market demand and local availability of larger size fingerlings. The percentages of column and bottom feeders are generally increased in deeper and older ponds, respectively.

Stocking of juveniles of freshwater prawn (*Macrobrachium rosenbergii*) with carps is also becoming popular. In such cases, the number of bottom feeders is reduced to about 5-10% and juveniles of prawns are stocked at the rate of 2500-4000 pcs/ha.

Niche	Species	Stocking density
Surface feeders	Silver carp (<i>Hypophthalmichthys molitrix</i>)	40-50 %
	Catla (<i>Catla catla</i>)	
Column feeders	Rohu (<i>Labeo rohita</i>)	20-25 %
Bottom feeders	Mrigal (<i>Cirrhinus mrigala</i>)	20-25 %
	Common carp (<i>Cyprinus carpio</i>)	
Microphyte eaters	Grass carp	5-10 %

Prophylactic treatment

Before stocking, bathe fingerlings for one to two minutes in either common salt (1-2% or two hands of full salt in 10-12 l of water) or potassium permanganate solution (1-2 teaspoon/bucket of 10-12 l of water).

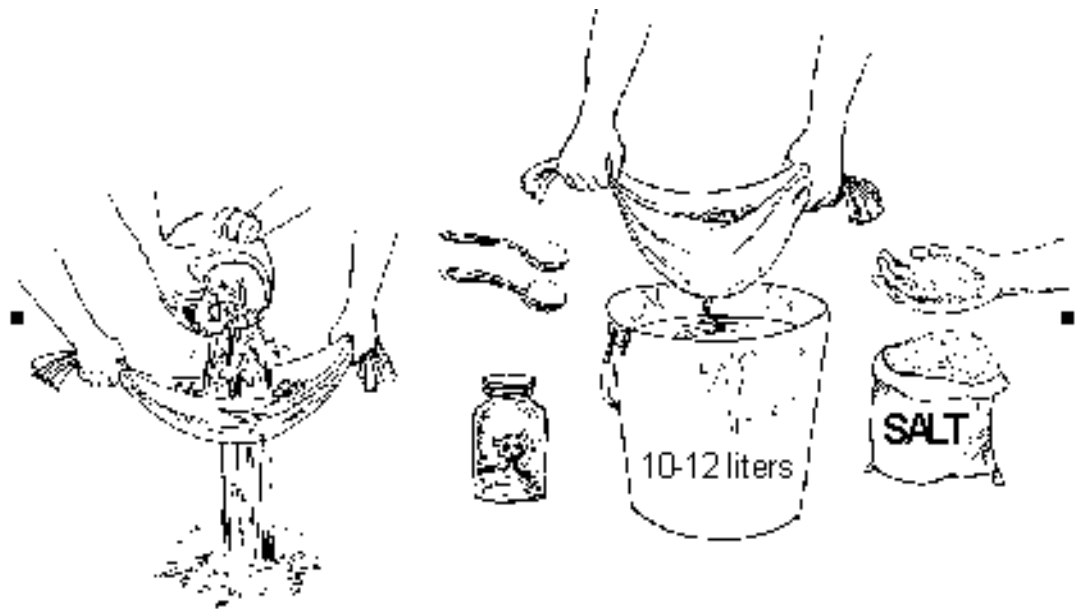

Post stocking management

Fertilization

- Mix the desired amount of organic manure and inorganic fertilizers with water three times that volume and sprinkle throughout the pond during bathing time (noontime).
- Reduce or suspend fertilization if the water turns deep green (such incidents are common with old ponds with thick bottom sediment and community ponds surrounded by dense human settlement).

Important

Regular manuring is very important to ensure continuous availability of natural fish food organisms in adequate quantity.



- For one bigha (0.133 ha) of pond area, which is the common size of homestead ponds, the farmers usually follow the manuring schedule.

Manuring schedule	
Organic/inorganic fertilizers	Amount applied for 1 bigha of pond (0.133 ha)
Cattle dung	1 small basket (5–7 kg)
Poultry/duck dropping/compost	½ basket (3-4 kg)
Urea	Two hands full (100-150 g)
Triple super phosphate	One hand full (50-75 g)
Muriate of potash	Half handful (20-30 g)

Feeding

Supplementary feed is considered to be the most expensive input in pond aquaculture and can account for over 60% of the total culture cost. As a result, most of the farmers do not apply feed on a regular basis.

However, for better yields and profits supplementary feed applied on a regular basis, if affordable, is helpful.

Locally available feed materials like rice bran and deoiled cake of mustard, and other oil seeds are used in equal proportions and applied at the rate of 1-2% of the fish biomass on a daily basis. Depending upon the availability and cost considerations, some farmers use only rice bran. Feed is given either in powdered form or dough. Again, depending upon their availability, macrophytes or green leafy plants are used as supplementary feed for grass carp.

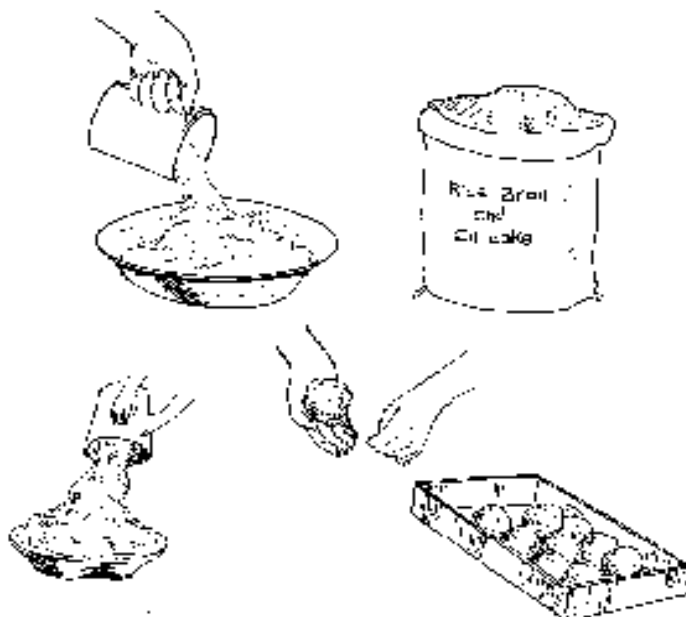

Periodical netting is done at least once a month to check the health and growth of the fish and take the weight of individual species. Feeding rate is adjusted after estimating the fish biomass.

Bottom raking

Rake the pond bottom of older ponds with thick, organic deposits.

This speeds up the decomposition process, releases marshy gases and aerates the bottom sediment. It is best to do the raking during noontime.

Caution



Suspend manuring if there are any signs of algal bloom or depletion of dissolved oxygen levels. Increase the dose for newly dug out ponds if the water is clear. Dawn surfacing offish and gasping are signs of dissolved oxygen depletion.

Harvesting

Partial harvesting

Some of the fish species like catla, silver carp and common carp (mirror carp) grow relatively faster and reach marketable size within three to four months of rearing.

Growth is also remarkable when bigger size fingerlings are stocked (eight to 10 months old) during warmer months (March-April). Some of the species can grow to about 1 kg size within four to five months and partial harvesting is carried out after four to five months of rearing.

Restock immediately after harvesting to restore density.

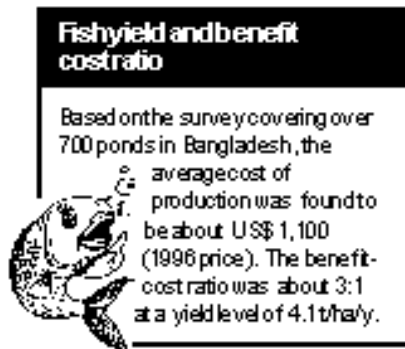

Final harvesting

Final or complete harvesting is done once a year, usually in February to May. Harvesting is also synchronized with certain social and religious events when the fish price increases due to increased market demand.



Homestead Fish Culture: An Example from Bangladesh



A large percentage of the Bangladesh population is poor. The poorest find themselves in a vicious cycle because they do not have collateral for prime income-generating activities. Many attempts have been made to break this cycle. The micro credit schemes operated by several non-governmental organizations (NGOs) are a good example of such attempts. The main idea is to give people access to resources with which to generate income that they can use to acquire more resources to generate more income.

Instead of providing money or other means for acquiring resources to generate income, another approach to the poverty problem is to try to find a way to generate income with available resources. In Bangladesh, most poor people can work. They have access to labor, some land on which their shack is built, water, and other things the area (or fields) around their home can provide.

An income generating activity making optimal use of these resources is homestead catfish culture, practiced in the project area of the Compartmentalization Pilot Project (CPP) in the central region of Bangladesh. This practice was taken up by the CPP and further refined into a homestead fish-culture program. Requirements for this activity are:

- food for fish;

- a small pit;
- water; and
- fry

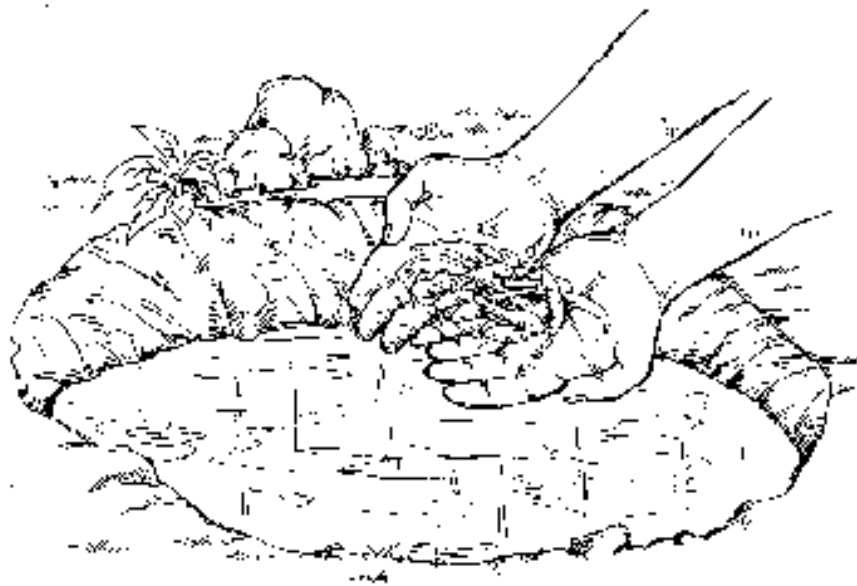

Fish food can be collected from the surroundings of the homestead (snails, bivalves, termites, ants, slaughter waste, etc). The pit does not have to be large: one square meter is enough for 50 fry and it can be dug by the participants themselves. Catfish fry is widely available in Bangladesh at reasonable prices (between 10 to 50 Taka [US\$0.2 to US\$1] for 50 pieces). After a rearing period of four months, 5-6 kilos of African catfish can be harvested, valued

at approximately 400 Taka (US\$8).

The concept of homestead catfish culture

The basic concept of a homestead catfish culture program is to introduce the poorest people to an easy method for culturing fish in small holes or pits around the homestead. The African catfish (*Clarias gariepinus*) is used because it is known to take up oxygen from air, has a high growth rate and is very disease resistant. Experience shows that people adopt the method as soon as they are introduced to it. After successfully raising a first batch of fish, initiatives are undertaken for continuing the activity (such as contacting local fry traders or trying out different food sources locally available).

Training is done on site, at the homestead. Field staff work with around 50 participants at a time. The first step was the identification of participants. To ensure that the poorest of the poor received priority, a general review of the participants' situations was made. To be selected for the program, potential participants had to meet a few criteria.

They had to be landless (people with less than 200 sq m of land are considered landless in Bangladesh).

Their general situation was poor.

Their house had mud, bamboo or jute walls.

Potential participants who met all criteria were asked about their interest in the program, which involved their buying fry for a reduced price (10 Taka, US\$0.20) from the field officer.

Four basic rules for catfish culture were provided the participants who bought the fry:

1. The fish should be fed every day (preferably until they do not want to eat anymore).
2. The food can be anything, except grass and plastic, but the best is protein-rich feed.
3. Water in the pit should be changed as soon as it started smelling bad.
4. Special attention should be paid to the sizes of the fish (they have to be of about the same size range to prevent cannibalism) during the change of water.

Two to three days after the sale of fry, the field officer visits the participants. Participants not visited within these three days have failed to rear their fish successfully. After the first two contacts, the household was visited every three to four weeks to monitor their progress and to answer any questions concerning fish culture.

Participating households

Two hundred households participated in the homestead catfish culture program. The average size of the households was around five. Most male household members (84%) had an income-earning job that paid on average 49 Taka per day. On the other hand, most of the women in the selected households stayed home (90%) and were not earning money. The women who did have jobs earned less than the men as the average daily income for women was 15 Taka. A small number of children (2%) generated additional income, on average 22 Taka per day each. Sixty percent of the children went to school, with primary level being the highest reached by the children. On the whole, the daily income per household was around 60 Taka. The participating household members had two to three meals per day, consisting mainly of rice and vegetables. Three times a week the vegetables included pulses (dal), which have high levels of protein. Twice a week meals were supplemented with fish, once every two weeks with meat, and once a month chicken. Eggs and milk were consumed less than three times per week.

Care of the pit

Women took care of most of the pits (80%), followed by the men (15%), then children (5%). Care of the fish consisted mainly of collection of fish food, which could come from around the homestead since catfish eat almost anything. Children assisted caretakers in the collection of food. Food collection costs amounted to zero. Supplied food consisted mainly of snails (46%), rice (18%), wheat bran (9%), rice bran (9%), bivalves (6%), or slaughter waste (5%). In some cases, termites, earthworms, wheat powder, cow dung, fish, bread and duckweed were used. On average, the water in the pit was changed every 10 to 12 days. The average time spent on the system was 1 hour per day. Caretakers themselves made decisions concerning management of the pits and, more importantly, what to do with the fish.



Season

African catfish will grow when the water temperature is higher than 20°C. For the program to succeed, a minimum water temperature needs to be guaranteed. This can be done by either having a growth season during the summer or ensuring a supply of water with a minimum temperature of 20°C. Some of the participants replaced the water in their pit everyday with tube-well water (usually 21°C).

20 households were not able to grow their fish to marketable size (>75 g) due to several reasons:

- ⊗ Insufficient guidance by the project staff (not visiting the household within 3 days after distribution of the fish or not visiting the household every three to four weeks).
- ⊗ Not enough time spent on the management of the pit by the responsible person in the household (less than one hour per day).
- ⊗ Escape of fish (after flood, or heavy rain).

Over a 6-month period, 158 new households took up this method of fish farming without intervention from the regular program for a diffusion ratio of $158/200 = 0.79$.

Impact

One can describe the women involved in the program (80% of the participants) as being extremely dependent on their husbands. Only a small number of them (10%) earned a meager income (15.2 Taka/day, US\$0.30). The rest relied solely on what their husbands earned, or made some money from occasional jobs and barter trade. An example of one of these occasional jobs is "biri" stick production. "Biri" is the local cigarette and "biri" sticks are the paper tobacco holders. The sticks are produced in the homestead and women earned 2.5 Taka per thousand sticks. On average, an adult can produce that number in three hours, so this means an income of 0.75 Taka (US\$0.15) per hour. Catfish culture requires, on average, one hour per day and it takes four months to produce five kilos of fish that sell for 400 Taka -- a return of 3.33 Taka per hour.

Evidently, the Homestead Fish Culture Program has had an enormous impact on people in the above-described situation. Five kilos of catfish (400 Taka, US\$8) in four months may not be much in the developed world but for participants they can mean the difference between food on the plate and nothing to eat at all.

Environmental aspects

In the homestead fish-culture program, the African catfish (*Clarias gariepinus*) is being used because of features mentioned earlier. These features are unique to the African catfish. The main reason for preferring the African over the local catfish (*Clarias batrachus*) is growth rate, which is much higher. Some reservations about the use of this exotic species exist: it is popularly believed in Bangladesh that the African catfish is a ferocious predator, capable of eating even small goats. It is feared that the African catfish will wipe out local fish populations. However, during the implementation of the homestead fish-culture program in Bangladesh, no evidence was found concerning the ferociousness of this fish. On the contrary, it was perceived as a lazy omnivore, eating whatever comes in front of its mouth.



demand is

Supply

At present there is a thriving industry in Jessore (south-west Bangladesh) where millions of catfish fry are produced per month. This industry produces for (illegal) export to India, and for the local market. Fry traders all over the country sell the African catfish. Previously the demand for catfish fry within the project area was low, so the market for these fry traders was not important. With the homestead fish culture program running now,

rising and fry traders are moving in to sell their fish. The traders distribute fry to homesteads directly, making it possible for women to buy fry at their homesteads.

Sustainability

The sustainability of the program depends completely on the availability of fry of the species involved. As long as the fry is available, the program has an opportunity to succeed.

Recommendations

The program used a species exotic in the Indian sub-continent. To prevent problems associated with the use of exotic species, this method should be tried with local species, which should meet the following requirements:

- Be able to survive in anoxic water (water without oxygen)
- Be easy to keep, should be able to eat what is available around the homestead
- Be fast growing
- Fry should be cheap and available
- Species must be acceptable to participants and the market

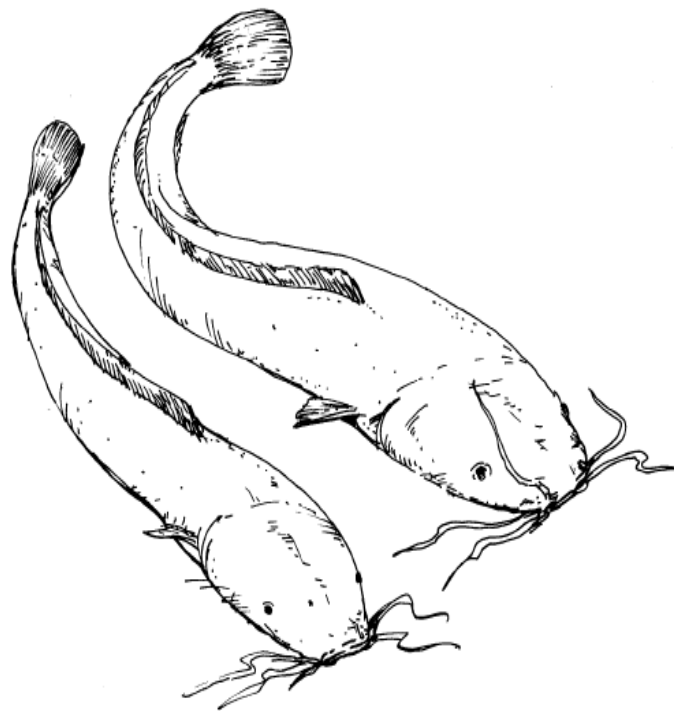

To ensure the African catfish does not contribute to serious environmental problems, research has to be undertaken on the ferociousness of the species before a large scale program is set up to spread this method.

As the poorest people will use common resources around their homestead, an impact assessment has to be made on the effect of homestead fish culture on the environment immediately surrounding the homestead.

Although it was not an objective, the program contributed to the improvement of the status of women. The method turned out to be a highly successful way to reach the poorest segments in the project area. The participants were highly motivated and very innovative. If proper research shows that there is no potential negative

impact, the method should be considered for wider use in Bangladesh and elsewhere.

Integrating Intensive and Semi-Intensive Culture Systems to Utilize Feeding Waste

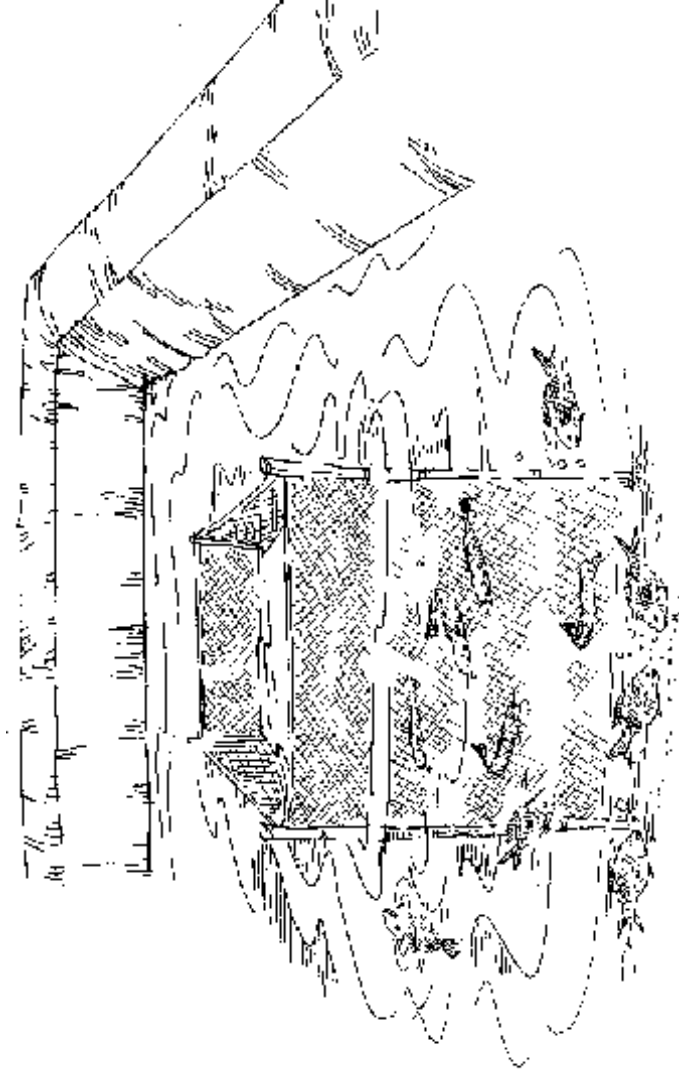

In intensive fish culture, fish are generally fed with high protein diets. The nutrient-rich wastes derived from feeding are often directly or indirectly released to the surrounding environment, becoming a source of pollution. The wastes from intensive fish culture can be used for culturing filter-feeding fish species such as Nile tilapia (*Oreochromis niloticus*) at low cost. Dual integrated culture systems, namely cage-cum-pond and pen-cum-pond culture systems, have been developed to maximize fish production and profitability from given inputs and to minimize the environmental impact of intensive fish culture.

Integrated cage-cum-pond culture system

- It is a system in which fish species intensively cultured with high protein diets are stocked in cages suspended in ponds.
- The filter-feeding fish species is stocked in open water to utilize foods derived from cage wastes.
- Cages are suspended at least 20 cm from the bottom of small earthen ponds. This system has no water exchange and aeration. If provided, aeration can increase both fish growth and nutrient recovery rates.

- Extending open-pond fish culture for sometime after harvesting caged fish can further reduce nutrient loading in pond effluents.

Example 1: Catfish/tilapia integrated cage-cum-pond culture

Hybrid catfish (*Clarias macrocephalus* x *C. gariepinus*) are usually cultured intensively using high protein diets, while Nile tilapia (*Oreochromis niloticus*) are cultured semi-intensively in fertilized ponds. These two species are used in the following

Summary of growth performance of caged hybrid catfish and open-pond Nile tilapia for 122 days				
Performance measures	One cage per pond		Two cage per pond	
	Caged catfish	Open-pond tilapia	Caged catfish	Open-pond tilapia
Surface area (m ²)	4	250	4	250
Water volume (m ³)	3.2	220	3.2	220
Water depth (m)	0.8	1.0	0.8	1.0
Stocking				
Density (fish/m ³)	275	2	275	2
Total number (fish/pond)	880	440	1760	440
Catfish:Tilapia ratio	2:1		4:1	
Total weight (kg/pond)	12.6	3.1	26.4	3.0
Mean weight (g/fish)	14.3	7.0	15.0	6.7
Harvest				
Survival (%)	95.8	90.5	87.5	69.8
Mean weight (g/fish)	273.8	179.2	270.2	297.2
Net yield (t/ha/year)	26.1	8.1	46.9	10.3
Gross yield (t/ha/year)	27.6	8.5	50.0	10.6
Total net yield (t/ha/year)		34.2		57.2
Total gross yield (t/ha/year)		36.1		60.6



example.

Example 2: Large/small tilapia integrated cage-cum-pond culture

Nile tilapia is commonly grown in semi-intensive ponds based on fertilizers or in integrated systems with livestock. Size at harvest, under such systems, usually averages 200-300g in five months. Larger Nile tilapias (around 500 g) fetch a much higher price than smaller ones (<300 g) resulting in a trend to culture bigger fish in intensive culture systems. Supplemental feeding of Nile tilapia, starting at 100-150 g in size, is the most effective way to produce large-sized fish. In this example, large tilapia fingerlings are fattened in cages with high protein diets, while small fingerlings are nursed in open ponds by utilizing natural foods derived from the cage wastes.

To optimize the system:

- Fatten large-size tilapia (approximately 140 g) to more than 500 g or bigger, in two cages in a pond with a surface area of 300-400 sq m and water depth of 1.2 m.
- Small-size tilapia (approximately 20 g) can be nursed to around 140 g size in open-ponds by utilizing cage wastes. These are removed every three months to restock the cages.

Integrated pen-cum-pond culture system

- It is a system in which a fish pond is partitioned into two compartments using netting material.
- The fed fish and filter-feeding fish are separated to utilize high protein diets more effectively and the natural foods derived from feeding wastes.

Example: Catfish/tilapia integrated pen-cum-pond culture

- Earthen ponds with surface area of 200 sq m and 1 m water depth are partitioned by 1-cm mesh plastic net into two compartments: 1/3 for hybrid catfish

Summary of growth performance of both caged and open-pond Nile tilapia with two cages per pond for 85 days			
Performance measures	Caged tilapia	Open-pond tilapia	
Surface area (sq m)	4	300-400	
Water volume (m ³)	4	300	
Water depth (m)	1.0	1.0-1.2	
Stocking			
Density (fish/m ²)	50	1.4	
Total number (fish)	400	462	
Large: Small tilapia ratio		1:1.2	
Total weight (kg/pond)	49.4	7.2	
Mean weight (g/fish)	124	16	
Harvest			
Survival (%)	98.8	92.0	
Mean weight (g/fish)	466	124	
Net yield (t/ha/year)	18.2	6.2	
Gross yield (t/ha/year)	24.9	7.1	
Total net yield (t/ha/year)	24.4		
Total gross yield (t/ha/year)	32.0		

Growth performance of hybrid catfish and Nile tilapia cultured for 87 days		
Parameters	Catfish	Tilapia
Compartment area (sq m)	67	133
Stocking		
Density (fish/sq m)	26	2
Total number of fish/pond	1675	266
Catfish: Tilapia ratio	6.3:1	
Mean weight (g/fish)	19.2	19.5
Total weight (kg/pond)	32.2	5.2
Harvest		
Mean weight (g/fish)	237.8	114.9
Survival rate (%)	93.8	92.8
Net yield (t/ha/year)	213.6	7.2
Gross yield (t/ha/year)	233.8	8.9
Total net yield (t/ha/year)	76.0	



and 2/3 for tilapia.

- Catfish are fed with commercial pelleted feed.

- In the first month, fertilize the tilapia compartments weekly using urea and TSP at rates of 28 kg N and 7 kg P/ha/week.



Gross yield (t/ha/year)	233.8	8.9
Total net yield (t/ha/year)	76.0	
Total gross yield (t/ha/year)	84.0	

	Advantages	Disadvantages
Cage- or Pen-cum-pond integrated systems	<ul style="list-style-type: none"> Wastes derived from high protein diets in intensive fish culture can be reused as a valuable nutrient source to produce an additional crop of filter-feeding fish. Nutrients in wastes derived from intensive fish culture can be recovered. Nutrients contained in effluents, which are usually released directly or indirectly to the surrounding environment are thereby reduced. Both systems can be used in poly culture ponds to confine costly high protein diets to the target, high-value species. Both systems are environmental-friendly and suitable for small-scale farmers especially those with only one pond. 	<ul style="list-style-type: none"> The ratio of fed fish and filter-feeding fish is very important; an unbalanced ratio may cause high fish mortality.
Cage-cum-pond system	<ul style="list-style-type: none"> This system can be used in sub-tropical or temperate regions, where tropical fish species can make full use of growing seasons and facilitate harvesting without draining the ponds. Large fingerlings can be fattened with high protein diets in cages. Small fingerlings can be nursed with natural foods derived from cage wastes in open water (in the same pond where the cage is placed). 	<ul style="list-style-type: none"> The caged fish could be easily poached.
Pen-cum-pond system	<ul style="list-style-type: none"> It is simple, convenient and cheap compared with the cage-cum-pond system. 	<ul style="list-style-type: none"> The wastes derived from intensive culture may not circulate well to the semi-intensive culture section due to restriction of water flow through nets.

References

- Diana, J.S., C.K. Lin and Y. Yi. 1996. Timing of Supplemental Feeding. Journal of the World Aquaculture Society 27:410-419.
- Lin, C.K. 1990. Integrated Culture of Walking Catfish (*Clarias macrocephalus*) and tilapia (*Oreochromis niloticus*). In: R. Hirano and I. Hanyu (eds.), The Second Asian Fisheries Forum. Asian Fisheries Society, Manila, pp. 209-212.
- Lin, C.K. and J.S. Diana. 1995. Co-culture of Catfish (*Clarias macrocephalus* x *C. gariepinus*) and Tilapia (*Oreochromis niloticus*) in Ponds. Aquatic Living Resources 8:449-454.

- Yi, Y., C.K. Lin and J.S. Diana. 1996. Effects of Stocking Densities on Growth of Caged Adult Nile Tilapia (*Oreochromis niloticus*) and on Yield of Small Nile Tilapia in Open water in Earthen Ponds. *Aquaculture* 146:205-215.
- Yi, Y. and C.K. Lin, 2000. Integrated Cage Culture in Ponds: Concepts, Practice and Perspectives. In: I.C. Liao and C.K. Lin (eds.), *Proceedings of the First International Symposium on Cage Aquaculture in Asia*. Asian Fisheries Society, Manila, pp. 217-224.
- Yi, Y., C.K. Lin and J.S. Diana, in press. Integrated Recycle System for Catfish and Tilapia Culture. In: *Eighteenth Annual Technical Report*. Pond Dynamics/Aquaculture CRSP, Oregon State University, Corvallis.

Low-Cost Fertilization in Inland Pond Aquaculture



The introduction and/or improvement of aquaculture in small-scale agriculture systems is constrained by the limited availability of on-farm resources for use in fish culture. However, pond fertilization, using animal manure, has long been practiced in many Asian countries. The general goal of pond fertilization involves:

- increasing natural food production;
- optimizing nutrient utilization efficiency and cost efficiency; and
- maintaining a favorable growth environment for culture species.

Although fertilization of ponds with manure lowers fish production costs, the quality of available pond inputs is often poor. Intensification through supplementary fertilization of fishponds, with low-cost, off-farm inputs (i.e., chemical fertilizers) is one option to increase fish production of small-scale aquaculture. When added to fishponds, manure and chemical fertilizers may ultimately increase fish yields through soluble and/or particulate pathways.

Representative availability of nitrogen (N) and phosphorus (P) in various animal manure			
Animal manure	Moisture (%)	N (% dry weight basis)	P (% dry weight basis)
Poultry litter	28	2.8	1.2
Chicken (bagged)	38	2.0	3.0
Duck (fresh)	82	3.7	1.7
Buffalo (fresh)	77	1.7	0.1
Dairy cattle (fresh)	86	0.5	0.1
Swine (fresh)	89	0.6	0.2
Sheep (fresh)	77	1.4	0.2

Approximate nutrient contents of commonly used chemical fertilizers		
Chemical fertilizers	N (%)	P (%)
Urea	45	0
Ammonium nitrate	35	0
Superphosphate	0	10
Triple superphosphate (TSP)	0	20
Diammonium phosphate (DAP)	18	24

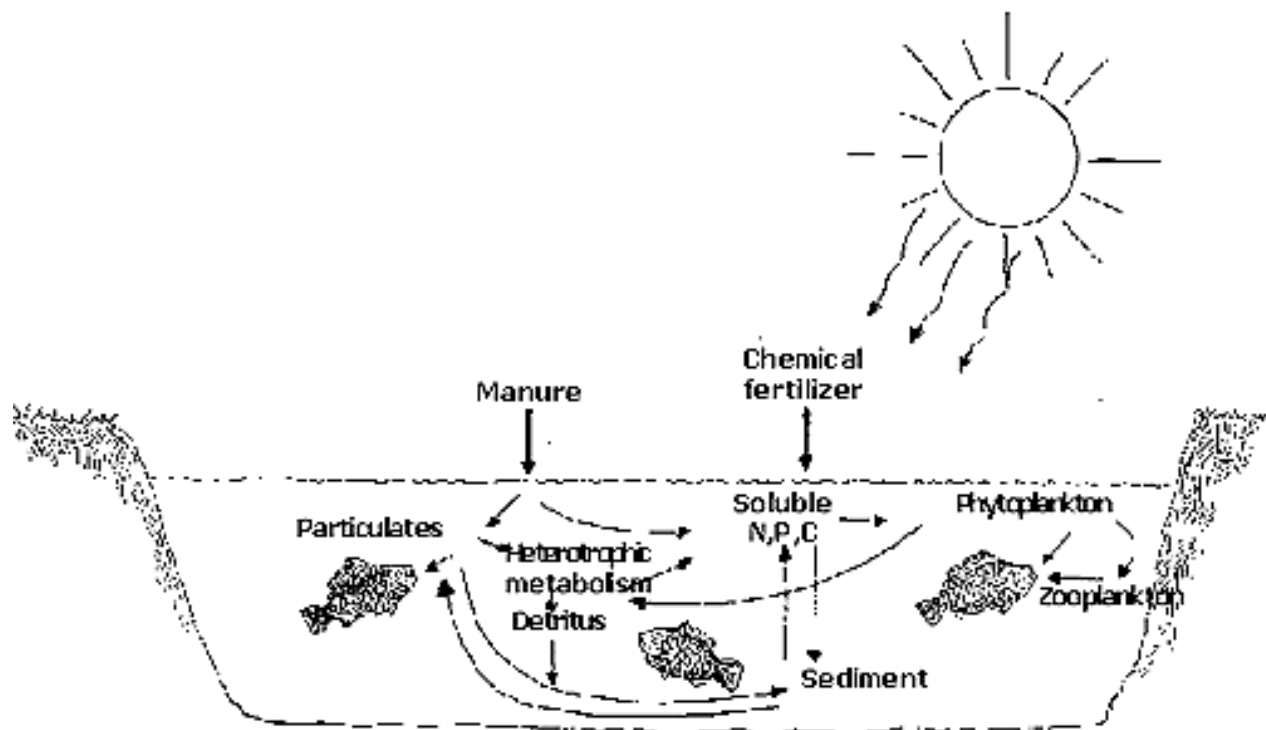

Low-cost fertilization strategies for Nile tilapia grow-out

For more than a decade, the Thailand Component of Pond Dynamics/Aquaculture Collaborative Research Support Program (PD/A CRSP) has developed various Nile tilapia pond culture strategies. The low-cost fertilization strategies include the use of:

- animal manure alone;
- chemical fertilizer alone; and
- the combination of animal manure and chemical fertilizers.

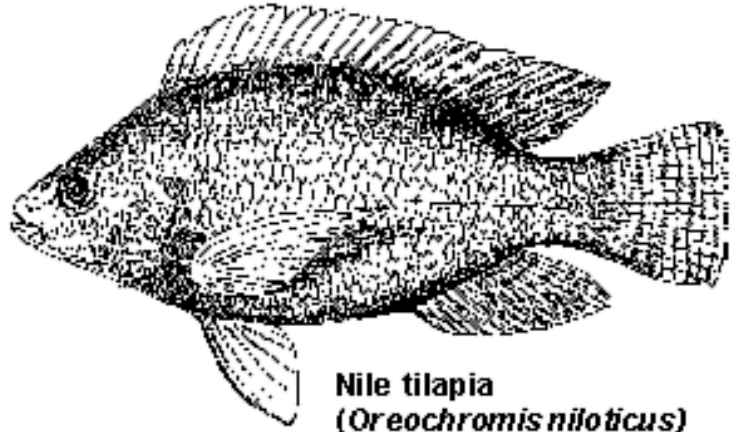

While the nutrient input rates and ratios are the most important factors, these fertilization strategies provide wide choices for small-scale farmers with various resources. Chicken manure (CM), urea and TSP have been chosen by PD/A CRSP as major sources for pond fertilization because they are widely available in many countries. The type of manure and chemical fertilizer is not of particular importance. The cost of nutrients and their availability are essential factors in selecting which source to choose in a particular locale. For farmers with sufficient resources, the selection of a strategy should be based on simple economic evaluation of the market prices of fish, manure and chemical fertilizers. The extended culture period of two to three months could result in larger fish sizes at harvest. Larger fish fetch higher prices resulting in an increase in net economic returns.

Example of production and economic return of sex-reversed male Nile tilapia cultured in ponds of 1m water column for two-month cycles

Strategies kg/ha/week	Stocking density (fish/sq m)	Final size (g)	Mean gross yield kg/ha/year	Mean net yield kg/ha/year	Net revenue (US\$/ha/year)
Chicken manure alone					
125	0.88	180	3,000	2,500	1,120
250	0.88	210	3,200	2,800	1,115
500	0.88	215	3,500	3,000	910
1000	0.88	240	3,900	3,500	550
500	1	180	2,900	2,300	620
500	2	110	3,500	2,300	760
500	3	75	3,600	1,900	-350
Chicken manure supplemented with chemical fertilizer					
CM Urea TSP					
225 + 51 + 6	1.76	180	5,000	4,700	915
175 + 54 + 12	1.76	170	5,100	4,800	920
125 + 56 + 19	1.76	205	6,200	5,900	1,360
75 + 59 + 25	1.76	255	7,600	7,300	1,955
25 + 61 + 32	1.76	190	5,500	5,200	900
Chemical fertilizer alone					
Urea (62)+TSP (35)	2-2.7	150	7,100	6,400	1,733

Note: Production is 10-15% lower when using mixed-sex Nile tilapia

Pond production of Nile tilapia often utilizes manure as part of its fertilization strategy. As fish yields increase with greater manure rates, it becomes important to balance organic and inorganic nutrient inputs to reduce the threat of deoxygenation.

Technical recommendations

Using results from on-station and on-farm trials in Northeast Thailand, the Asian Institute of Technology (AIT) has developed a package of technical recommendations for low-cost fertilization strategies for small-scale farmers.

Fertilization rates

- **Manure alone:** types and rates of manure depend on availability.
- **Manure supplemented with chemical fertilizer:** amount of chemical fertilizers is adjusted to the amount of applied manure to provide 28 kg N and 7 kg P/ha/week. The following formula is used.

Caution!



Excessive fertilization may cause deoxygenation which could lead to fishkills.

$$\text{N-fertilizer (kg/pond/week)} = \frac{[28 \cdot (\text{manure rate}) \times (\text{N\% in manure})] \times [\text{pond surface area(sq m)}]}{(\text{N\% in N-fertilizer}) \times (10,000 \text{ sq m})}$$

$$\text{P-fertilizer (kg/pond/week)} = \frac{[7 \cdot (\text{manure rate}) \times (\text{P\% in manure})] \times [\text{pond surface area(sq m)}]}{(\text{P\% in P-fertilizer}) \times (10,000 \text{ sq m})}$$

- **Chemical fertilizer alone:** the applied amount of chemical fertilizers will provide 28 kg N and 7 kg P/ha/week (urea at 62 kg/ha/week and TSP at 35 kg/ha/week). The required amount of chemical fertilizers can be determined using the above formulae. In acid-sulfate soils, the P input level might have to be raised four-fold.

Fertilization methods

- Manure is applied daily or weekly across the entire pond.
- N-fertilizers are applied weekly after dissolving in water.
- P-fertilizers are applied weekly after soaking overnight.

Liming

- Liming is applied to maintain alkalinity above 50 mg/l as CaCO₃.
- Liming is normally done at the beginning when using the "chemical fertilizer alone" strategy or when the pond soil is acidic.

Liming is applied at the following rates using different limes one week before pond filling	
Agricultural lime (CaCO₃)	1000-2000 kg/ha
Quicklime (CaO)	600-1200 kg/ha
Hydrated lime [Ca(OH)₂]	750-1500 kg/ha
Dolomite [CaMg(CO₃)₂]	900-1800 kg/ha

Stocking

- Fish should be stocked one to two weeks after pond filling.
- Stocking density ranges from 0.5 to 3 fish/sq m (5,000 to 30,000 fish/ha), depending on fertilization rates.
- It is better to nurse fry to around 5 g (6-8 cm) in hapas prior to stocking.

Pond management

- Water exchange and aeration are not needed.
- Water is added weekly to compensate for loss due to evaporation and seepage to maintain at least 1 m water column.

Conclusion

Low-cost fertilization strategies are suitable for small-scale farmers engaged in tropical pond aquaculture. Rates of manure and chemical fertilizers may be adjusted based on local conditions, availability of nutrients and cost.

References

Diana, J.S., C.K. Lin and K. Jaiyen. 1994. Supplemental Feeding of Tilapia in Fertilized Ponds. *Journal of World Aquaculture Society*. 25(4):497-506.

Knud-Hansen, C.F. 1998. Pond Fertilization: Ecological Approach and Practical Applications. Pond Dynamics/Aquaculture CRSP, Oregon State University, Corvallis, 155 p.

Knud-Hansen, C.F., T.R. Batterson, C.D. McNabb and K. Jaiyen. 1991. Yields of Nile Tilapia (*Oreochromis niloticus*) in Fish Ponds in Thailand Using Chicken Manure Supplemented with Nitrogen and Phosphorus. In: H.S. Eгна, J. Bowman, and M. McNamara (eds.), Eighth Annual Administrative Report, Pond Dynamics/Aquaculture CRSP, Oregon State University, Corvallis, Oregon, pp. 54-62.

Lin, C.K., D.R. Teichert-Coddington, B.W. Green and K.L. Veverica. 1997. Fertilization Regimes. In: H.Eгна and C.E. Boyd (eds.), Dynamics of Pond Aquaculture. CRC Press, Boca Raton, pp. 73-107.

Pant, J., S.M. Shrestha, C.K. Lin, H.Demaine and J.S. Diana. 1999. High-input Green Water On-farm Trials in Northeast Thailand. In: K. McElwee, D. Burke, M. Niles and H. Eгна (eds.), Sixteenth Annual Technical Report. Pond Dynamics/Aquaculture CRSP, Oregon State University, Corvallis, pp. 171-181.

Yi, Y. and C.K. Lin. 2000. Analyses of Various Inputs for Pond Culture of Nile tilapia (*Oreochromis niloticus*): Profitability and Potential Environmental Impacts. In: K. Fitzsimmons and J.C. Filho (eds.), Proceedings from the Fifth International Symposium on Tilapia Aquaculture, pp. 247-257.

Prepared by:

Yang Yi and C. Kwei Lin

Culture of Fish Food Organisms and Biofertilizers

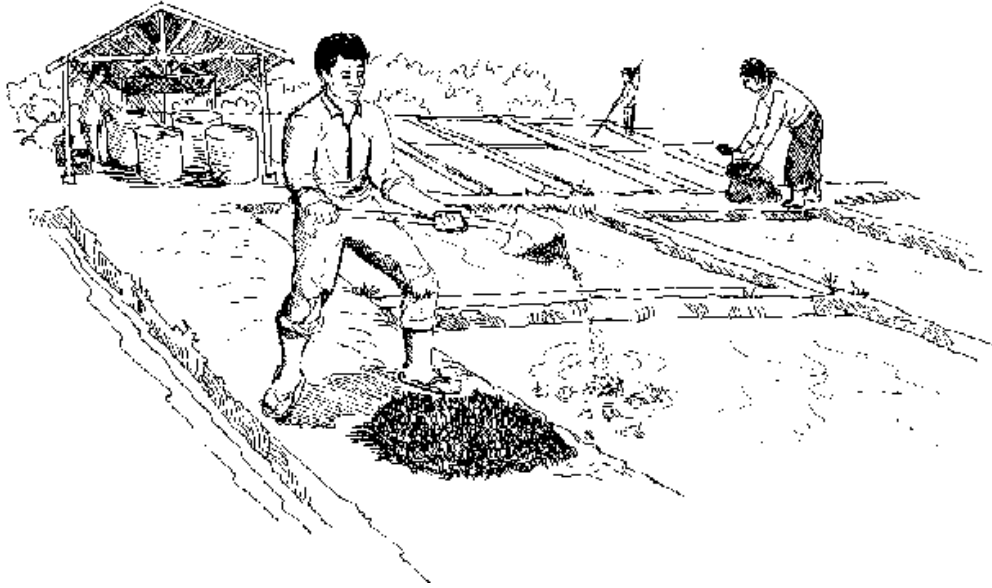

Intensification of aquaculture exerts pressure on the trophic potentials of an aquatic system. Fertilization and planned introduction of fish food organisms are two measures employed to enhance the natural productivity of a habitat. This is of great importance in the hatching and production stages of several fish and shellfish species.

Fish food organisms are the different groups of plankton whose growth can be enhanced through the application of fertilizers. Biofertilizers are biotic agents like bacteria and algae that carry out functions like fixing atmospheric nitrogen. They can therefore substitute for chemical fertilizers.

Fish food in ponds

Plankton are the basic component in the food spectrum of fish in aquaculture ponds. Phytoplankton in freshwater ponds are blue-green algae (*Cyanophyceae*), green algae (*Chlorophyceae*), diatoms (*Bacillariophyceae*) and dinoflagellates (*Dinophyceae*). The common groups of zooplankton are protozoans, rotifers, cladocerans and copepods. Most fish and shellfish species used in pond culture are filter-feeding herbivores or detritivores, depending on the abundance of plankters.

Culture of fish food organisms

Fish food organisms like *Chlorella*, *Scenedesmus*, *Dunaliella*, *Brachionus*, *Moina* and *Artemia* are cultured as feed for hatchery systems. In-pond productivity enhancement measures can be undertaken, including varying proportions of organic and inorganic fertilizers, provision of periphytic substrates (polythene sheets and bamboo mats). The development of biofilm and periphyton provides additional food biomass for the fish. A 10-15% increase in fish production can be achieved through the inclusion and enhancement of fish food organisms.

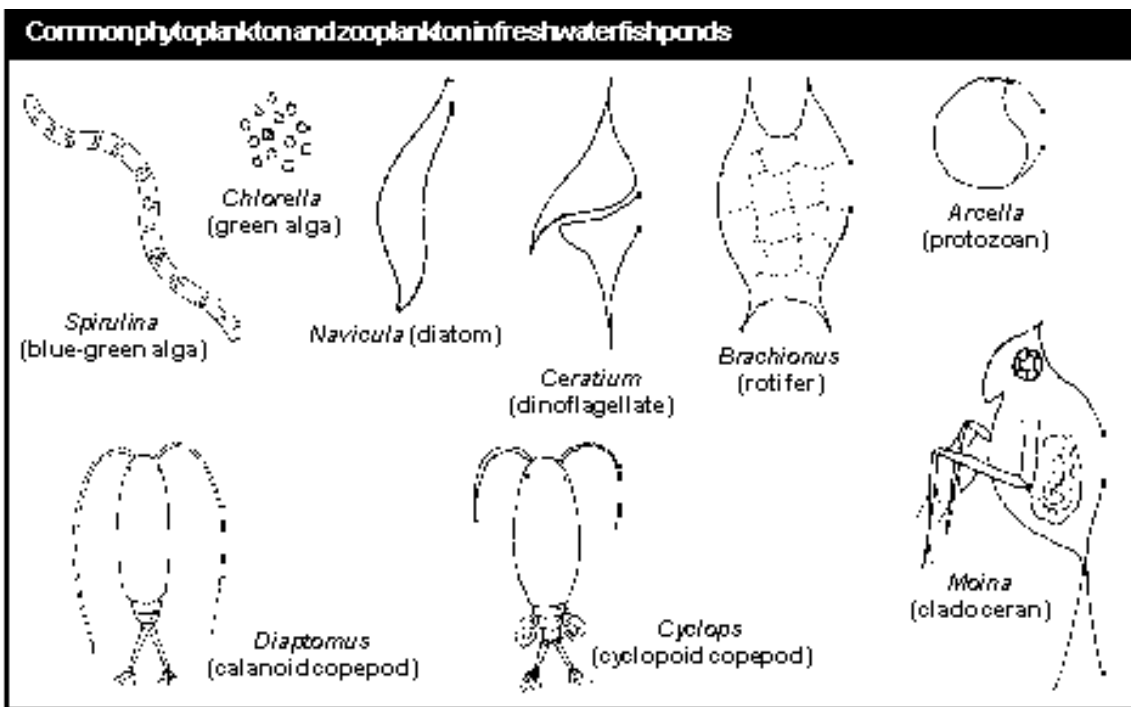

Culture of high-value algae like *Spirulina*, which commands a market price of up to US\$25/kg, has become a secondary aquaculture industry, on the lines of ornamental fish culture. In India, cooperative units of *Spirulina* cultivation involving rural women have been set up. A nodal facility provides the nutrient inputs. The produce from the satellite marketing units are collected. Groups of 25-30 women undertake the lgal culture in four to six cement vats (3 m x 1.5 m x 0.6 m) using the algal starter material and the nutrient inputs that they receive from nodal facilities. Pure cultures are maintained at the central unit and are replenished whenever needed.

Spirulina

Spirulina (*S. platensis*, *S. fusiformis*) is a blue-green alga known for its protein level (62-71%). It is likewise known for its beta-carotene (1.7 g/kg), a precursor of vitamin A. It possesses a digestibility of 84% and net protein utilization of 61%. It is an important dietary component of valued fish and shellfish species like ornamental fish and prawns. It is also of therapeutic value to humans.

With lab-scale cultures of *Spirulina* obtained in Zarrouk's medium (having a high level of bicarbonate), the commercial cultivation is carried out in a network of cement raceways to prevent algal accumulation at the surface. The outdoor cultivation parameters are:

- raceways (length-breadth ratio 1.5:1) preferably with a mid-rib for facilitating water circulation;
- culture medium depth 15-20 cm;
- flow rate 20 cm/sec;
- temperature 25-35°C;
- pH 9-11;
- hardness 120-150 mg/l; and
- light intensity 20-30 k lux.

Zarrouk's medium for indoor cultures

	g/l
Sodium bicarbonate	18.00
Dipotassium hydrogen phosphate	0.50
Sodium carbonate	4.00
Sodium chloride	1.00
Sodium nitrate	2.50
Magnesium sulphate	0.20
Ferrous sulphate	0.01
Potassium sulphate	1.00
Calcium chloride	0.04
EDTA	0.08

Trace quantities of manganese chloride, sodium molybdate, zinc sulphate, sodium tungstate, titanium sulphate and cobalt nitrate.



Azolla as a biofertilizer in aquaculture

The significance of biological nitrogen fixing in aquatic systems has brought out the usefulness of biofertilization. *Azolla* is a floating aquatic fern, fixing atmospheric nitrogen through the cyanobacterium, *Anabaena azollae*. Its high nitrogen-fixing capacity, rapid multiplication and decomposition rates resulting in quick release of nutrients have made it an ideal nutrient input in farming systems.

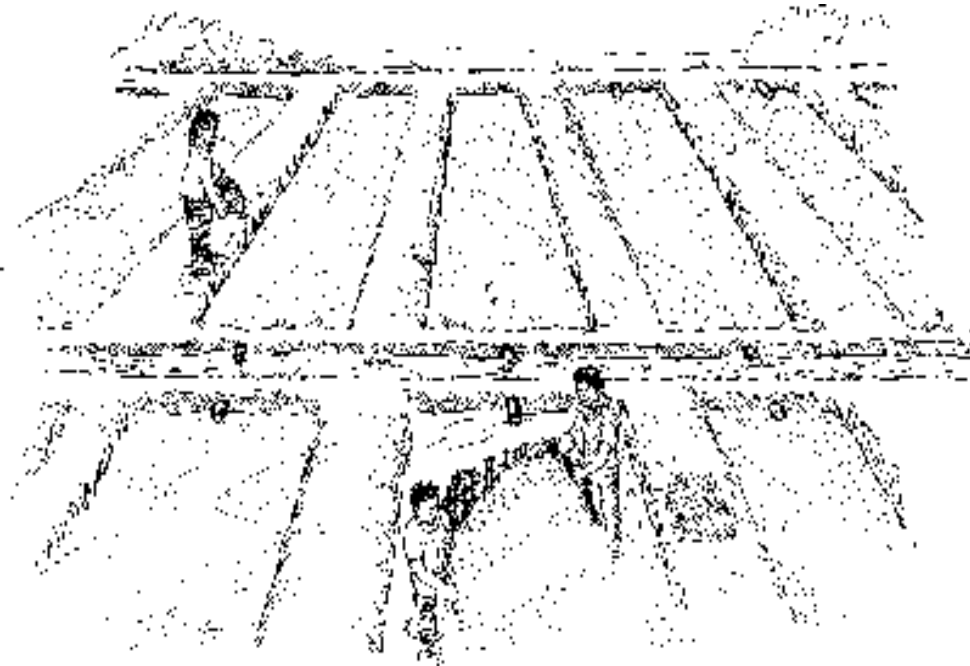

The normal doubling time of *Azolla* is three days. A kilo of phosphorus applied during its culture results in 4-5 kg of nitrogen (i.e., 1.5-2 tons of fresh biomass). With a dry weight range of 4.8-7.1% among different species, the nitrogen and carbon contents are 1.9-5.3% and 41.5-45.3%, respectively.

While *Azolla* is grown as a green manure before rice transplantation or as a

dual crop in agriculture, it can be cultivated in earthen raceways and applied periodically to fish ponds.

***Azolla* culture in earthen raceways**

The culture system comprises a network of earthen raceways (10-15 m x 1.5-2 m x 0.3 m), with water supply and drainage facilities. The operation in each raceway consists of:

- application of *Azolla* inoculum to cover one-third the water surface (400 g/sq m);
- phosphatic fertilizer (3 g/sq m);
- maintenance of 5-10 cm of water depth; and
- harvest in a week's time.

The produce is about 1-1.5 kg/sq m in this period and, for continuous culture, a third of the biomass is left as inoculum for the next cycle.

The suggested application rate of *Azolla* to meet the nutrient requirements in carp polyculture (and substitute for chemical nitrogenous fertilizer) is 40 tons/ha/year. This requires an area of about 800 sq m, a unit that could be taken up as a subsidiary farming activity. Along with the environmental benefits, a saving of up to 30-35% over

the traditional manuring practices is estimated.

A related aspect is the cultivation of other duckweeds that do not fix atmospheric nitrogen, hence, requiring addition of both nitrogen and phosphorus as nutrient inputs. Different species of *Spirodela*, *Lemna* and *Wolffia* are candidate species, as they have high growth rates of 200-300 g/sq m/day. With high nutrient absorption rates, their doubling time is only two to three days. They are also useful in the bioremediation of effluents in both domestic and agro-based industries (e. g., dairy effluent) and serve as inputs for fish farming systems.

Feeds in Small-Scale Aquaculture



Carp and tilapia are dominant species in freshwater fish culture in many Asian countries. Majority of carps and tilapias are produced by utilizing natural foods resulting from proper pond fertilization, often supplemented by artificial feeds to enhance fish yield and raise fish to a larger size than is possible with natural foods. Artificial feeds range from farm products such as grass and rice bran to farm-made, formulated feeds and commercial feeds. The choice of artificial feeds depends mainly on the cost and availability of resources to small-scale farmers.

Types and protein contents of artificial feeds

There are many types of artificial feeds for fish culture. The nutritional value of different artificial feeds depends on the palatability, digestibility and nutrient composition. The crude protein (CP) content (% of dry matter) of a specific feed varies because of many factors. Feed conversion ratio (FCR) is the wet weight (kg) of feed required to grow one kg of fish, depending upon the feed quality, moisture, cultured species, culture system and so on.

A. Aquatic and terrestrial plants

Plants are one of the most widely available fish feed sources locally. They can be used fresh or dried or powdered for fish feeds.

Commonly used aquatic plants (CP 15-35%, FCR 20-100)

- Duckweed (*Lemna* spp.)
- Giant duckweed (*Spirodela* spp.)
- Water egg (*Wolffia* spp.)
- Aquatic fern (*Azolla* spp.)
- Water hyacinth (*Eichhornia crassipes*) – should be used in combination with other feed ingredients and should not exceed more than 10% (dry weight) by weight
- Pond weed (*Potamogeton* spp.)
- Water spinach (*Ipomea aquatica*)

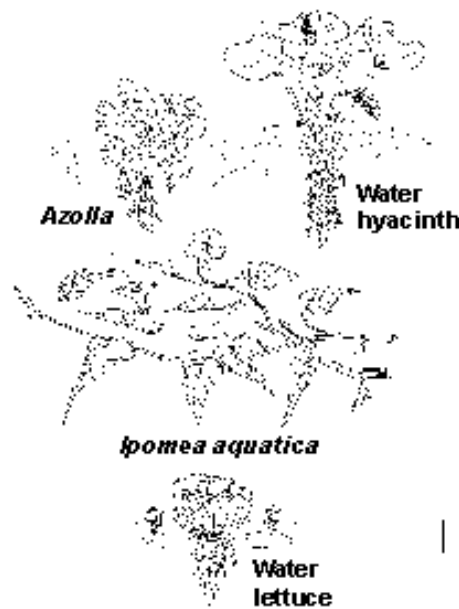

- Alligator weed (*Alternanthera philoxeroides*)
- Water lettuce (*Pistia stratiotes*)
- Salvinia (*Salvinia* spp.)
- Reed-mace (*Typha latifolia*)
- Tape grass (*Vallisneria spiralis*)
- Hydrilla (*Hydrilla verticillata*)

Commonly used terrestrial plants (CP 10-30%, FCR 20-50)

- Napier or Elephant grass (*Pennisetum* spp.)
- Ryegrass (*Lolium multiflorum*)
- English rye (*Lolium perenne*)
- Alfalfa (*Medicago sativa*)
- Red clover (*Trifolium pratense*)
- White clover (*Trifolium repens*)
- Sudan grass (*Sorghum vulgare* var. *sudanese*)
- Guinea grass (*Panicum maximum* Jacq.)
- Para grass (*Brachiaria mutica*)
- Lalang grass (*Imperata ruginacea*)
- Star grass (*Cynodon plectostachyus*)
- Barnyard grass (*Echinochloa crusgalli*)
- Sweet potato (*Ipomea batatas*)
- Wheat (*Triticum* spp.)
- Oak (*Avena sativa*)

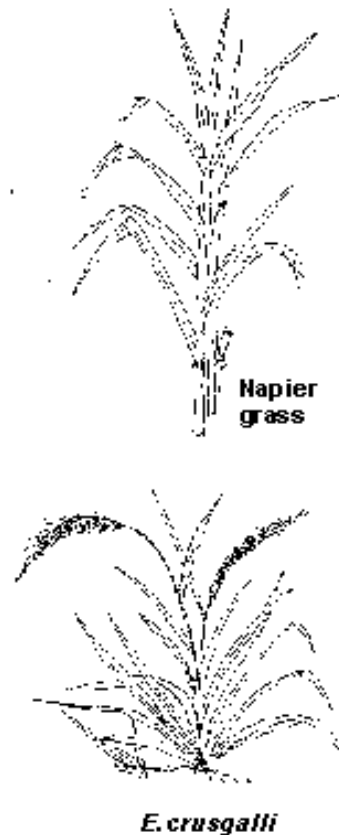

- Barley (*Hordeum* spp.)
- Maize (*Zea mays*)
- Fresh rice straw (*Oryza sativa*)
- Sorghum (*Sorghum* spp.)
- Ramie leaves (*Boehmeria nivea*)
- Canna leaves (*Canna edulis*)
- Pumpkin vines (*Cucurbita* spp.)
- Velvet bean vines (*Mucuna* spp.)
- Cassava leave and tuber (*Manihot esculenta*)
- Bean stalk leaves and seed
- Leaves of fruit trees such as papaya (*Carica papaya*) and banana (*Musa* spp.)
- Vegetables
- Leaves and stems of leguminous plants, gourds, melons. etc.

B. Aquatic animals and terrestrial-based live feeds (CP 40-85%, FCR 10-80)

Aquatic animal feeds and terrestrial-based live feeds are considered to be nutritionally complete. Terrestrial-based live feeds such as earthworms and maggots can be produced on-farm using various organic wastes. Some examples are:

- mollusks such as snails and clams;

- insects such as silkworm larvae (*Bombyx mori*), soldier fly larvae (*Hermetia illucens*) and termites (*Reticulo termes santonesis* and *Zootermopsis nevadensis*);
- small crustaceans such as wild small shrimp; and
- earthworms and maggot

C. Plant processing by-products

The most common plant feeds from various agricultural by-products are listed below.

Deoiled cakes and meals

Deoiled cakes and meals are major sources of plant proteins (CP 20-50%, FCR 3-6).

- Beans
- Soybean
- Peanut
- Sesame
- Cashew
- Cocoa
- Coconut
- Oil palm
- Linseed
- Mustard
- Sunflower
- Cottonseed
- Rapeseed
- Cannabis
- Bran

Beans (CP 25-36%, FCR 4-8)

- Soybean
- Broad bean
- Red bean
- Pea
- Cowpea

Grains and brans

Commonly used starch feed (CP 8-27%, FCR 3-4)

- Corn
- Sorghum
- Barley
- Broken rice
- Rice bran
- Wheat bran
- Wheatflour sweepings

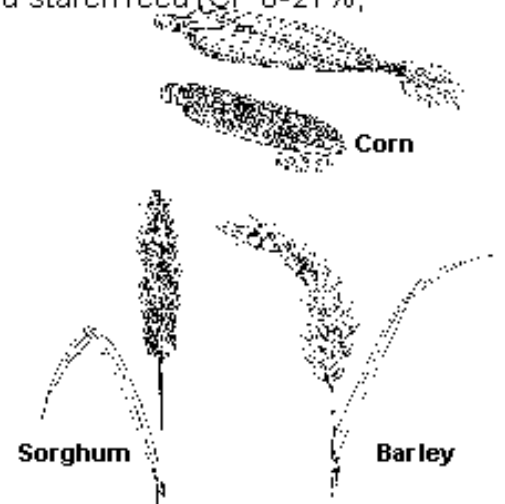

D. Animal processing by-products (CP 40-85%, FCR 1.5-4)

Animal feeds with high nutritional values are made from a variety of sources, such as by-products from processing factories. Major animal protein feeds include:

- Fish meal
- Bone/meat meal
- Blood meal
- Silkworm pupae meal

- Feather meal
- Food yeasts

E. Industrial wastes

Organic waste materials from industries such as food processing, wine and beer manufacturing and water processing are widely used directly as fish feeds or as a substrate to produce living organisms for fish feeds.

F. Formulated feeds (CP 18-50%, FCR 1.5-4.0)

Formulated feeds are composed of several materials in various proportions. The ingredients of formulated feeds complement each other and increase feeding efficiency.

G. Commercial feeds (CP 18-40%, FCR 1.0-2.0)

Commercial feeds are nutritionally complete feeds such as pellets.

Feed preparation

Existing techniques of on-farm feed preparation for carps and tilapias are simple.



.Most terrestrial-based live feeds are added directly to fish ponds.

.Snails and clams are crushed before being offered to the fish.

.Grass and leaves are usually chopped when fish are small or ground for rearing fry and fingerlings or grow-out fish of both filtering and omnivorous species. On the other hand, larger fish (>50 g) are fed directly.

.Water lettuce, water hyacinth and alligator weeds must be treated before being used for

feeding.

– Minced

– Fermented: Mix 100 kg plants with 3-4 kg rice bran and 0.5 kg yeast; seal in containers and store for two days at 26°C.

– Elimination of saponin: Alligator weed contains saponin, which is toxic to fish. The toxicity can

be eliminated by adding two to five percent table salt during fermentation.

– Mashed: These plants can be mashed into paste, which is an appropriate feed for fish fry because mesophyll cells in the paste are the same size as plankton.

- If dry ingredients are used, a well ground mixture maybe offered in feeding bags or simply dispersed throughout the pond.
- A reduction in feed waste can be achieved by cooking carbohydrate sources, such as cassava tubers, and mixing other ingredients with the gelatinized starch. This mixture can either be directly fed as a wet dough or pelleted by a simple extrusion process.
- Minerals and vitamins can be added when preparing feeds. For example, the addition of 2% di-calcium phosphate can increase efficiency of soy bean-based feed. It is a popular practice in China and India to use common salt in preparing feeds. The addition of vitamins can increase fish yields by 15-20% when fish stocking density is above 0.6 fish/sq m.
- On-farm prepared pellets could be sundried and stored for future use.

Some examples of protein ingredients for producing formulated feeds, their protein contents and FCR for carps and tilapias			
Protein ingredients	Protein content (%)	FCR	Species
Silkworm pupae + rice bran	25	3.0	Carp
Silkworm pupae + peanut cake + rice bran	28	3.7	Catla
Soybean meal + peanut cake + rice bran	27	3.6	
Fish meal + peanut cake + rice bran	30	2.0	
Fish meal + bean cake + silkworm pupae + peanut cake + wheat	18.2	3.6	Grass carp
Fish meal + bean cake + wheat bran + deoiled cake + wheat + barley	26.9	2.3	
Fish meal + bean cake + corn + peanut cake + wheat	24.7	1.5	
Fish meal + bean cake + wheat bran + deoiled cake	27.8	1.9	
Fish meal + bean cake + deoiled cake + rice bran + food yeasts	39.1	2.5	Black carp
Silkworm pupae + deoiled cake + barley + bone powder	26.2	2.7	
Bean cake + wheat bran + deoiled cake	30.9	2.1	
Fish meal + bean cake + silkworm pupae + com + wheat + rice bran + bone powder	39	1.8	Common carp
Fish meal + bean cake + barley	43.4	1.8	
Silkworm pupae + wheat bran + deoiled cake	30	2.5	
Fish meal + bean cake + wheat bran + barley + mussel powder	31.4	1.9	
Fish meal + cassava	30	1.5	Nile tilapia
Soybean meal + cassava	30	1.5	
Fish meal + bean cake + silkworm pupae + com + barley + tree leave	34.6	2.0	Tilapia
Bean cake + silkworm pupae + corn + mussel powder	22.6	1.9	
Fish meal + bean cake + silkworm pupae	25.5	1.8	
Fish meal + bean cake + silkworm pupae + corn	19.4	2.1	

Feeding

The required feeding rates and feed quantity for a particular fish pond depend on certain

factors.

- Feed quality
- Cultured species
- Stocking density
- Fish size
- Nutrient inputs of manure and chemical fertilizers
- Pond history



Quantity can be calculated based on the expected net fish yield and FCR of the particular type of feed. The daily feeding rate is made equal to the percent increase in body weight of fish in the pond per day, times the existing biomass. In practical terms, these data are estimated from past years' experiences on the increase in fish biomass.

The dry matter loading rate in pond culture directly influences the morning dissolved oxygen concentrations and ammonia toxicity levels. The upper dry matter loading rate for short duration (three to six months) tilapia/carp polyculture systems is approximately 100 kg feed (dry matter)/ha/day.

In well fertilized ponds, supplemental feeding is generally needed during the last three months to fatten fish for better market prices. For Nile tilapia (*Oreochromis niloticus*), pond culture with fertilization rates of 28 kg N and 7 kg P/ha/week supplemental feeding is not needed before fish reach 150 g.

Since carps and tilapia generally have relatively low market prices, a cost-effective feeding regime depends mainly on:

- careful selection of feedstuff and ingredients;
- utilization of an optimum feed formulation;
- selection of multi-purpose equipment for feed preparation;
- optimization of feed dispersion; and
- minimizing feed waste.

For small-scale farmers with poor resources, the appropriate feeding strategy is to use available feed as supplement in fertilized systems rather than as an ingredient for formulated feeds.

References

Diana, J.S., C.K. Lin and Y. Yi. 1996. Timing of Supplemental Feeding for Tilapia Production. *Journal of the World Aquaculture Society*, 27(4):410-419.

Li, S.F. and J. Mathias (eds.). 1994. *Freshwater Fish Culture in China: Principles and Practice*. Elsevier Science, Amsterdam, The Netherlands. 445 pp.

Little, D and J. Muir. 1987. *A Guide To Integrated Warm Water Aquaculture*. Institute of Aquaculture, University of Stirling, Scotland. 238 pp.

Yakupitiyage, A. 1992. On-farm Feed Preparation and Feeding Strategies for Carps and Tilapias. In: M.B. New, A.G.J. Tacon and I. Csavas (eds.), *Farm-Made Aqua Feeds. Proceeding of The FAO/AADCP Regional Expert Consultation on Farm-Made Aqua Feeds. 14-18 December 1992*, FAO Regional Office, Bangkok, Thailand. pp. 87-100.

Decentralized Seed Production Strategy for the Development of Small-Scale Aquaculture

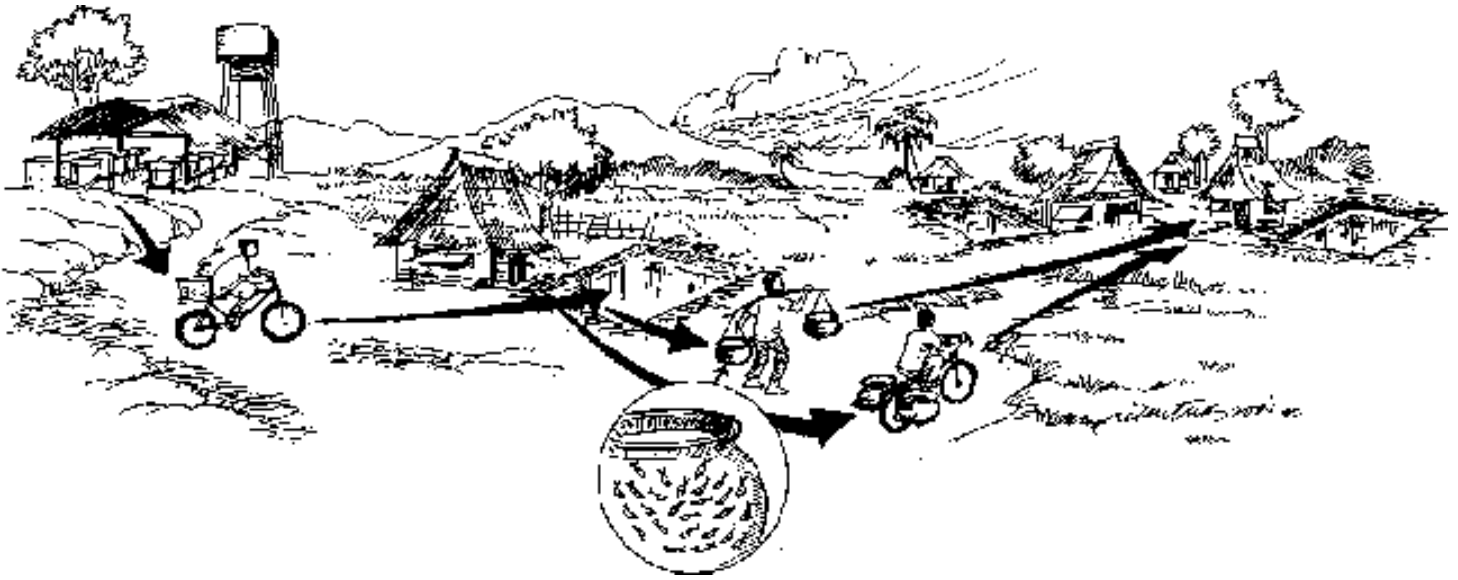

Good quality fish seed in the right quantity is one of the most critical inputs for aquaculture. Since most of the cultivable species do not breed naturally in confined water, aquaculture in the early days depended exclusively on seed collected from wild sources. With the popularization of aquaculture:

- the demand for seed increased multifold;
- the price of seed increased making seed collection a lucrative activity; and
- seed collection activity reached a stage where it threatened riverine fisheries.

Most of these issues were resolved when induced breeding was successfully demonstrated in Bangladesh in 1966. Taking advantage of this technology, four large regional hatcheries were established in the early 1980s.

Centralized to decentralized production

Soon, the regional hatcheries could no longer cope with the growing demand for seed. There were also difficulties in seed distribution to different parts of the country. To ease the situation, the government established over a hundred seed production farms in areas with the greatest potential for aquaculture.

Emergence of mini hatcheries

Pond aquaculture contributes over 80% of the total aquaculture production in Bangladesh. Except for community ponds, most of these are homestead ponds ranging from 0.05 - 0.25 ha, scattered throughout the country. Since the ponds are small, individual seed requirements are also small. Hence, long distance transport of seed was not only troublesome but also costly and risky. The unavailability of seed locally was a major constraint in harnessing the full potential of small-scale aquaculture. To address the problem, the government encouraged

farmers and rural entrepreneurs to establish low cost mini-hatcheries. At present, about 90% of the seeds are produced by 713 small private hatcheries, some of which are owned by NGOs. Government-owned hatcheries now account for only less than 5% of the total fry production. Most private hatcheries are small.

The establishment of small hatcheries increased seed production. Distribution across the country was impressive and now, the collection of seed from natural sources has become negligible.

Advantages of decentralized seed production

- Local and year-round availability of seed.
- Low cost, due to elimination of transport expenses.
- Emergence of a large number of local seed rearers and seed vendors in rural areas creating additional livelihood opportunities.
- More options for buying seed.
- Accessibility of seeds encourages farmers to take up aquaculture as an additional livelihood.
- Reduced mortality of fry and fingerlings.
- Genetic diversity of local breeds maintained.
- Reduced dependency of farmers on big/central hatcheries for seed.
- Government seed farms able to concentrate on other important roles like serving as brood bank, maintaining genetic quality of farmed species, on-farm genetic conservation, participating in genetic improvement conservation program with the Bangladesh Fisheries Research Institute (BFRI), etc.

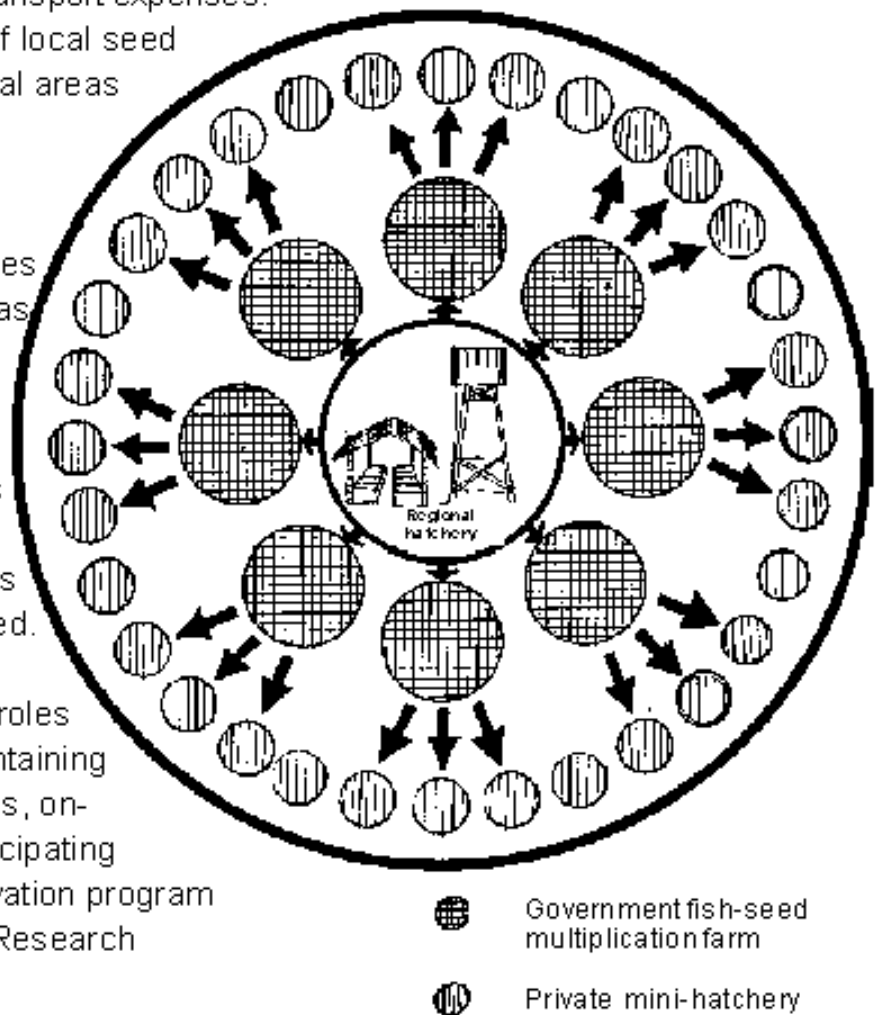

Species used for breeding in mini-hatcheries

Usually major carps are widely cultured in Bangladesh and other countries of South Asia.

Location

Most of the mini-hatcheries are located in flood-free areas where there is a high pond concentration and are accessible by road and rail.

Physical facilities required for a mini-hatchery

A small fish hatchery is composed of the following:

1. **Overhead water tank** capable of running the operation for two to three hours once it is filled. On the top of the tank, perforated trays are placed for water oxygenation.

2. A **shallow tube well** is a minimum requirement for supplying water to a hatchery. A deep tube well is used for bigger hatcheries.

3. A **circular spawning/breeding tank** 4-5 m in diameter and 1-1.25 m deep. This tank is fitted with a water inlet, outlet and egg collection facilities. Fishes are kept here for breeding purposes.

4. **Hatching jar**, which are cone-shaped cemented structures fitted with a water supply inlet at the bottom. A ball is placed at the opening of the inlet line to prevent fish eggs from entering the water supply line. An outlet exists at the top of the jar. A fine-meshed net is warped around the top of the jar to avoid losses of eggs or hatchlings. Eggs are placed in this jar at the rate of 2.5 liters. Capacity of the hatching jar is about 300-450 liters. The number of hatching jars depends upon the local demand for seed.

5. **Holding tank**, a rectangular tank 3-4 m long, 1 m wide and 1 m deep. Broods are kept here prior to injection for spawning.

Age and size of brood fish used for breeding in the hatcheries

The following are usual species being used in the hatcheries including their minimum age and weight

Species	Minimum age (year)	Minimum weight (kg)
Catla (<i>Catla catla</i>)	2+	3.0+
Rohu (<i>Labeo rohita</i>)	2	1.5+
Mrigal (<i>Cirrhinus mrigala</i>)	2	1.0+
Calbasu (<i>Labeo calbasu</i>)	2	1.0+
Silver carp (<i>Hypophthalmichthys molitrix</i>)	2+	2.5+
Grass carp (<i>Ctenopharyngodon idella</i>)	2+	2.5+
Bighead carp (<i>Aristichthys nobilis</i>)	2+	2.5+
Common carp [<i>Cyprinus carpio</i> (var. <i>comunis</i>)]	1+	1.5+
Mirror carp [<i>Cyprinus carpio</i> (var. <i>specularis</i>)]	1+	1.5+
Silver barb (<i>Barbodes gonionotus</i>)	1	0.4+
Pangas (<i>Pangasius eutchall</i>)	2	1.5+

Fish seed (hatchling) production trend in Bangladesh

Year	Production		
	From natural sources (kg)	Produced in hatcheries (kg)	Contribution of private hatcheries (%)
1990	5128	13014	30
1991	6855	22170	50
1992	9342	33072	55
1993	4913	43047	65
1994	5871	49000	75
1995	9144	72000	80
1996	2399	116212	87
1997	2824	117500	87
1998	2885	118100	88
1999	2600	169000	90

1 kg of spawn counts 350,000 - 400,000 spawn (4 days old)

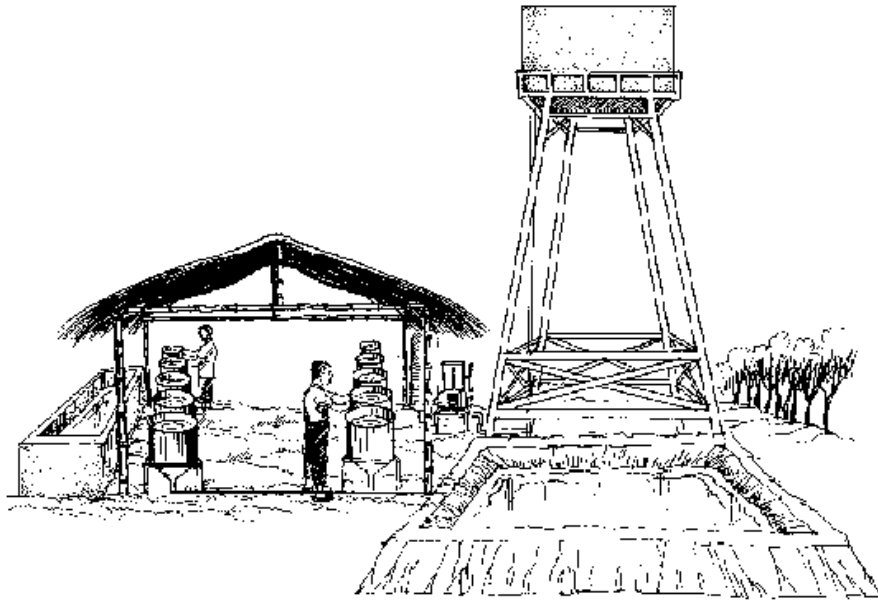

6. **Shed**, made of cheap material such as bamboo and straw to cover the whole structure (except the overhead tank)

7. **Brood fish** maintained in adjacent ponds owned or leased, or collected from natural sources as per the production capacity of the hatchery. Usually, existing and nearby ponds are used as brood ponds.

Rearing of broodstock

Broods of major carp are maintained at a density of 2000-2500 kg/ha in the ponds. Usually silver carp and bighead carp are not reared along with catla to avoid food competition. Typically, hatchery owners maintain only about 10% of their total requirement of broods. They breed one female two to three times in a season. In general, the small hatchery operators need about 10-12 kg (combined weight) of broodstock (carps) to produce 1 kg of spawn (350,000 - 600,000). This includes both male and female brooders in a ratio of 2:1.

Distribution/sale of spawn

Farmers buy the hatchlings from a small-scale hatchery and rear them up to fingerling stage for sale. In most cases, they use the homestead ponds or road side seasonal ditches to rear the seed. Ponds used to nurse the seed are either owned or leased. Large-scale hatchery owners distribute their products (hatchlings) all over the country. Large hatcheries usually maintain a good number of nursery and rearing ponds and many poor people are employed in fry rearing.

Hatchlings are sold at different prices depending on species. Catla and mrigal are highest and lowest priced species, respectively. Hatchlings are sold at rates ranging from US\$20.00 to US\$100.00/kg. Prices of spawn vary between peak and lean breeding periods: prices are high during the early part of the season and low towards the end

Important consideration

Many hatchery operators do not follow guidelines for maintaining the genetic quality of the fish resulting in instances of inbreeding. Hatchery operators should have at least half of their brood stock collected from natural sources.



of the season.

Seed production strategy for the development of small-holder rural aquaculture

The strategy of decentralized seed production by promoting the establishment of privately-owned mini-hatcheries has created an immense impact on the development of small-scale aquaculture and culture-based fisheries. Fish seeds (spawn, fry and fingerlings) are now easily and widely available throughout the country. A large number of resource poor rural families depend on raising spawn (up to fry) and fingerlings for their livelihood while many others work as fish seed vendors.

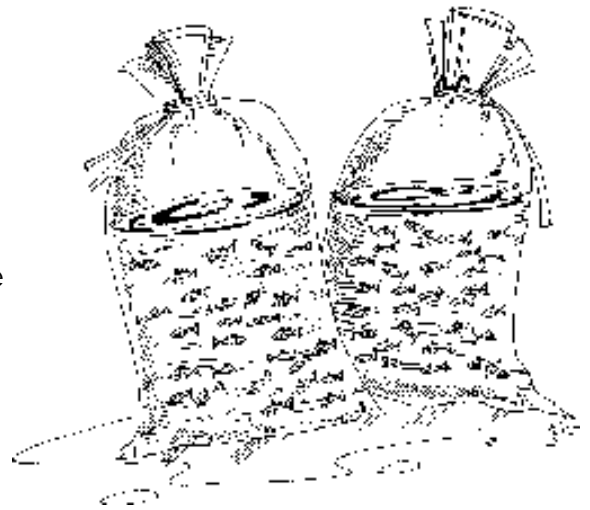

Conclusion

Accessibility of good quality seeds at the right time and in desired quantities has also contributed to the development of small-scale aquaculture and enhanced fisheries. Just as important probably, is the employment-generating potential of these seed production ventures.

Small-Scale Eel Culture: Its Relevance for Rural Households

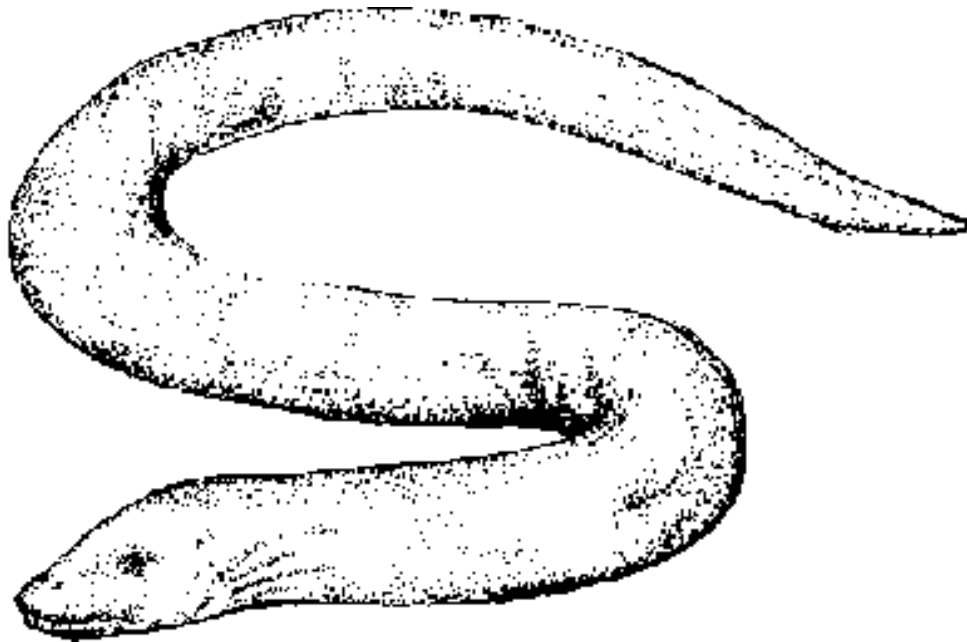

The eel has always been an odd subject. Many people regard it as an undesirable snake-like, mysterious animal. However, the economic importance of eels to a number of countries in the world is undisputed, at least for *Anguilla* eels.

Eel culture can be undertaken with a minimum investment, using locally available and cheap resources. Eels are long snake-like fish with a smooth, slimy, scaleless skin. There are hundreds of varieties of eels. *Monopterus albus* (rice field eel but in some literature also known as swamp eel), which disappeared locally for unknown reasons, was reintroduced by the International Institute of Rural Reconstruction (IIRR) in late 80s in the Philippines. Many farmers are raising this species for food.

Comparative nutritive value of selected foods		
Sources	Calories	Protein (g/100g of material)
Eel	303.0	14.0
Fish (general)	125.0	18.0
Shrimp	90.0	16.0
Chickenmeat	110.0	20.0
Beef	301.0	17.5
Egg	160.0	13.5
Milk	62.5	3.5

The technology described in this paper is based on several years of successful practice by farmers in Indonesia, as well as on-station and on-farm trials in the Philippines. It has also been successfully practiced in China and *Monopterus* eels, either caught from the wild or raised, are sold for a high price (US\$3-4).

The genus *Monopterus* has six species and is found only in Asia. The ricefield eel (as

also the swamp eel *M. cuchia*) is raised in cemented tanks. The advantages of raising this species are:

- it can be raised in small cemented tanks (there could be other innovations, but this paper deals with cemented tanks as an example);
- it can breed in captivity without using any chemical stimuli;
- it is an air-breathing species and can survive in oxygen-depleted conditions, and is, therefore, very useful in areas where water is scarce; and
- its natural foods are fish, snails, aquatic insects, invertebrates, worms, etc.

Methods

Tank preparation and stocking

1. Construct twin tanks 1 m x 2 m x 1 m in size with a total surface area of 4 sq m. The tank should be leak-proof with an outlet at the bottom.

2. Layer half of the tank lengthwise.

- The first (bottom) should be mud (preferably from ricefields or ponds) and is 10 cm thick.
- The second is composed of straw, previously cured for about a week, and 10 cm thick.
- The third consists of finely-chopped banana trunks, which are cut a week prior to introduction and must be 10 cm thick.
- The fourth is cow manure, also 10 cm thick.
- The fifth and top layer is mud placed on a slope with one end higher than the other.

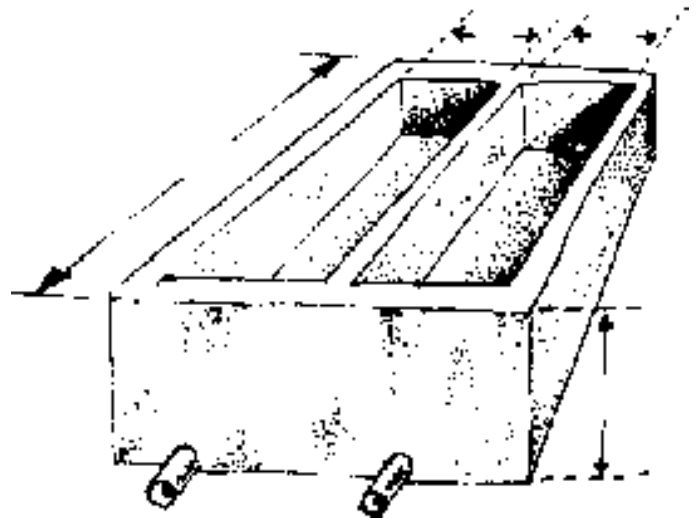

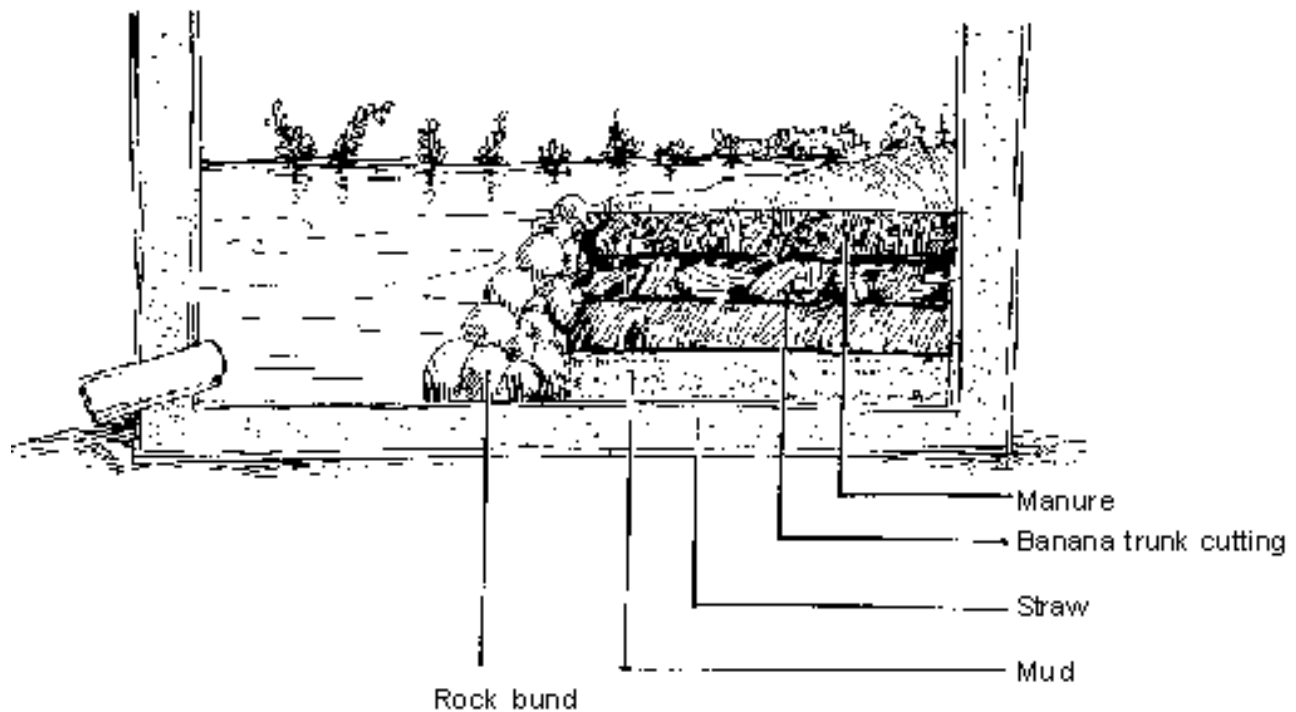

3. Ground or spring water could be used. Water from domestic faucets can also be used provided the chlorine content is not very high or can be lowered by some mechanism (spraying or holding the water in storage tanks).

4. Introduce water into the tank, 15 cm above the top layer, and allow the materials to decompose for about a week or until foam appears.

5. Drain the water and introduce fresh water again. Repeat this process every week for 20-25 days until no more froth appears.

6. Introduce *tilapia* or carp fingerlings to check if the tank is ready for culturing eels. Allow the fingerlings to stay in the tank for three days. If they do not die, that means the tank is ready for the introduction of eels. The tank, when ready, will have the same quality as a ricefield.

7. Before the introduction of eels, plant aquatic plants such as water hyacinth (*Eichhornia crassipes*) on the top soil. The plants will shelter the eels from direct sunlight and also act as a hiding place.

8. For the tank size mentioned, introduce 195 to 200 eels with a ratio of 140 females and 60 males.

9. The fecundity (egg-laying capacity) of *Monopterus* eels is low (ranging from 100-700 eggs per spawning), and, therefore, involves a very high degree of parental care.

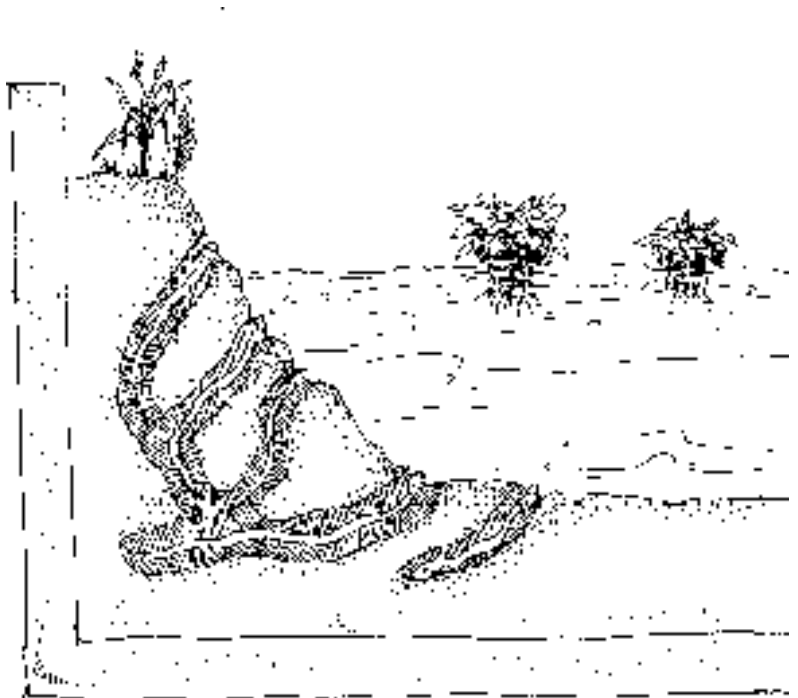

10. The fingerlings can either be obtained from someone who is raising them or from adult eels raised in your tanks.

Remember!

Monopterus albus is a protogynous (female first) species. In several species, a fish is a female as it grows and attains sexual maturity. As it grows further, however, it transforms into a male. The ones that are below 30 cm are females and those above 40 cm are males. Those whose lengths are in-between turn cannibal.



The breeding season varies from place to place although it is usually observed to take place with the onset of the rainy season.

Fingerlings, which cling to water hyacinth roots, should be segregated. Take out the weed and tap it over a net. The fingerlings will fall down. Repeat for a few days until there are no more fingerlings in the tank. Maintain in a separate tank or aquarium until they are pencil size. Then, transfer to new tanks.

Female

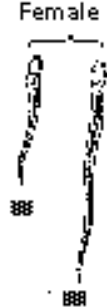

Male



Note

M. albus eels turn cannibal during the change from male to female because of hormonal changes.

Feeding management

1. Maintain proper feeding levels (3 - 6% of body weight/day) throughout the culture period. Feed eels with fish fingerlings, earthworms, snails, aquatic insects, silkworm pupae, slaughterhouse wastes (cow/carabao/chicken liver, intestine, chicken skin, etc.)

Tip

Silk-worm pupae, if available locally, are excellent foods for the eel. Live earthworms can be given directly to the fish or ground into a paste along with other fish and/or snails.

2. Use only mud from the pond or from a well-seasoned tank for nursery pond until

the hatchlings develop into fingerlings. Fingerlings can also be raised in aquarium with mud from the pond bottom.

3. Add flour or vitamin pre-mixed into the eels' natural food with the consistency of stiff paste (so the food does not dissolve in water and spoil the water quality).
4. Give food ingredients separately or in combination of two or more. A natural food, such as fingerlings of cheaper fish, is the most preferable.
5. At fingerling stage, feed eels with a lot of aquatic insects, which can be produced naturally in stagnant water bodies.
6. Collect golden apple snails from the rice fields to reduce the rice-eating snail population and feed them to the eels.
7. Consider the following factors in feeding:
 - size (length) of the fish;
 - biomass (total weight); and
 - climatic conditions, such as atmospheric temperature.

An ideal temperature for eel to feed properly would be between 20-35°C.

Harvesting and transporting

1. Harvest according to the needs of the market and the growth of eels.
2. Harvest partially or completely. If you have more than one tank, harvest completely so that the next lot is ready in the new tank before harvesting.
3. Harvest during feeding time when a net can be placed under the feed.
4. Make sure not to injure the eels as it may, besides causing death, lower the market price.
5. Starve the eels in holding tanks before transporting live to the market.
6. Clean the tanks properly after harvest and sun-dry for a few days before stocking with new eels.

Ecological implications

Some farmers who have introduced *Monopterus* eels in their rice fields have noticed a marked reduction in snails as these are natural feed for the fish. However, some

farmers have come across the problem of dike-boring by eels, which make it difficult to retain water in the rice fields. The ecological implications of these species in the wild are being studied. Introducing the eel into the rice field will involve additional management efforts for the dikes.

Eels, once introduced into the rice field, can serve as predator of golden apple snails, which have become a pest in some Asian countries, particularly the Philippines and Vietnam.

The introduction of eels helps enhance the biodiversity value of rice fields and neighboring swamps.

References

Department of Environment and Natural Resources. 1997. Sustainable Livelihood Options for the Philippines: Upland Ecosystem.

Fishery Department for the Future. 1974. FAD; Department of Fisheries – United Nations.

Nasar, S.S.T. 1997. Backyard Eel Culture. International Institute of Rural Reconstruction, Silang, Cavite, Philippines.

Nasar, S.S.T. 1989. Biology of the Mud-eel, *Monopterus albus*, unpublished Ph.D. dissertation.

Small-Scale *Macrobrachium* Culture in Bangladesh

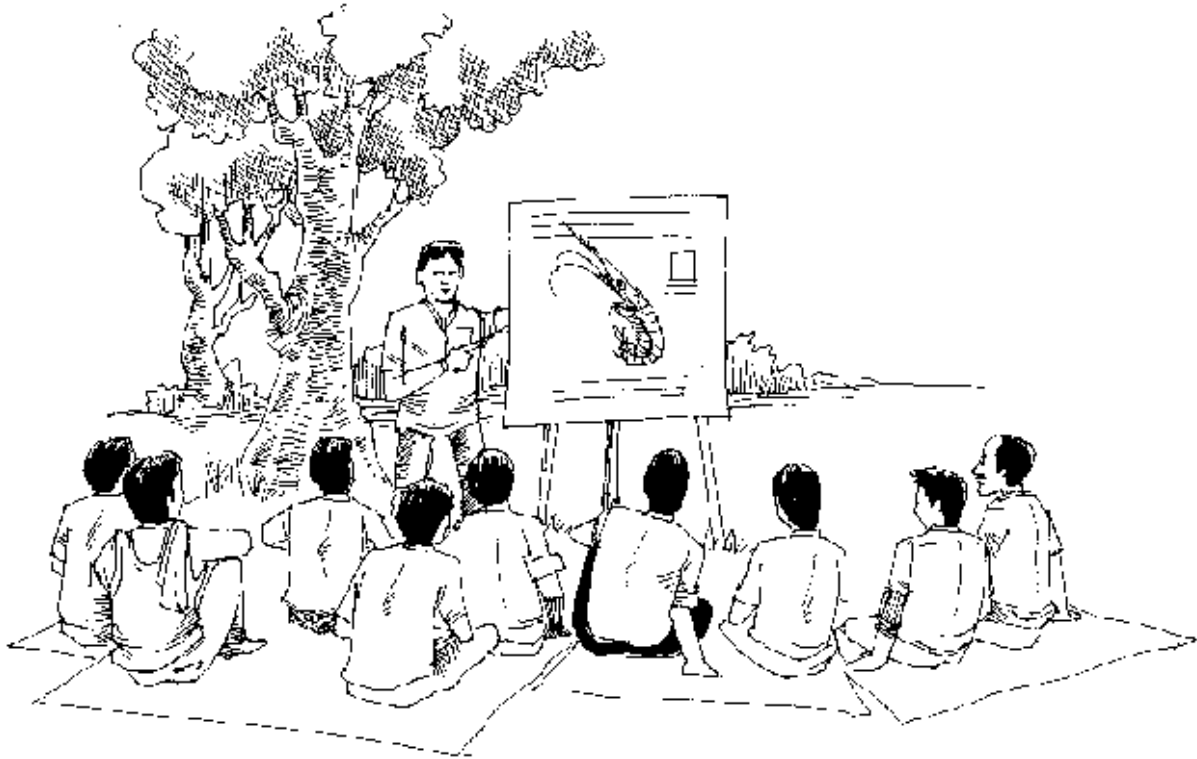

Farmers in the Southwestern (coastal zone) part of Bangladesh have developed a new method of using rice fields for cultivating both prawns and rice. The low-lying areas frequently get flooded during the monsoon season and the new high yielding varieties of rice are not appropriate. Generally, farmers are able to cultivate rice only during the boro season (dry season). During the monsoon these areas remain fallow.

The cultivation of prawn and rice in modified rice fields is called "Golda Gher". Golda is the Bangla word for the giant freshwater prawn (*Macrobrachium rosenbergii*) while Gher refers to elevation of bundhs. This type of culture is seasonal.

Gher construction

- Use paddy fields located in the low-lying areas for better water holding capacity.
- Dig canals all around the paddy field to a depth of 1.5-2 m and use the excavated soil for making dikes on all four sides of the field.

- Leave the middle portion of the field unexcavated. The shapes of the canal vary depending on the location of land and interest of the farmers. Canals should cover 30-40% of the area. The rest of the area should be left as is.
- Use the canal for stocking prawns.
- In the dry season, use the un-excavated portion for growing rice. During the monsoon season the entire Gher will look like a pond, while in the dry season, a clear distinction between rice fields and the canals can be seen. The average size of the gher is about 0.2 ha.



Gher preparation

I Fill most of the Ghers with rainwater.

I Most farmers apply lime as a prophylactic treatment for ponds and to amend the soil pH at the rate of about 500 kg /ha. When Gher is dry lime it is applied directly but when Gher is wet

lime it is applied to the water at the same rate of 500 kg/ha. Lime is applied all over the Gher.

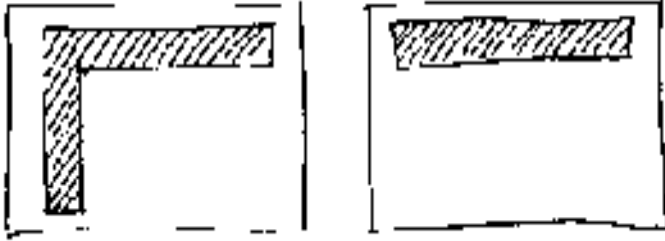

I Fertilize Gher water with both cow dung at the rate of 1,250 kg/ha and with inorganic fertilizers, like urea and triple super phosphate, at the rates of 25 kg/ha and 37.5 kg/ha, respectively.

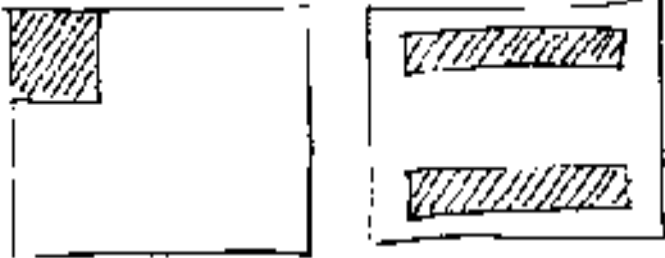

I When the water turns green, stock the Gher with prawn and fish seed. There is generally no exchange of water as it is a stagnant water culture system.

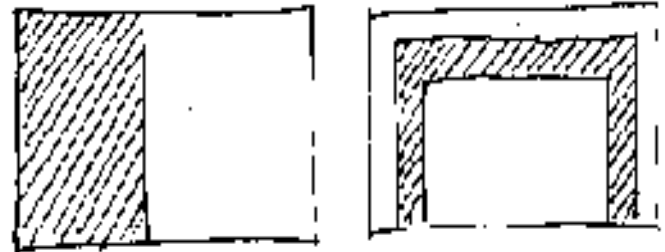

I Maintain water's green color through regular fertilization with both organic and inorganic fertilizers.

Stocking

Most of the prawn seed required for stocking is obtained through natural collection in the coastal area. There is a good network of people actively

involved in organizing seed supplies to farmers. The post larvae procured from the wild by fishers reach the farmers through a number of intermediaries. Prawn hatcheries are developing slowly, with the decline in seed availability from the wild. The prawn post larvae are stocked at the rate of 20,000-30,000/ha, while juveniles are stocked at the rate of 10,000-15,000/ha. Along with prawn seed, farmers also stock various species of Chinese and Indian carps, mainly for regulating water quality. Stocking is usually completed between May and August. Early stocking is preferred, but due to difficulties in obtaining seed at the right time, stocking is sometimes delayed by 3-4 months.

Feeding

Farmers maintain green water by periodic fertilization of the pond but they place a heavy emphasis on supplemental feeding of the prawns. In the early years, feeding prawns with snail meat was common but now it is being replaced by homemade feed using a variety of easily available ingredients. Women usually produce these feeds and some have undertaken feed production as an income generating activity.

Common ingredients used in feed preparation are fishmeal, ground rice, rice bran, wheat bran, molasses, mustard oil cake, etc. Farmers have developed a number of indigenous feed-making devices. Dried feed is given at the rate of 3-5% of the total biomass of prawn/fish.



Farmers adopt broadcast as well as tray feeding. Feeding is generally done in the evening to facilitate nocturnal feeding habits. Adjusting the feeding rate can easily be done by farmers as they resort to continuous harvests at periodic intervals. Snail meat is still being used as feed by the farmers because of the belief that the growth of prawns can be improved by giving them raw meat. This belief is more common among wealthier farmers.

Harvest

Prawns are harvested several times a year and sold to local buyers. There is a good network of intermediaries involved in the regular collection of small harvests of prawns from farmers and bringing them to the processing centers. Prawns are harvested at least three to four times during the season and, depending on Gher management, harvests may reach 150-350 kg/ha.

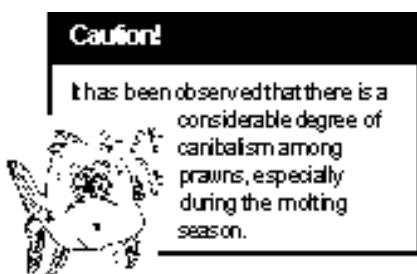

The sizes of the harvested prawns vary. In general, the average size preferred by processing factories is 60-80 g. Harvesting is completed by November-December and the small prawns are left behind and allowed to grow for another few months up to March-June. Small farmers sell the bigger prawns in March-April and buy the required

seed for stocking in May and June.



Use of dikes for vegetable cultivation

Farmers utilize the dikes for the cultivation of different vegetables, with the silt removed from the canals serving as good fertilizer. Income from vegetable growing could account for 30-40% of total income.

Cultivation of rice in the elevated area (Gher)

When the water level can be easily maintained in the Gher, cultivation of two crops of paddy is undertaken: during the monsoon and dry seasons. Farmers can grow nearly enough rice to meet all the family's needs.

Profitability of the system

The profitability of the system largely depends on the amount spent on seed and feed, efficient utilization of the dikes for vegetable cultivation and the size of the central un-excavated area for rice cultivation. In some cases, farmers have focused too heavily on prawns thereby increasing their risks. Alternative options are suggested to reduce these risks and to increase profitability.

Using the "Golda Gher" method, farmers have been able to derive cost benefit ratios of up to 1:4. Such a high profitability has encouraged many small farmers to adopt the system. However, these small farmers get trapped in debt, especially if they do not get any technical advice. Emphasis is placed on understanding the ecosystem and developing a scheme that is appropriate to his/her economy and farming system.

Constraints encountered

- **Exploitation by money lenders.** Many institutions lend money to farmers, but very few organizations advise farmers on the wise use of credit.
- **Unplanned expansion of ghers.** Due to the profitability of the system, there is

unplanned expansion, which often blocks waterways and results in water logging.

- | **Heavy usage of snail meat.** Rich farmers continue to exploit snails for prawn feeding and this may strain the ecosystem.
- | **Prawn seed.** Almost all the seed required is currently collected from coastal areas. In the process of collection, seed of many other species are damaged. Already there are signs of a gradual decline in seed availability from the wild.
- | **Focus on prawns.** Due to the high price of prawns, farmers tend to focus too much on prawns and invest too much on seed and feed, thereby increasing risks of losses and failures.

Strategies to address these constraints

- Farmers acquiring credit facilities are trained on financial management.
- Credit systems that meet the needs of farmers and help them establish self-help groups are promoted.
- Mass education using drama and posters to address unplanned expansion of ghers and to enhance the management of existing ones. An eco-village concept, which focuses on eliminating environmentally unfriendly practices, is pursued.
- Improvement of existing cultivation practices with focus on developing feeds and improving feeding strategies. Farmers have used a wide variety of strategies appropriate to their farm.
- Farmers are encouraged to develop systems that reduce risk and increase profitability through various options that are easily available. Efficient use of dikes, adequate emphasis on growing prawns with fish and growing more than one crop on paddy are some of the systems that have shown promise.

Conclusion

Freshwater prawn cultivation is a potential tool in the alleviation of poverty in Bangladesh. A good network and market structure are in place. Farmers' produce is also collected, serving as a major stimulus in the development and adoption of this new system. There are opportunities to explore the adaptation of this farmer innovation in other areas, both within and outside Bangladesh.

Culture of Chinese Mitten-Handed Crabs

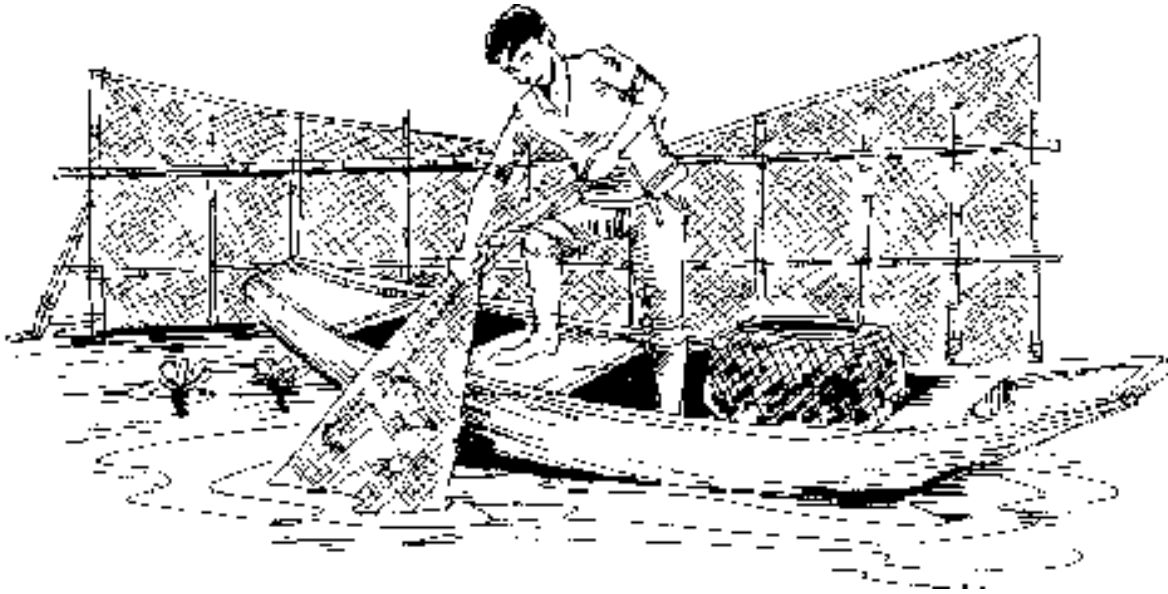

Chinese mitten-handed crab (*Eriocheir sinensis*) is considered a delicacy in China and in some overseas Chinese communities. It is not a traditional species for farming, but its culture and culture-based resource enhancement in shallow freshwater lakes have become popular because of its high market value. The mitten-handed crab enjoys good domestic and foreign markets especially in Southeast Asia. Large crabs fetch a higher price than small ones.

Although the production cost for crab culture is higher than that for traditional fish farming and crab prices have recently declined, in general, crab culture still attracts farmers.

Though culture with seeds collected from the wild can be traced to three decades back, the success of artificial breeding in the 1980's boosted the rapid development of crab farming.

Retail price of female mitten-handed crabs		
Year	Small (<100 gm)	Large (>150 gm)
1996	140-160 Yuan/kg	260-360 Yuan/kg
1997	70-80 Yuan/kg	280-400 Yuan/kg

(8.28 Yuan = US\$1.0)

Biological features

- The natural distribution ranges from sub-tropical to temperate zone in China;
- In the wild, Chinese mitten-handed crabs grow in freshwater and migrate to the sea in autumn to spawn when they reach sexual maturity. This normally takes about two years in central and eastern China.
- From juvenile to marketable size (mature), the crab molts many times. Crabs grown in the same environment do not molt at the same time. Newly molted, soft-shelled crabs are vulnerable to other crabs especially when there is not enough food.
- The mitten-handed crab is omnivorous. It exhibits a preference for food of animal origin over plants. It is nocturnal, thus it is more active at night in terms of feeding.
- Natural habitats include freshwater lakes, swamps, irrigation canals and slow moving rivers, etc. Chinese mitten-handed crabs prefer clean shallow water with loamy or clay bottom conditions. In addition, water bodies with submerged aquatic plants are preferred as shelter and because of abundant food sources.

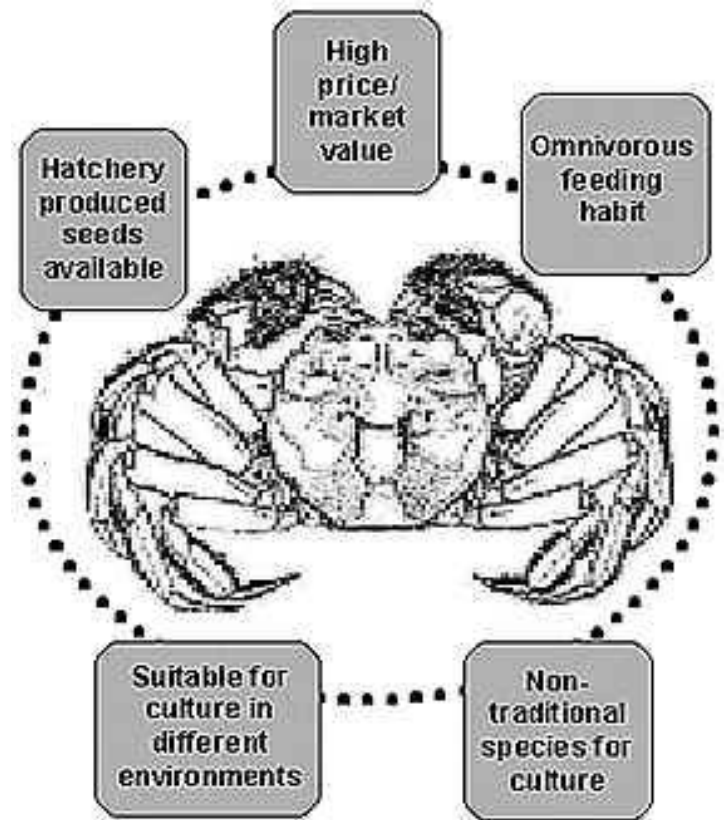

Stock resources and seeds

The Chinese mitten-handed crab has three different populations (called sub-species by some scholars), which are found in the south, the central and eastern regions, and northern China. The variety naturally occurring in the Yangtze River is considered the best variety for culture because of its fast growth performance and better market value.

Both hatchery-produced and naturally collected larvae are available. The availability of natural seeds, particularly in Yangtze River, is declining under excessive pressure of fishing for larvae. This has given rise to the crab hatchery industry. A complete scientific understanding of its reproductive biology is yet to be established through further in-depth research to ensure more efficient and cost-effective production of quality seed. Crab seeds of different origins are sold for farming purposes or released into open waters for stock enhancement, leading to the mixing of stocks in the wild. There is increasing evidence of poor growth and disease

resistance of the species. Hence, there is an urgent need to regulate crab seed production and marketing through appropriate mechanisms such as certification, accreditation and licensing, similar to what has been established in the field of agriculture.

Hatcheries and nursery farms grow crab larvae to "coin-size" (60-150 pcs/kg) to be sold to other farmers for grow-out culture. Some farmers purchase the larvae directly for nursing in the first year and then grow them to marketable size the following year. This crab culture system requires special skills because there is a high risk of failure.

Culture methods

The Chinese mitten-handed crabs have been cultured in pens in shallow freshwater lakes, earthen ponds (with fence to prevent escape), fenced renovated paddy fields and covered net cages. The best results were obtained from pen culture in shallow lakes. Growth and quality (size, appearance and fatness) in pen culture are impressive, probably because pens provide crabs with an environment that is close to their natural habitat.

Net pen culture of crabs

Culture of mitten-handed crabs in net pens is extensively practiced. Supplementary feeding is needed in addition to the natural food available in the pen. The normal yield is 300-450 kg/ha, but it could go as high as 900-1200 kg/ha with improved management skills and better levels of inputs. However, the greater yield may not always result in bigger crab size at harvest.

1. Site selection

- Preferably flat with hard bottom; avoid bottom with thick silt or mud.
- Good water quality; pH 7.5-8.5; dissolved oxygen not less than 5 mg/l; free from pollution; mild flow of water (less than 5 cm/sec).
- Avoid navigation waterway/route.
- Water depth between 0.8-1.5 m, without much water level fluctuation.
- Abundant sub-merged aquatic plants

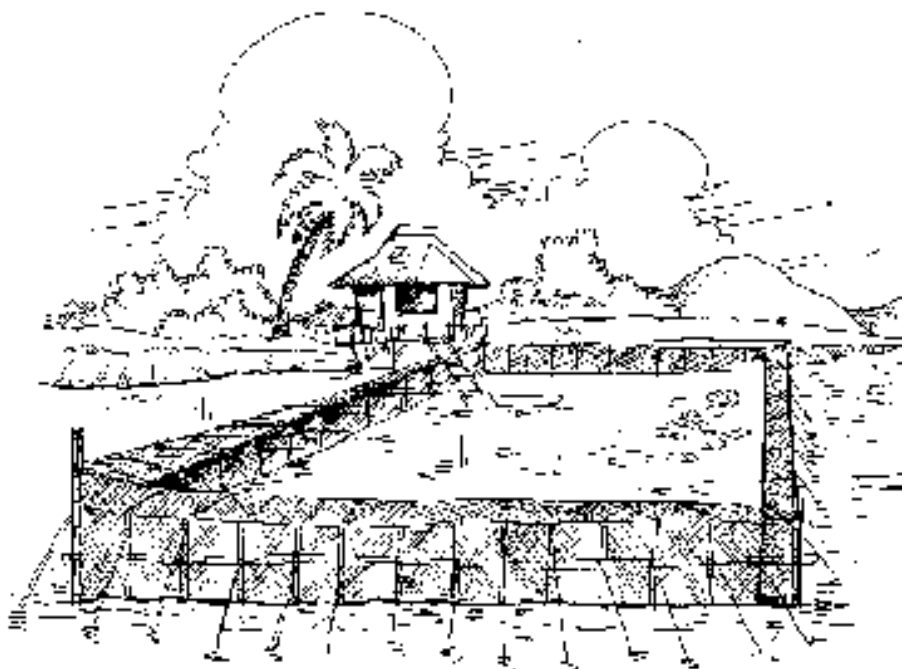

(desirable species include: *Hydrilla verticillata*, *Vallisneria spiralis*, *Potamogeton crispus*, etc.), snails, clams and aquatic insects, etc.

2. Net pen design and installation

- Size of net pen suitable for family operations ranges from 0.4 to 5.0 ha, depending on the farmer's available capital. The pen could be rectangular, oval or round. The shape does not matter very much as long maximum water exchange through the pen is ensured.

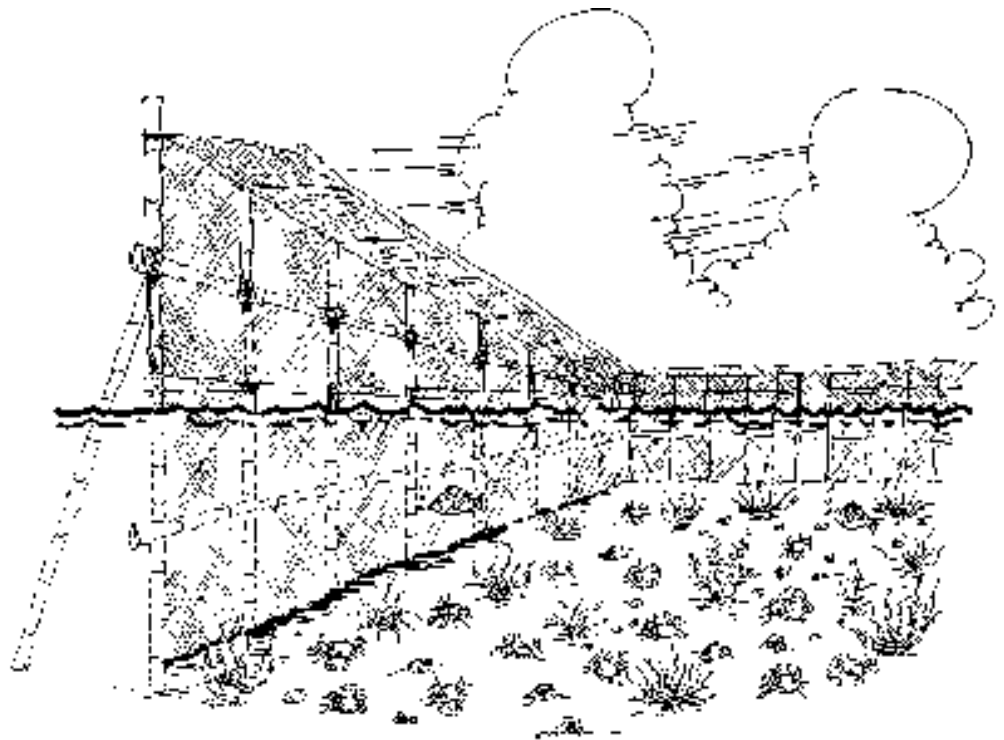

- Bamboo stakes or small logs and ready-made polyethylene netting can be used for the construction of the enclosure. The mesh size is 2-3 cm. Sometimes, a second outer layer of pen, made of bamboo screen or net, is built to prevent the crabs from escaping. The distance between inner and outer layers is 2-4 m.
- Bottoms of the net are sewed together to hold gravels or stones and are buried 20-30 cm deep in the bottom soil. Top of the net should be 0.8 – 1.0 m above the water, with 0.5 – 0.7 m of additional net extending horizontally from the top inwards to prevent crabs from escaping. The cross section of the net looks like an upside down "L".
- If the water and bottom conditions are favorable, the net pen for fish culture can be modified for crab culture.

3. Pen preparation and stocking

- Before stocking, carnivorous fish, such as snakehead, mandarin fish and catfish, should be removed from the pen because they could prey on the farmed crabs.
- Transplant aquatic plants into the pen, if there are not enough. It is recommended to cover at least 20% of the pen bottom area with submerged

vegetation of desirable species.

- Fish that graze on aquatic plants like grass carp and bottom dwellers like common carp must be removed from the pen. Grass carp and common carp could disturb the growth of crabs and compete for food. Water rats in nearby area should be killed with appropriate methods to avoid damage to the net pen and to prevent them from preying on the crabs.
- Quicklime dissolved in water should be applied by broadcasting it in the pen to disinfect the culture area.
- Crab seeds with 6-15 g/pc or 65–150 pc/kg size are desirable. The recommended stocking density is 60-150 kg/ha. The pen could be stocked starting from February to April as usually practiced in China.
- Some filter feeder fish like the silver and bighead carp could be stocked in the pen as bring-along species for culture. They help clean the water in the pen.

4. Routine management

- Supplementary feeds include aquatic plants collected from outside, vegetables, squash, sweet potatoes, boiled corn and wheat, etc.
- Animal feeds include crushed snails and clams, trash fish, slaughterhouse waste, and silkworm pupae, etc.
- Feeds are added to the pen twice a day (early morning and in the evening). The feeding rate is 3-6% of the body weight per day. About 30-40% of the daily ration is given in the morning and 60-70% in the evening. Animal protein feeds should account for 50-60% of total feed.
- Daily removal of leftover feeds (particularly in the morning) is important to keep the pen area clean.
- Daily check of the enclosure is recommended to ensure that damage to the net is repaired immediately.
- Broadcast 8-10 kg/ha of quicklime every three weeks.
- For large pens, if aquatic plants grow too much, some plants should be cut in a row (1 m wide) parallel to the water current to allow faster water exchange in the pen.

5. Disease prevention and control

- Preventive measures are more effective. A clean culture environment helps reduce the risk of diseases.
- Diseases constitute a major threat to the success of culture. In 1998, the outbreak of "shivering disease" (common term, not well defined so far) caused US\$120 M worth of losses to crab farmers nationwide.
- Basic research is lagging behind but chemicals and drugs have been developed based on preliminary research work and been commercially produced.
- Certain chemicals such as malachite green, copper sulfate, zinc sulfate, etc., commonly used for fish disease control or treatment are not suitable for crabs (different toxicology).

6. Harvest and conditioning

- The crabs are harvested when they reach maturity and are ready to migrate to the sea in mid-September to mid-October, when temperature drops to 12°C. Crab traps and gillnet are used for harvest.
- Crabs are kept in holding tanks or cage before marketing. Feeding of the crabs in holding tanks should continue for fattening purposes. Holding of the crab also allows the farmers to wait for a better price before selling the product.
- Crabs must be kept alive until it reaches the consumer's kitchen. Dead crabs have no market value at all.

Conclusion

Crab farming is a relatively simple aquaculture practice, suitable for both large and small scale operations. At present, the seed of crabs is still expensive and quality of seeds not consistent through years. Further development in hatchery technology and nursing techniques will help to reduce the production cost by providing cheaper seeds in the future.

Prepared by:

Zhou Xiaowei

Aquaculture and Sewage Water Treatment

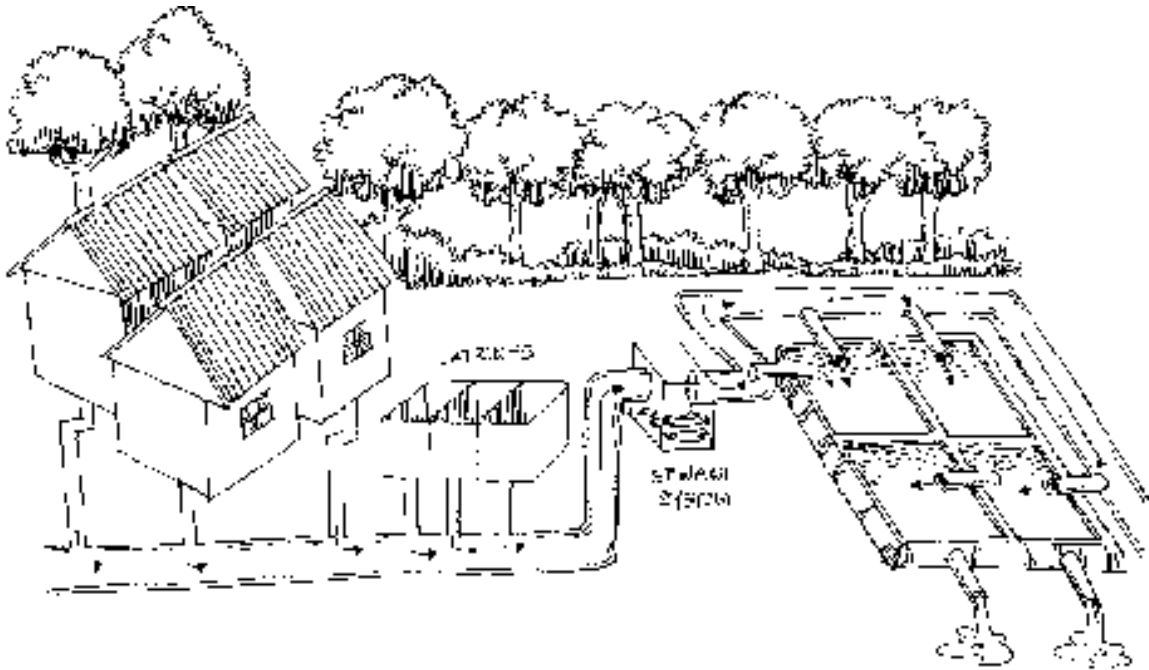

Growing population and the lack of a corresponding infrastructure for waste water treatment are growing concerns. In every country, the generation of domestic sewage escalates, often beyond the capabilities of conventional sewage treatment plants, which include oxidation/waste stabilization pond, activated sludge, trickling filter, aerated lagoons, upflow anaerobic sludge blanket process, etc. At the same time, it is increasingly being recognized that sewage is not just a pollutant, but rather a nutrient resource. Traditional practices of recycling sewage through agriculture, horticulture and aquaculture have been tried in several countries. This article discusses the role of aquaculture-related approaches for processing sewage water.

Sewage is a dark colored, foul-smelling fluid containing organic and inorganic solids in dissolved and suspended forms. It contains 90 to 99% water, 10-70 mg/l nitrogen, 7-20 mg/l phosphorus, 12-30 mg/l potassium.

Characteristics of sewage	Weak mg/l	Medium mg/l	Strong mg/l
Total solids	350	720	1200
Dissolved state	250	500	850
Suspended form	100	220	350
Settleable condition	5	10	20
Biochemical oxygen demand (BOD) at 20°C for 5 days	100	200	400

Sewage-fed culture



Several variations from overhung latrines over the ponds to the application of primary treated sewage into fish ponds exist. The sewage-fed fish culture in Munich, Germany and sewage-fed *bheries* of West Bengal, an Eastern State of India, have been extensively studied. The practices in over 5,700 ha area in Bengal produce over 7,000 tons of fish annually.

Normal management practices

- Fry stocking: 30-50 mm
- Fish density: 40,000 – 50,000/ha
- Sewage application: weekly or bimonthly intervals
- Field indices for pond's sewage intake: algal blooms, fish surfacing, dark color of water
- Production rate: 3-7 tons/ha/year

Carp polyculture is practiced in most of these waters

- Silver carp (*Hypophthalmichthys molitrix*)
- Common carp (*Cyprinus carpio* var. *communis*)
- Indian major carps – Catla (*Catla catla*), Rohu (*Labeo rohita*) and Mrigal (*Cirrhinus mrigala*)

Other medium and minor carps

- Bata (*Labeo bata*)
- Reba (*Cirrhinus reba*)
- Mola (*Amblypharyngodon mola*) are often used as components of fish culture in these waters

Problems related to sewage-fed culture systems

- Accumulation of silt and high organic matter at pond bottom
- Incidence of parasites and fish diseases
- Possibilities of pathogens being transferred to humans

Solutions

- Regulate sewage intake into the ponds
- Provide freshwater for dilution
- Use of prophylactics
- Depuration of fish in freshwater before marketing

Several modifications in the system are also being suggested to achieve greater efficiency and sustainability.

Sewage treatment through aquaculture

Resource recovery from wastewater is important not only for realizing the nutrients as food, but also in ensuring that they do not contribute to the eutrophication of natural waters that are the usual receptors.

Biological treatment of sewage using algal-bacterial associations, macrophytes and fish employ both autotrophic and heterotrophic food chains, rendering the effluent nutrient-deficient and less harmful to the environment into which it is discharged.

Ponds serve as facultative receptacles for sewage treatment, and also provide oxygen input from the photosynthesizing algae and macrophytes. Ponding reduces the bacterial loads by two to three log units and bacteriophage loads by three to four log units even at the loading rates of 100 kg COD (chemical oxygen demand)/ha/day.

Principles of wastewater treatment models

- Dilution
- Oxidation
- Reduction of suspended solids along with nutrient recovery in terms of biomass

Aquaculture-based sewage treatment plant (ASTP)

An aquaculture-based sewage treatment plant designed in India has incorporated cultivation of duckweeds prior to application of fish ponds and post-fish culture depuration, with the objectives of refinement of sewage-fed fish culture and sewage treatment through aquaculture practices.

The ASTP consists of a set of duckweed ponds, fish ponds and depuration ponds, located at a place 250 m away from the residential area and borewells. Gravitational flow of sewage wherever feasible for sewage intake into the treatment

complex will be advantageous.

Design and construction of a model to treat 1 mld sewage

A model for treating one million liters per day (mld) of sewage, from a population of about 20,000 is described below:

Source: A receiving chamber for sewage feeds the effluent to the ASTP.

Duckweed culture complex: It comprises 18 ponds with brick lining (25 m x 8 m x 1 m), with three series of six ponds in a row. The sewage is retained here for a period of two days, with free passage between the series.

Fish ponds: Two fish ponds (50 m x 20 m x 2 m) receive the treated sewage from the duckweed ponds and retain it for three days.

Depuration ponds: Two depuration ponds (40 m x 20 m x 2 m) with freshwater, also used as marketing ponds, provide for depuration of fish for a week before marketing. As the fish harvest is occasional, these ponds are also used for the culture of grass carp, fed with duckweeds from the system.

Outlet: Sewage outlet drains are provided from the fish and depuration ponds for drainage into natural waters.

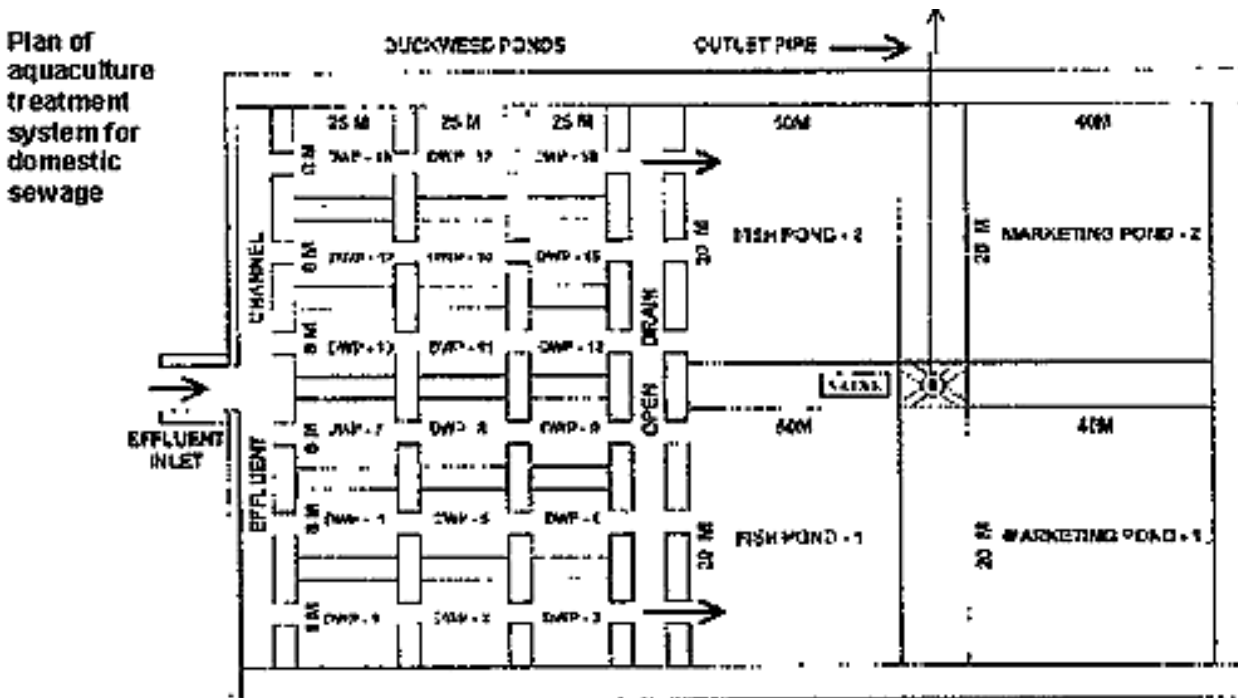

Duckweeds and fern used depending on availability



Spirodela



Wolffia



Lemna



Azolla

Duckweed culture

Duckweeds serve as nutrient pumps, reducing eutrophication effects and providing oxygen through the photosynthesis activity.

The ponds are inoculated with duckweeds to cover roughly one-third of the surface area (400 g/sq m). The approximate growth rates of individual weeds in the sewage-fed culture system are *Spirodela* 350 g/sq m/day, *Wolffia* 280 g/sq m/day, *Lemna* 275 g/sq m/day and *Azolla* 160 g/sq m/day. The harvested weeds could be used to feed grass carp in the marketing ponds or composted for application in fish ponds and horticulture fields.

Fish culture

The ponds are stocked with Indian and Chinese carps at a density of 10 000 fingerlings/ha (Catla 40%, Rohu 40% and Silver carp 20%). Grass carp, *Ctenopharyngodon idella*, is stocked in the marketing pond and fed with duckweeds harvested from duckweed ponds. The fish stocks are checked at monthly intervals for their health

and growth through sample nettings. By monitoring of dissolved oxygen levels to maintain 3-5 mg/l, the sewage flow is regulated. Fish harvest is carried out 8-12 months after stocking, with mean individual sizes in the range of 600–800 g. About 600-700 kg of fish are harvested from the two fish ponds, working out to a production level of 3-3.5 tons/ha/year and about 400 kg of fish are harvested from the marketing ponds, representing considerable economic returns from the sewage.

Candidate fish species for sewage-fed fish culture

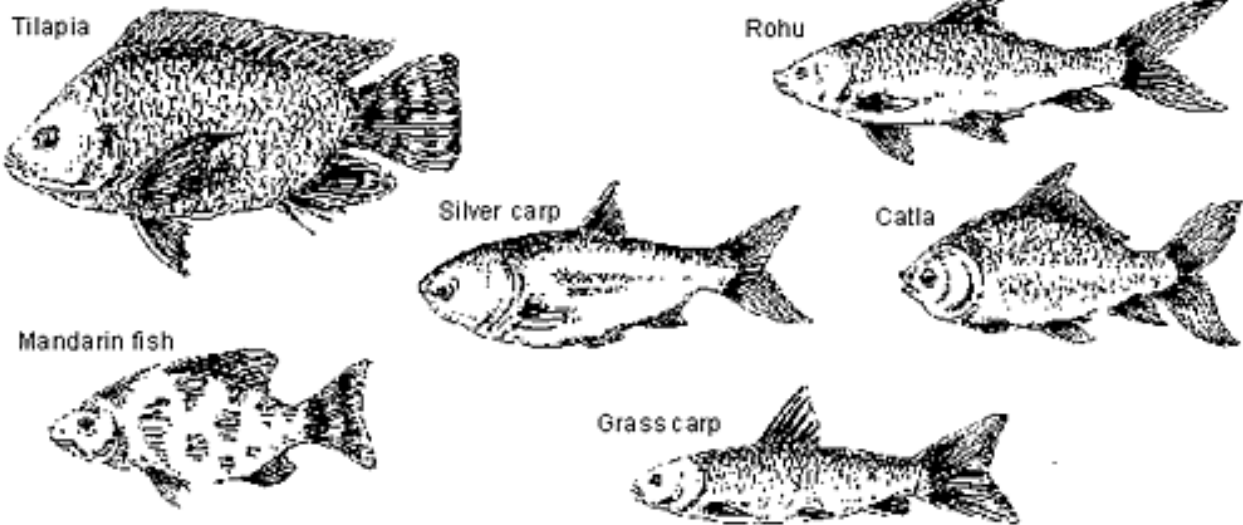

Depending on the area of operation, different fish species could be used. Tilapia (*Oreochromis* spp.) and Mandarin fish (*Siniperca chautsi*) are some of the species that are cultured in sewage-fed waters in China and other countries.

The ASTP provides for retention of sewage for two days in duckweed ponds and three days in fish ponds. This achieves the desired reduction in nutrient concentrations, BOD, COD and the bacterial populations to meet the standards for discharge into natural waters. The fish produced from the system enables recovery of about 40% of the working costs.

This model has been used in several Indian villages for community sanitation and aquaculture, with modifications. Typically, a third of the pond of the size of 0.2–0.4 ha at the inlet end serves as the receptor of sewage from solid wastes from community latrines. This portion is stocked with duckweeds that multiply in the presence of organic matter and effluents that then pass into the adjacent portion of the pond stocked with fish. With a continuous flow, the organic loading is regulated in different seasons.

Total area required

Duckweed culture complex

Individual pond :	25 m x 8 m x 1 m
Total no. of ponds :	18
Area :	3600 sq m

Fish ponds

Individual pond :	50 m x 20 m x 2 m
Total no. of ponds :	2
Area :	2000 sq m

Depuration/Marketing ponds

Individual pond :	40 m x 20 m x 2 m
Total no. of ponds :	2
Area :	1600 sq m
Total water area :	7200 sq m

Wastewater reuse in Hanoi, Vietnam

- Fish culture with silver carp, rohu and tilapia fed with wastewaters, in rural areas around Hanoi, with annual yields of 5-8 tons/ha/yr.
- Rice and fish in shallow ponds: 4-5 tons rice and 3 tons fish/ha/yr.
- Vegetable farming incorporated.
- 4,500 tons of fish from wastewater fed system, 40-50% of the total fish supply to Hanoi.
- IUCN, WHO, The World Bank and International Center for Waste Disposal recognize wastewater reuse in aquaculture as an important form of waste disposal.

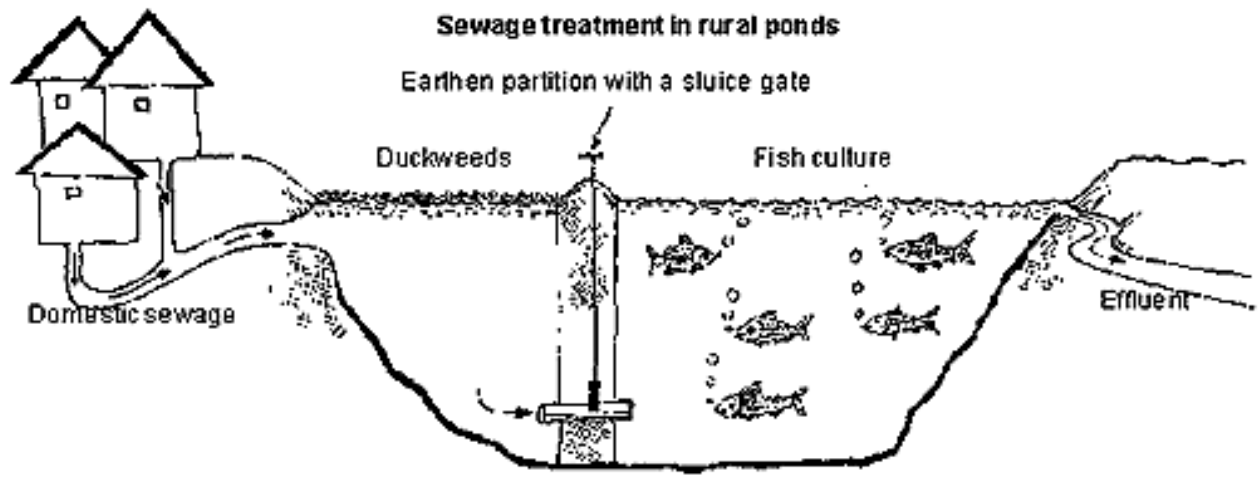

Prepared by:
S. Ayyapan

Water Quality Management for Freshwater Fish Culture

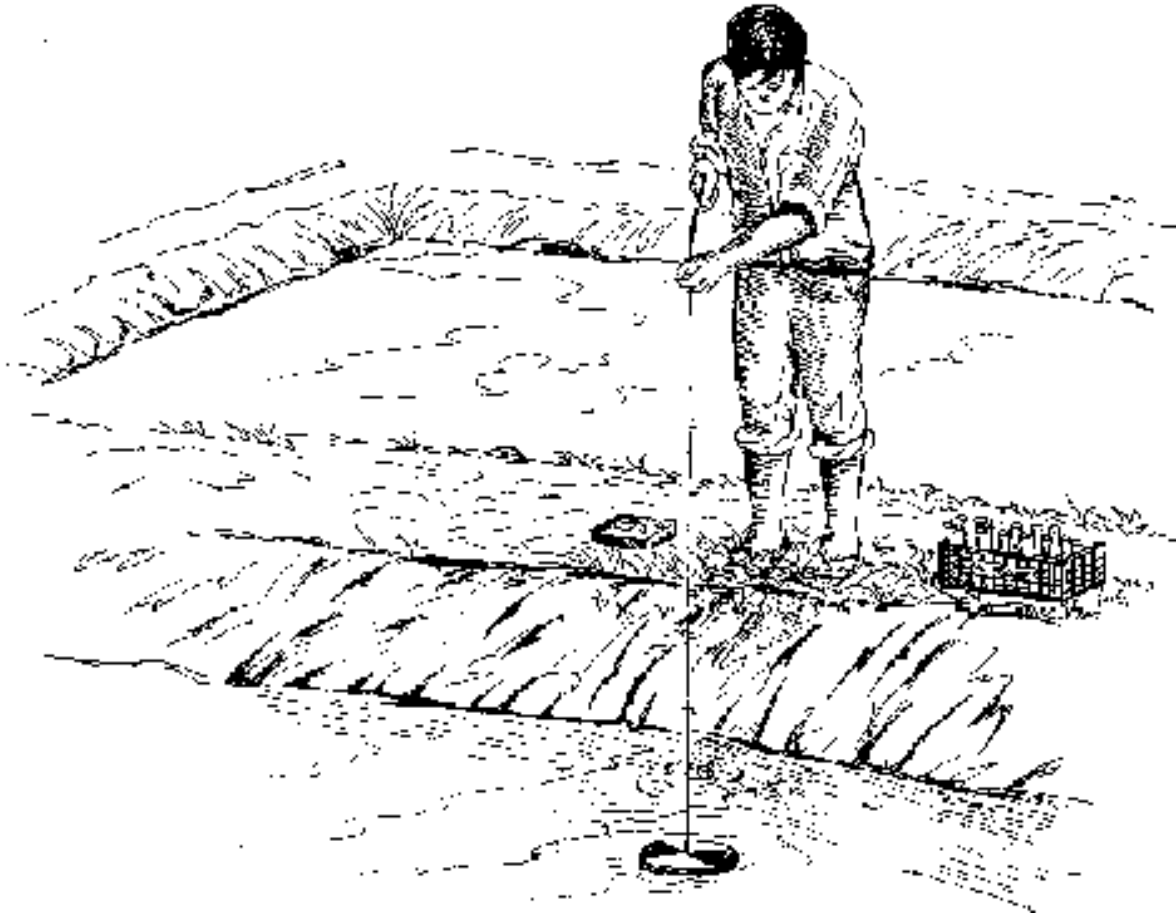

The aquatic environment governs fish life, hence, water quality should be suitable for fish culture. When environmental conditions do not conform to the optimal range for normal fish growth, then fish culture could be affected. The major concerns of fish culturist should be to deal with the aspects of water quality that may cause poor growth or death of fish. Water quality management aims to regulate environmental conditions so that they are within a desirable range for growth and survival of fish.

Examples of variables

- Temperature
- Turbidity
- pH
- Alkalinity
- Total hardness
- Calcium
- Dissolved oxygen
- Carbon dioxide
- Ammonia
- Hydrogen sulfide
- Total gas pressure



The aquatic environment is composed of many variables. Fish culturists must know the variables that are potential sources of stress for the fish. The variables may also explain the causes of fish culture problems.

Although, these parameters can be analyzed using standard laboratory procedures and apparatuses or water quality analysis kits, there are practical indications when these parameters become risky to the fish.

Water quality variables and their effects

on fish

Temperature

Fish are cold-blooded and dependent upon the water temperature in which they live. Every fish species has an ideal temperature range within which it grows quickly.

Common fishes and their optimum temperature ranges

Common name	Scientific name	Water temperature (°C)
Tilapia	Oreochromis mossambicus	25 - 35
Gourami	Osphronemus goramy	24 - 28
Tawes	Puntius javanicus	25 - 33
Common carp	Cyprinus carpio	20 - 25
Grass carp	Ctenopharyngodon idella	25 - 30
Eel	Anguilla japonica	20 - 30
Silver carp	Hypophthalmichthys molitrix	25 - 30
Rohu	Labeo rohita	25 - 30
Mrigal	Cirrhinus mrigal	25 - 30
Catla	Catla catla	25 - 30

Temperature does not act alone. If the fish show signs of distress because of hot weather, these are often caused by high temperature and low oxygen content.



Gourami



Common carp



Mud carp



Tawes



Grass carp

Dissolved oxygen (DO)

The concentration of DO in natural water is influenced by the relative rates of diffusion to and from the atmosphere, photosynthesis by aquatic plants and respiration by the entire aquatic biological community. Oxygen is the most common limiting factor to fish life.

Aquatic fish species breathe best when DO concentrations are near saturation. As DO concentrations decrease, fish are stressed and their immune function may be compromised. DO concentration of 5 mg/l or greater should be maintained for normal fish culture.

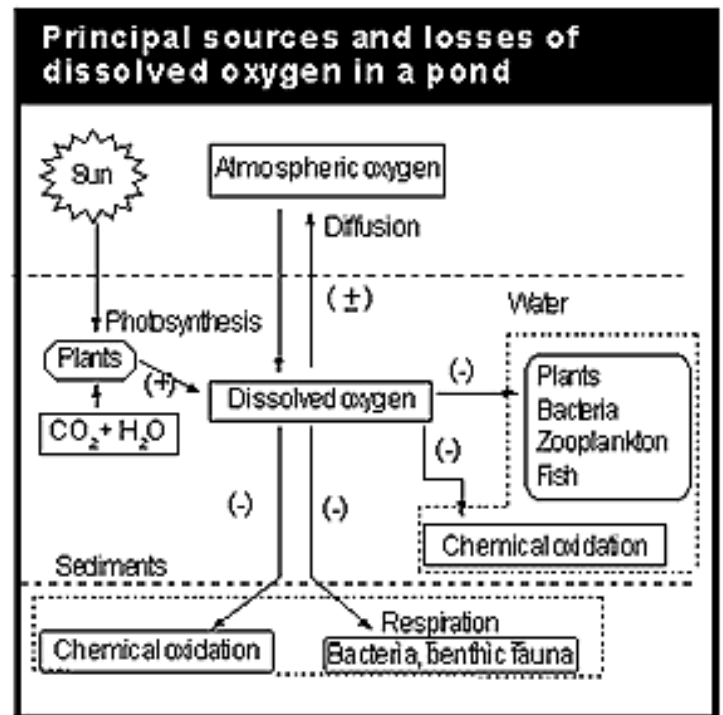

Common water quality problems and corresponding management techniques

Low-alkalinity water and acid sediments

Liming can often solve problems with acid-base relationships in fishponds. Waters with alkalinity of less than 25 mg/l often need liming. Application of liming materials is not a type of fertilization. Liming may be best viewed as a remedial procedure, necessary in some ponds to permit the normal responses of fish population to fertilization and other management procedures.

Finely grounded limestone (<0.25 mm) has a high neutralizing value, thus, is the first choice for fishponds. Quicklime or slaked lime used in large quantities cause the pH to increase damaging the fine tissues coating the gills, thus causing the death of fish.

Liming rates

Application rates for lime are based on the efficiency rating of the liming material and its neutralizing value. Lime requirement of bottom mud can also be based on pH and texture of mud.

Mud pH	Lime requirement (kg/ha of CaCO ₃)		
	Heavy loam or clay	Sandy loam	Sand
<4.0	14,320	7,160	4,475
4 - 4.5	10,740	5,370	4,475
4.6 - 5.0	8,950	4,475	3,580
5.1 - 5.5	5,370	3,580	1,790
5.6 - 6.0	3,580	1,790	895
6.1 - 6.5	1,790	1,790	0

Liming methods

1. Broadcasting / spreading at pond surface
2. Soil incorporation
3. Pump system – for hydrated lime
4. Platform spreading
5. Piling along shallow water edges of ponds and distributed by wind action

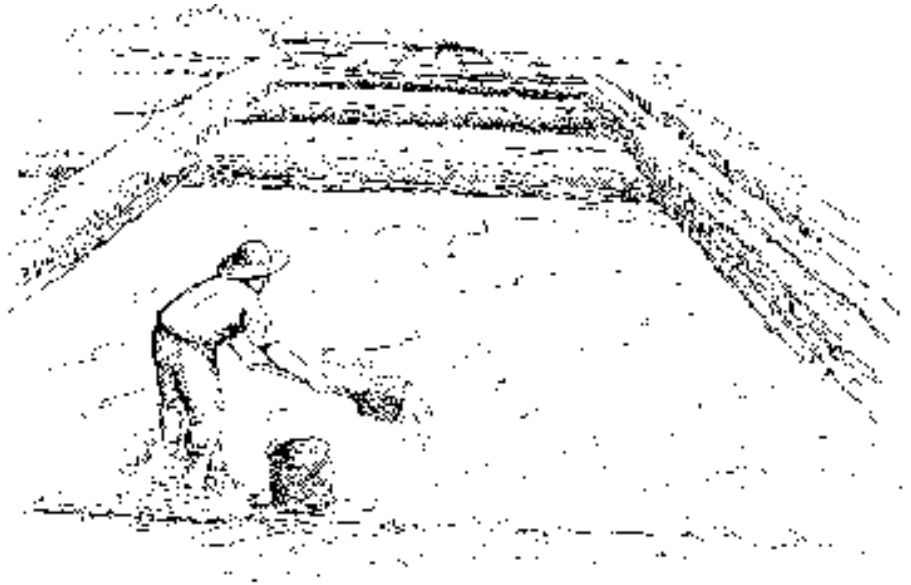

Effects of liming

Desirable effects

- High pH in mud and water stimulates microbial activity and rates of organic matter and nutrient recycling increase.
- Total alkalinity increases after liming because of greater concentration of bicarbonate, carbonate and hydroxide. An increase in total alkalinity, caused mostly by bicarbonate, results in increased concentration of CO₂ which is available for plant use.
- Fish food organisms increase.
- Production of benthic organisms increases.

In ponds with low concentrations of organic matter, the addition of readily decomposable organic matter during the liming application will hasten the dissolution of liming materials and the stabilization of water quality. The precipitation of colloidal materials in the water (following liming) may produce turbidity and

encourage the growth of underwater weeds.

Undesirable effects

- The immediate insolubility of descending lime may cause phosphorous to react with sinking lime. As a result, P is lost from the solution.
- Appreciable levels of CO₂ cannot exist in the water when pH rises.

Turbidity

Turbidity is a term that refers to the suspended dirt and other particles in water. Two sources of water turbidity are clay particles and plankton. Clay turbidity (abiotic) usually imparts brown color into the water while plankton turbidity (biotic) gives green/yellow green/brownish/yellow green color.

I Clay turbidity

Clay turbidity may come from surface runoff and the disturbance of sediments by bottom-feeding fishes. This type of turbidity can be a problem, especially in shallow ponds. The dirt and particles prevent sunlight from reaching the plankton limiting their capacity to produce oxygen. Moreover, clay particles can block fish gills, hampering respiration.

I Measures to control clay turbidity

Bales of hay may be scattered to clear up the water surface. The hay will help settle the mud particles. They can be removed easily from the pond edges. However, the method should not be used in hot weather because the hay will decay very quickly and will begin to use up oxygen in water. This method applies only to small ponds.

Organic manure at the rate of 2,440 kg/ha can also be used to control clay turbidity.

Plankton turbidity as an index of natural food productivity of the pond

Plankton turbidity is measured using a device called **Secchi disc**. When the disc goes into the water, it will sink straight down and disappear from sight at some depth. If the disc disappears at 30 cm depth, the pond contains enough natural food (mainly phytoplankton). Secchi disc visibility (SDV) depth of more than 30 cm is an indicator that there is not enough natural food and that the pond needs fertilization.

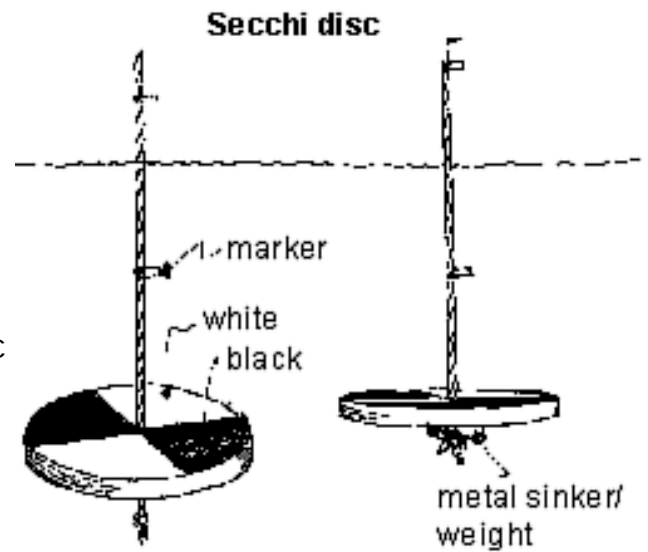

Productive tilapia ponds usually has a SDV depth between 10 to 30 cm. If SDV depth is less than 10 cm, this means that there is too much phytoplankton in the pond and there is a good chance of a die-off that may lead to DO depletion.

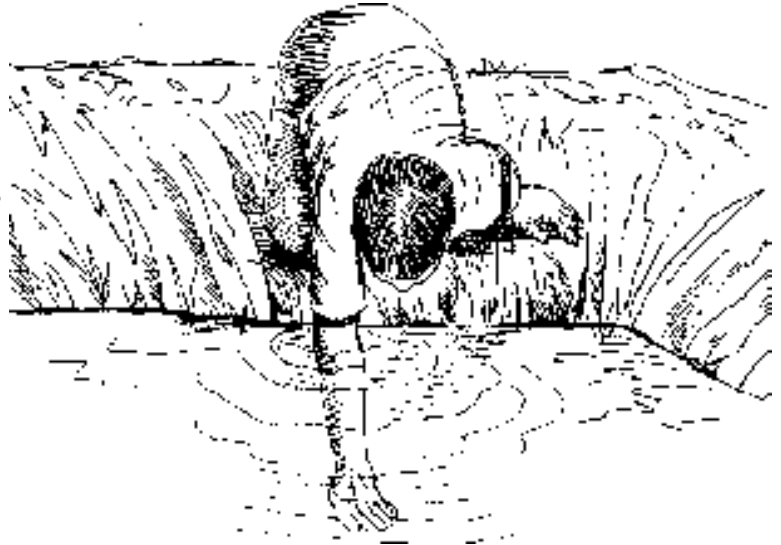

Turbidity can also be measured without a disc, but this requires experience. The farmer stands in the pond and sticks his arm under the water. If his hand disappears then the water is not too turbid. If the arm disappears before the water reaches the elbow, the water is either turbid or very productive. If the entire arm -- from hand to shoulder -- can be seen, then the water is not too turbid nor it is very productive in phytoplankton. High biotic turbidity (phytoplankton) is an indication of very fertile water that is highly conducive to DO depletion due to high phytoplankton respiration rates and die-off.

Poor dissolved oxygen

Once the DO drops to a dangerously low level, fish show signs of distress. When fish are seen gasping for air at the surface of the water, particularly in the morning, it is an indication of low DO concentration in the pond.

One of the techniques to prevent DO depletion is by aeration or circulation of pond water. By employing aeration in intensive fish culture, production can be markedly increased. The economics, however, of employing aeration in fishponds should be

considered. Some of the emergency techniques are flushing and mechanical aeration.

Gas toxicity (Nitrogen and H

2S)

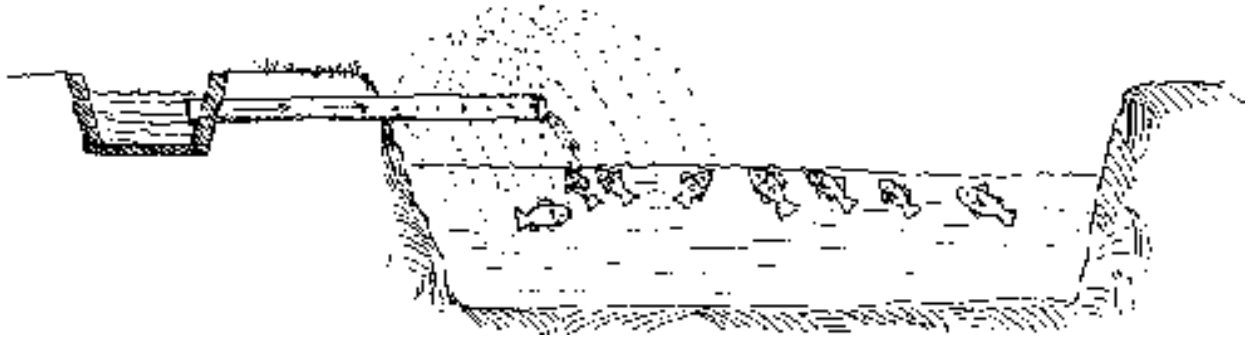

Aeration of water tends to dissipate toxic gases from the water into the atmosphere. Another management technique is to allow new water to flow into the pond in order to dilute the "old" water containing the toxic gases.

Prepared by:
Arsenia G. Cagauan