

INSULATED FISH BOXES

Types, Specifications
and Usage

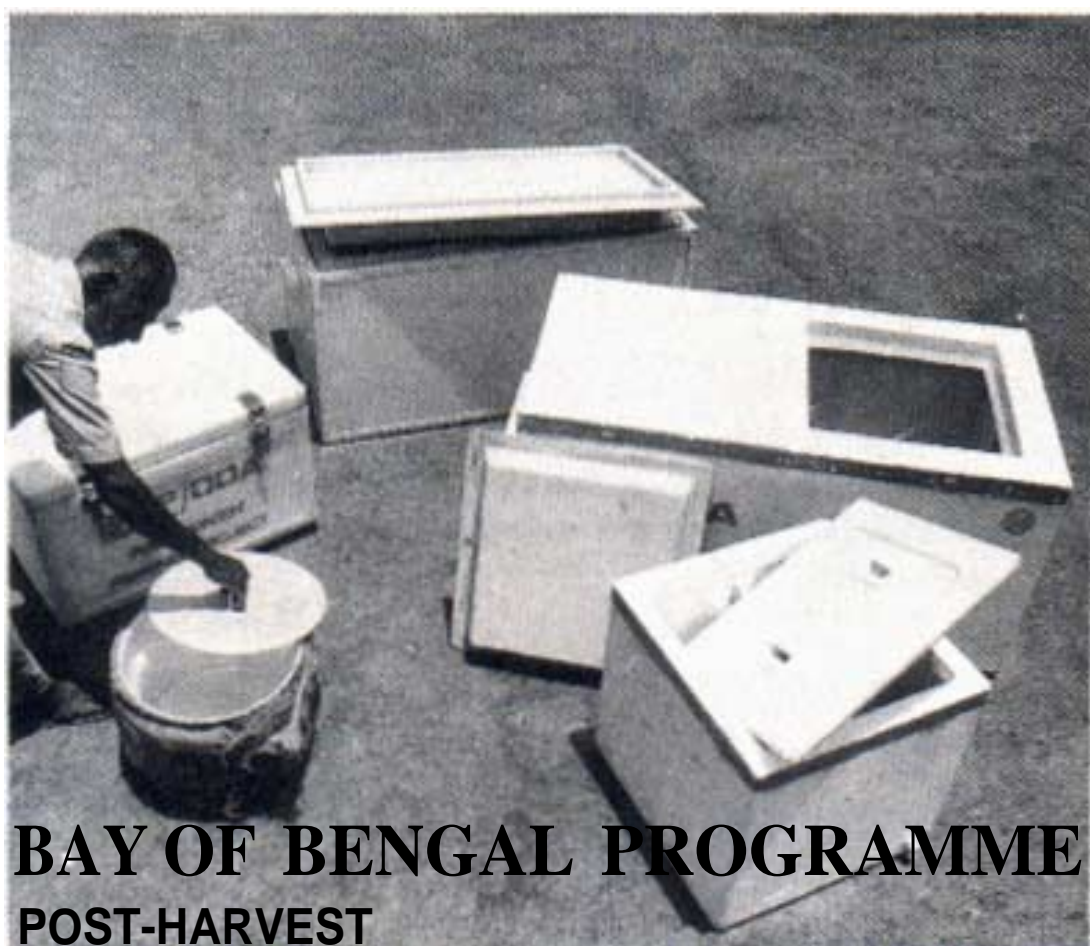

**BAY OF BENGAL PROGRAMME
POST-HARVEST
FISHERIES
PROJECT**

Overseas Development Administration

FISH BOXES

INTRODUCTION

Fish stored with ice in an insulated box will keep fresh longer. The insulated box will also help to reduce ice melting. Both these facts can help to improve fish quality and increase users' incomes.

This booklet discusses and describes various designs of insulated boxes and explains how these may be obtained either through purchasing from a local supplier or Through simple self-construction using low-cost and readily available raw materials.

There are various methods of carrying and storing fish both on the fishing craft at sea and on shore. Many of these methods utilize some form of container. Containers help to reduce damage to the fish during handling and allow more efficient marketing. Typical examples of containers are bamboo and palmyrah baskets, wooden crates, pots and buckets:



In most cases, economic advantages are available if ice is used to chill the fish as soon as possible after catching ideally on the fishing craft itself, or immediately after landing. Ice will slow down fish spoiling and help the fish command the best price in the market. Ice can be used most effectively in combination with an insulated box. Insulated boxes offer the following advantages over uninsulated containers:

- * **Less ice required to chill fish**
- * **Less ice required to keep fish cold**

This is because the warmth from the outside cannot penetrate the insulation and wastefully melt the ice, as happens in an ordinary container:

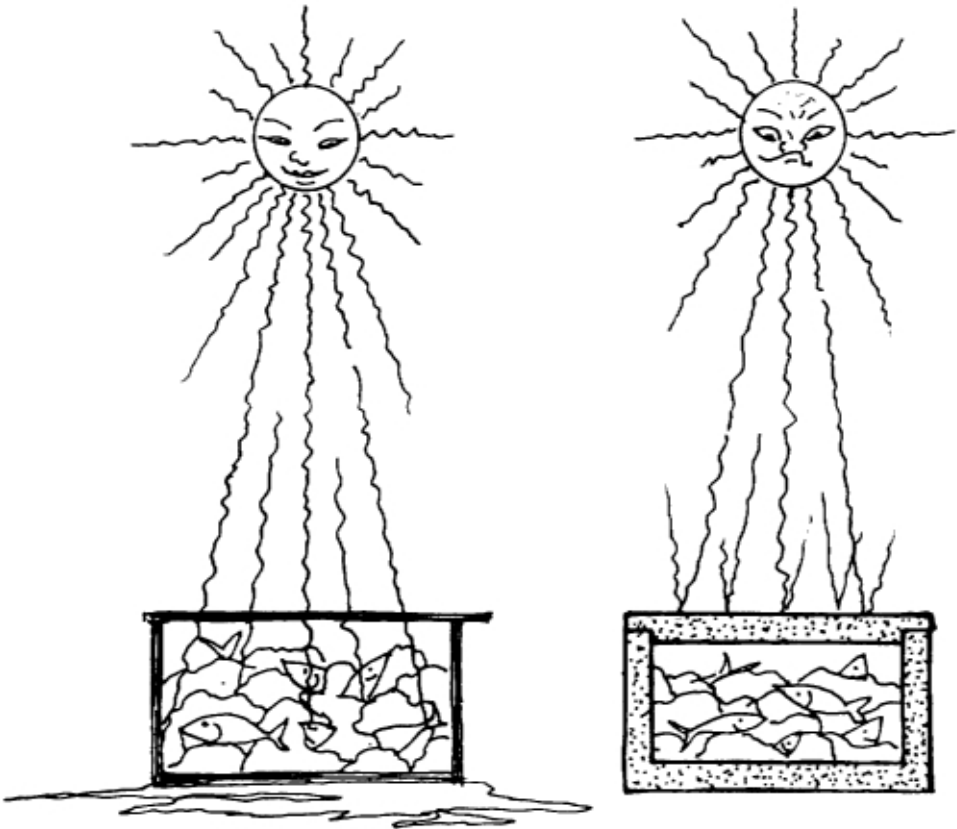

The net result is that the cost of keeping the fish fresh is much less.

The disadvantage of insulated boxes over uninsulated boxes is their higher cost.

However, by adapting their design to suit a specific requirement there may be considerable economic benefits available to the user. Some ideas on effective designs are given in this leaflet.

HOW TO MAKE INSULATED FISH BOXES

To make insulated boxes, an insulating material is best packed between two layers of strong, waterproof, non-absorbent board. Suitable materials for the insulating layer include the following:

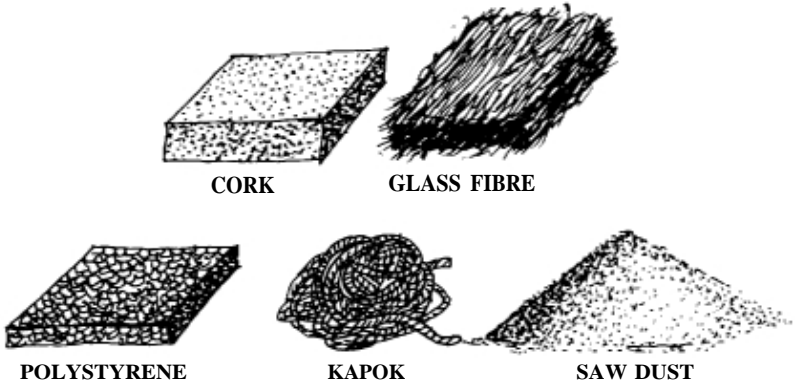

These types of insulating materials stop heat passing through and, to be effective, they should be kept as dry as possible:

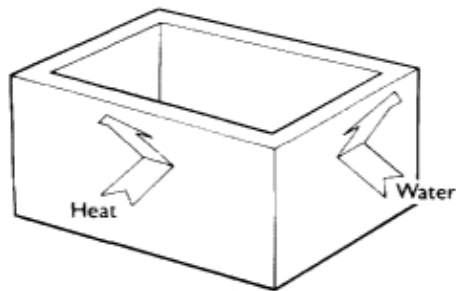

Some ideas for making insulated boxes are given on the next few pages.

MAKING THE MOST OF WHAT YOU HAVE AT HAND

1. **Simple insulated containers and boxes** can be made by wrapping gunny or any lightweight, low—cost material around a water—tight container, such as an aluminum bucket or fish container, and keeping this dry with a plastic bag tied around the outside.

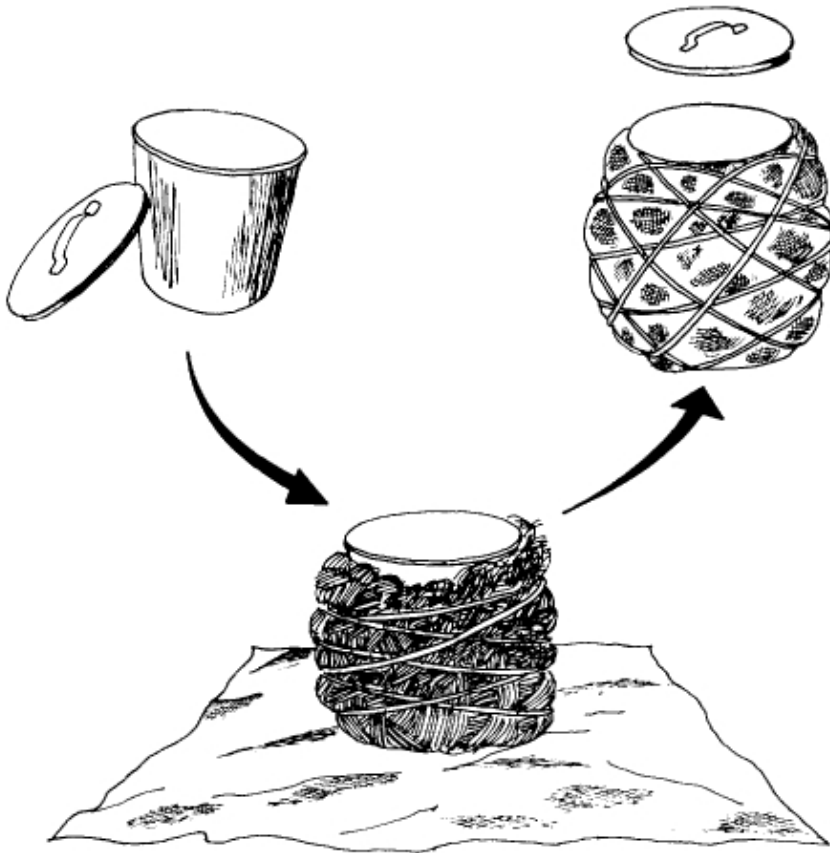

The container should have a tight fitting lid to stop warm air melting the ice **too** quickly.

BOBP tests show that ice stored in this type of container will last twice as long compared with an uninsulated container.

Contd.... Page 8

WOODEN CONSTRUCT

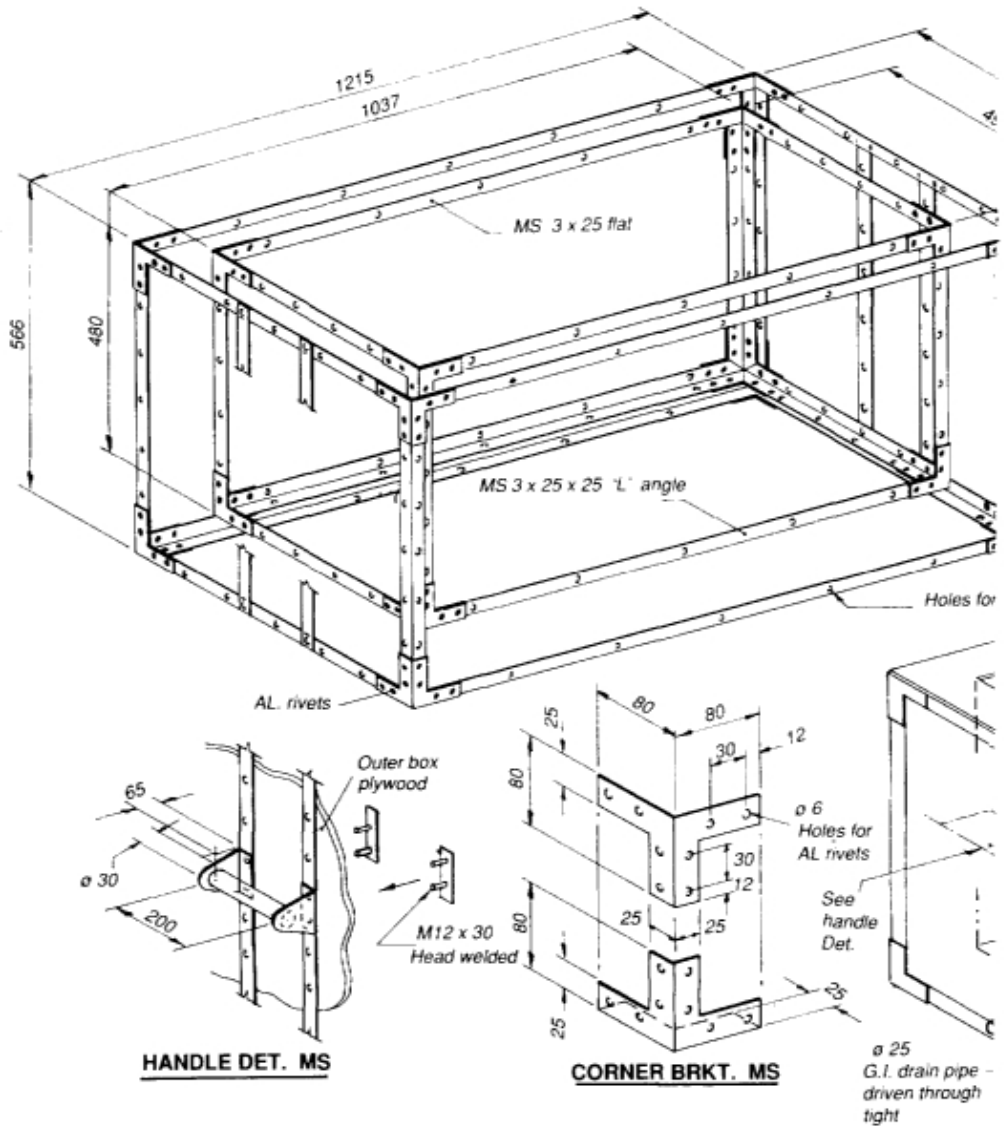

ICE BOX ION DETAIL

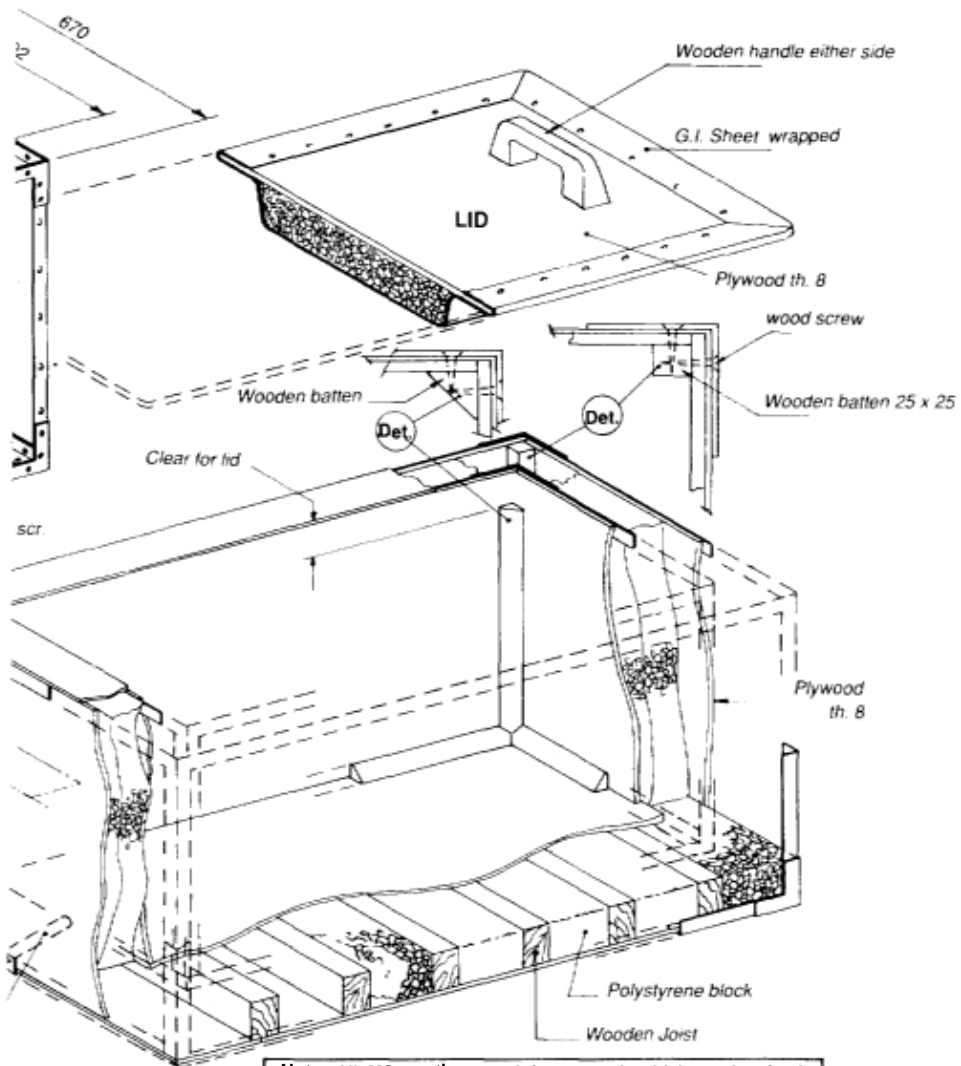

Note: All MS sections and fastners should be galvanized.
Wooden box should be finished with metal putty and paint. A GRP layer is preferred for inside.
All dimensions in mm.

2. A simple bamboo or palmyrah root basket can even be used by lining it with leaves, plastic, coconut fibre or palmyrah leaf matting:



Leaves & coconut fibre



Palmyrah matting

These baskets will need to be covered with lids made of wood, tin or gunny. These should be thick and light. The leaves, coconut fibre, and matting must be replaced after each time the basket is used.

REMEMBER: The insulation material should be kept as dry and as thick as possible.

MAKING A MORE COMPLEX BOX

A drawing is enclosed (on pages 6 & 7) of a sturdy, wooden box of approximately 170 kg capacity which any skilled carpenter can make.

The suggested specifications are as follows:

Marine plywood thickness :	8 mm
Inner dimensions :	L 1049 mm; W 488 mm; H 467 mm
Outer dimensions :	L 1215 mm; W 670 mm; H 550 mm
Insulation :	50 mm Thermocole (EPS) sheets
Thermal efficiency test result:	0.496 Cals/hr/m ² /°C(CIFT 1992)

EXISTING MANUFACTURER: Jacksons Furniture
127 Sterling Road
Nungambakkam
Madras - 600034

(Guide Price : Rs. 4,250/-)

PURCHASING A PLASTIC BOX

Glass reinforced plastic (or G R P)

is a very strong and waterproof material that is ideal for use in making insulated fish boxes. Boxes made from this material have a GRP inner and outer lining (3 mm thick) laminated directly on to polyurethane foam. In some cases, the foam is "*in situ injected*" into the pre-formed GRP structure. An insulated lid drops into a hole in the box, A drainage hole is fitted in a bottom corner and removable wooden partition planks can be provided

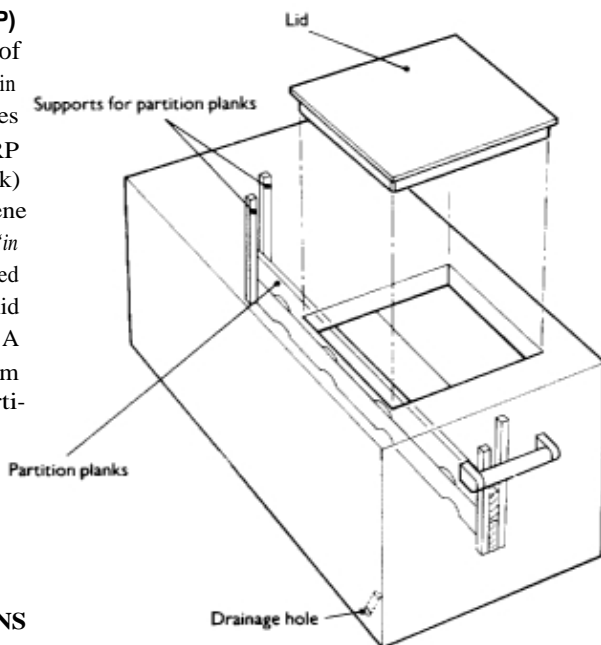

AVAILABLE SPECIFICATIONS

1. 200 kg capacity GRP Box

Inner dimensions:	L 1150 mm; W 550 mm; H 450 mm
Outer dimensions:	L 1300 mm; W 700 mm; H 600mm
Insulation:	70 mm polyurethane sheets, or polyurethane foam injected.
Thermal efficiency:	Not tested

SUGGESTED MANUFACTURERS:

1. Andhra Pradesh Fisheries Corporation
Boat Building Yard.
Kakinada - 533002,
2. Ayyappa Boat Builders
45-6-2 Jagganaikpur, Kakinada - 533002.
3. Atlantic Fibro Plastics
B-47, Electronic Complex. Kushaiguda
Hyderabad - 500762

(Guide Price : Rs, 5,700/-)

2. 65 kg capacity GRP Box

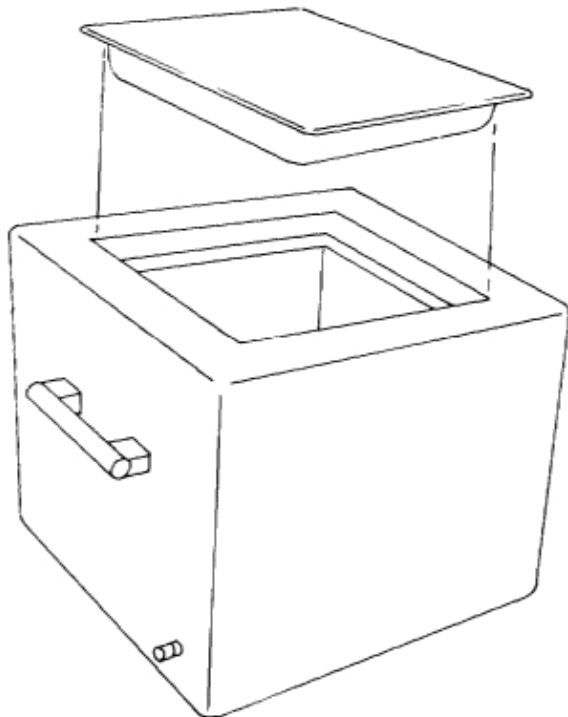

Outer dimensions: L 550 mm; W 550 mm; H 550 mm

Inner dimensions: L 450 mm; W 450 mm; H 450 mm

Insulation : 50 mm polyurethane foam injected,

Thermal efficiency test result: 0.423 Cal/hr/m²/°C(CIFT 1992)

SUGGESTED MANUFACTURER:

Atlantic Fibro Plastics
B-47, Electronic Complex
Kushaiguda
Hyderabad - 500762

(Guide Price : Rs.2,700/)

High density polyethylene (HDPE) is another very strong material that is ideal for making insulated boxes. It is slightly cheaper than GRP, especially in the smaller size ranges.

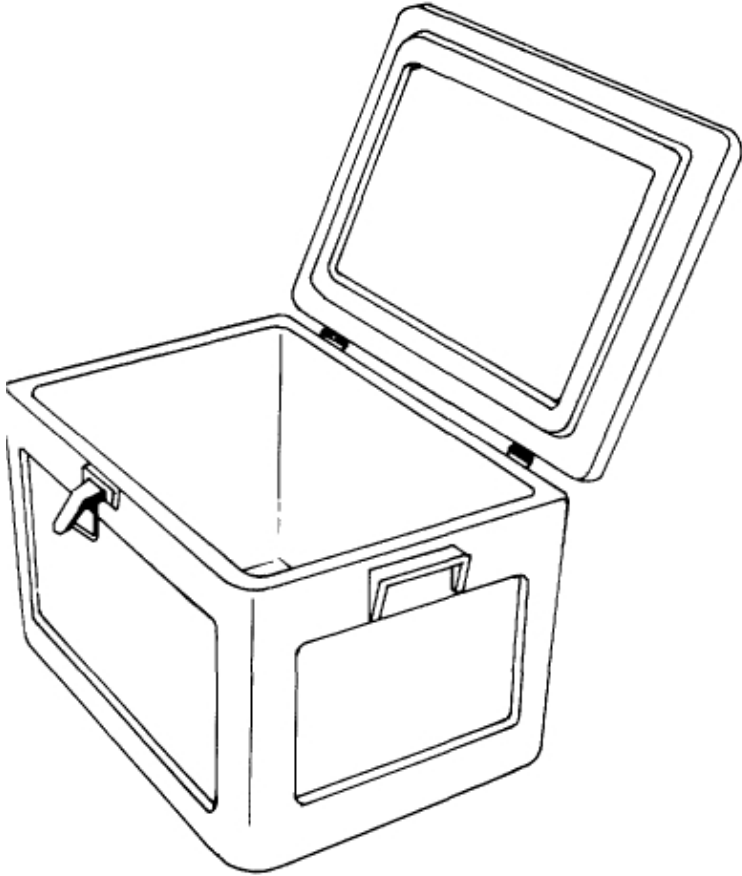

The following options are available:

100 l capacity HDPE Box (“Sintex” type)

Inner dimensions: L 670 mm; W 445 mm; H 340 mm

Outer dimensions: L 780 mm; W 540 mm; H 410mm

Insulation: 40mm polyurethane foam injected

Thermal efficiency test result: 0.420 Cals/hr/m²/°C(CIFT 1992)

Other sizes available: 20, 30, 40, 50,65,75, 125, 150, 225,325 litres.

EXISTING DEALER:

Span & Company Pvt. Ltd.
First Floor, 35 Sembudoss Street
Madras -600001.

(Guide Price (100l box) : Rs. 3,000/-)

CHECKLIST

Before you buy or make a box, check the following:

- Is size of box suitable for size of fish?
- Is the box light enough to lift when full, so that it can be carried easily?
- Is the box easy to clean?
- Is there a drain hole at the bottom?
- Is the insulation thick enough and well protected from getting wet?

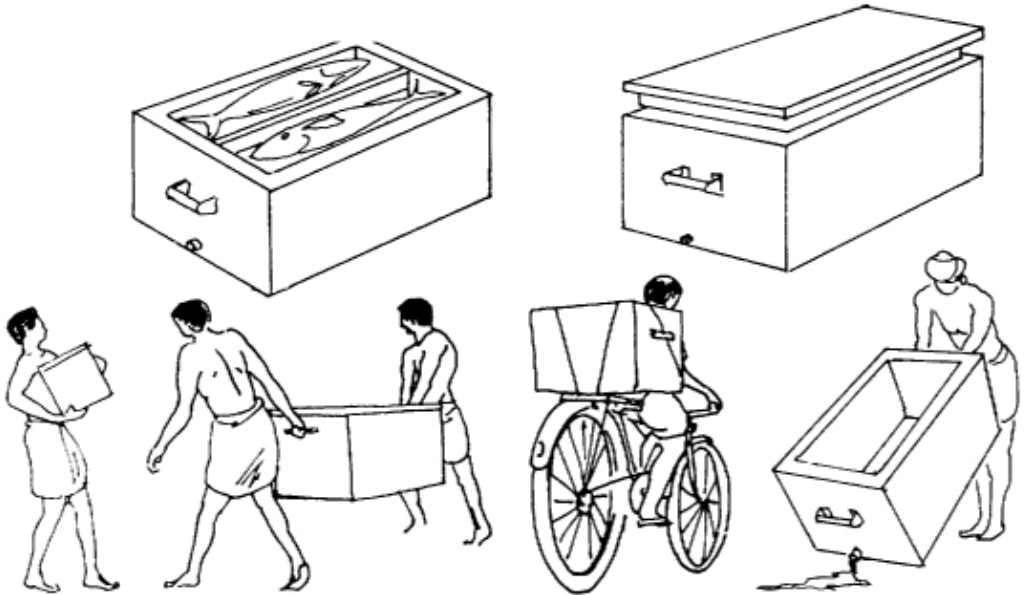

CONCLUSION

The advantages of insulated containers and boxes are:

- LESS ICE NEEDED**
- ICE LASTS LONGER**
- FISH STAYS FRESH FOR LONG TIME**
- FRESH FISH GETS BETTER PRICE**
- FISHERMEN AND TRADER EARN MORE**
- FISHERMEN AND TRADERS HAPPIER!**

GOOD FISH



GOOD FORTUNE

For further details contact manufacturers direct or local Assistant Director of Fisheries. or
BAY OF BENGAL PROGRAMME. / ODA. 9, St. Marys Road, Abhiramapuram. Madras . 600 018 India
Telephone No.: 836294/836096 Telex : 41 -83 11 BOBP. Fax: 836102